



Part # 12120210 - 1979-1989 Mustang Level 2 CoilOver System

Recommended Tools

Front Components:

12123110 Front CoilOver Strut Instructions

Rear Components:

12125899 Rear Lower StrongArms

12126699 Rear Upper StrongArms

12126110 Rear Coilover Instructions

Miscellaneous Components:

85000000 Spanner Wrench

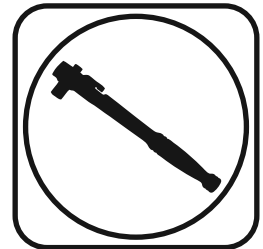

1979-1989 Mustang Level 2 Coilover Installation Instructions

Table of contents

Pages 2-7..... Front CoilOvers

Pages 8-9..... Rear Lower StrongArms

Pages 10-11..... Rear Upper StrongArms

Pages 12-20..... Rear CoilOvers





Part # 12123110 -1979-1989 Mustang



Recommended Tools

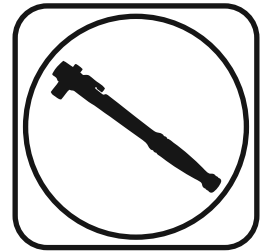

1979-1989 Mustang Front CoilOver Strut Installation Instructions

Table of contents

- Page 3..... Included components
- Page 4..... Disassembly and Getting Started
- Page 5..... Upper Mount Assembly
- Page 6..... Final Assembly and Spring Adjustment & Preload
- Page 7..... Spring Adjustment and Strut Adjustment





Included ComponentsIn the box

Item #	Part #	Description	QTY
1	986-10-055	Strut Cartridge	2
2	90002470	Bearing Retaining Mount	2
3	70012092	Upper Caster Plate-Driver(Shown)	1
3	70012094	Upper Caster Plate-Pass	1
4	90002478	Lower Caster Plate-Driver (Shown)	1
4	90002479	Lower Caster Plate-Pass	1
5	70011289	Strut Extrusion	2
6	90002368	Thrust Bearing Adapter	2
7	70010987	Thrust Bearing	2
8	70010988	Thrust Bearing Washer	4
9	90001042	Upper Mount Bearing	2
10	90000805	Bearing Snap Ring	2
11	99562003	9/16"-18 Nylok Nut	2
12	803-00-199	Coil Spring Retaining Kit	2
13	59100200	CoilSpring	2
14	70010828	Delrin Coil Spring Washers	4
15	90000801	Eccentric Bolt	2
16	038-01-035	Strut Retaining Ring	2
17	99371042	3/8"-16 x 1" SHCS	6
18	70012031	Spindle Spacer-.120" Thick	4
19	70012032	Spindle Spacer-.097" Thick	4
20	99371029	3/8"-16 x 3/4" BHSC	6
21	99373010	3/8" Split Lock Washer	6
22	99251012	1/4"-20 x 1 1/4" SHCS	8
23	99253009	1/4" Flat Washer	8
24	99253007	1/4" Split Lock Washer	8
25	90002365	Coil Spring ro Bearing Adapter	2
	90002263	Tube Red Loctite	1
	90002276	Tube Anti-sieze	1

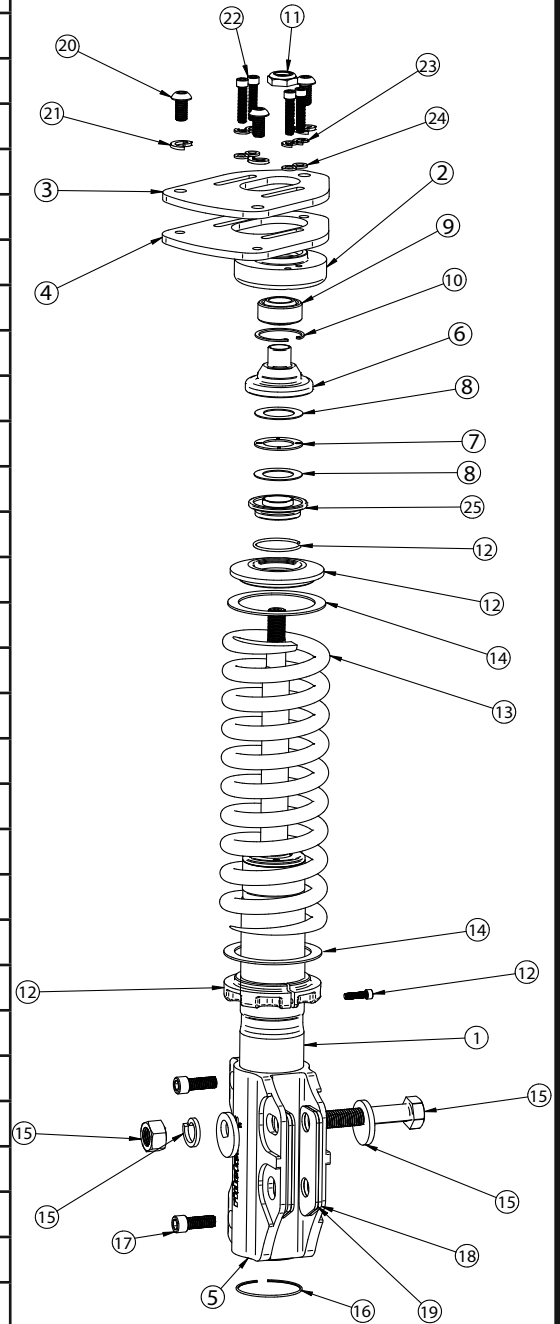



Disassembly

1. This kit will replace the OEM Strut, Coil Spring, and Upper Strut Mount. These items will need to be removed from the car. It will be necessary to disconnect the Swaybar from the Lower Control Arm and remove the Disc Brake Caliper from the spindle, **DO NOT LET THE CALIPER HANG BY THE BRAKE LINE.** Refer to the factory service manual for disassembly procedure...
2. Support the front hub and control arm assembly and remove the (2) struts bolts(retain hardware) that attach the strut to the spindle.
3. Remove the (3) nuts holding the upper strut mount to the car body. **DO NOT REMOVE THE CENTER NUT.**
4. Remove strut assembly from the car.

Getting Started

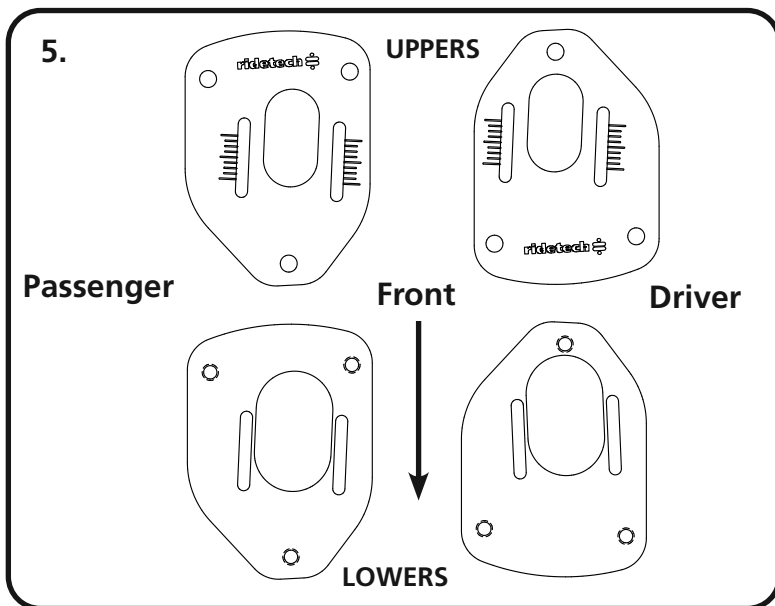

5. The upper strut mount provided in this kit has been designed to provide the ability to get more caster adjustment than the OEM setup. Camber adjustment is done at the spindle mount. The Upper Caster Plate consists of 2 Plates per side and they are specific to each location. The Steel Plate is installed on the bottom side of the Strut Tower and the Aluminum Plate is installed on the top of the strut tower. The Aluminum Upper Plate is installed with the Ridetech Logo readable from the front of the car. If the logo is upside down when standing at the front of the car, the plate is installed on the incorrect side.

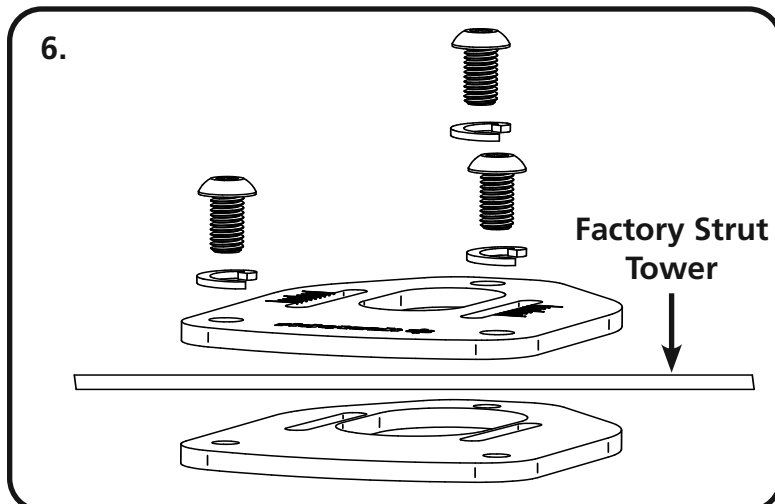

6. Use Illustration 6 to help you determine the correct position and orientation of the Caster Plates. Position the Steel Plate on the bottom side of the Factory Strut Tower. Lay the Aluminum Upper Plate on top of the Strut Tower aligning the 3 holes with the holes in the Tower. Apply Red Loctite to (3) 3/8" x 3/4" Button Head Bolts. Install a 3/8" Lock Washer on each Bolt and thread one in each hole of the Upper & Plate. Tighten all 3 bolts on each side. The slots in the Upper & Lower Plates should line up.



Upper Mount Assembly

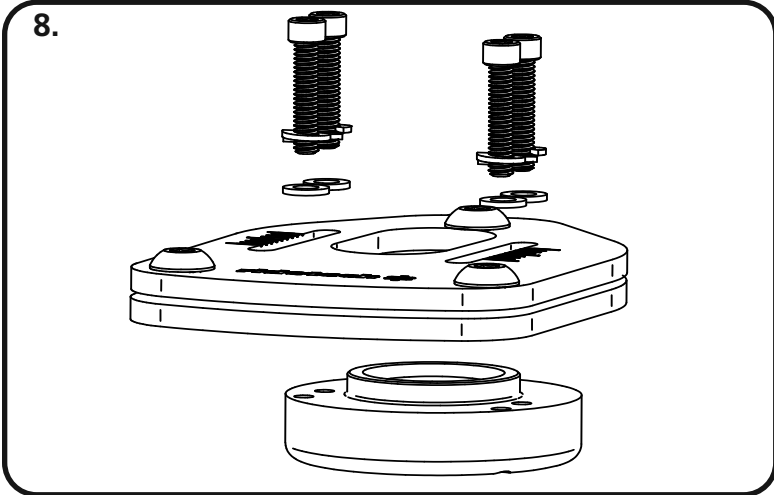

8. Attach the Bearing Housing to the Caster Plate Assembly. The Housing is positioned with the 4 threaded bolt holes to the front of the car lining 2 holes up with each slot. Insert the housing up from the bottom. Apply Antiseize to the threads of each of the (4) 1/4" x 1 1/4" Socket Head Bolts. Install a 1/4" Lock Washer and Flat Washer on each bolt. The bolts will be inserted through the caster plate with 2 bolts in each slot threading into the Bearing Housing.

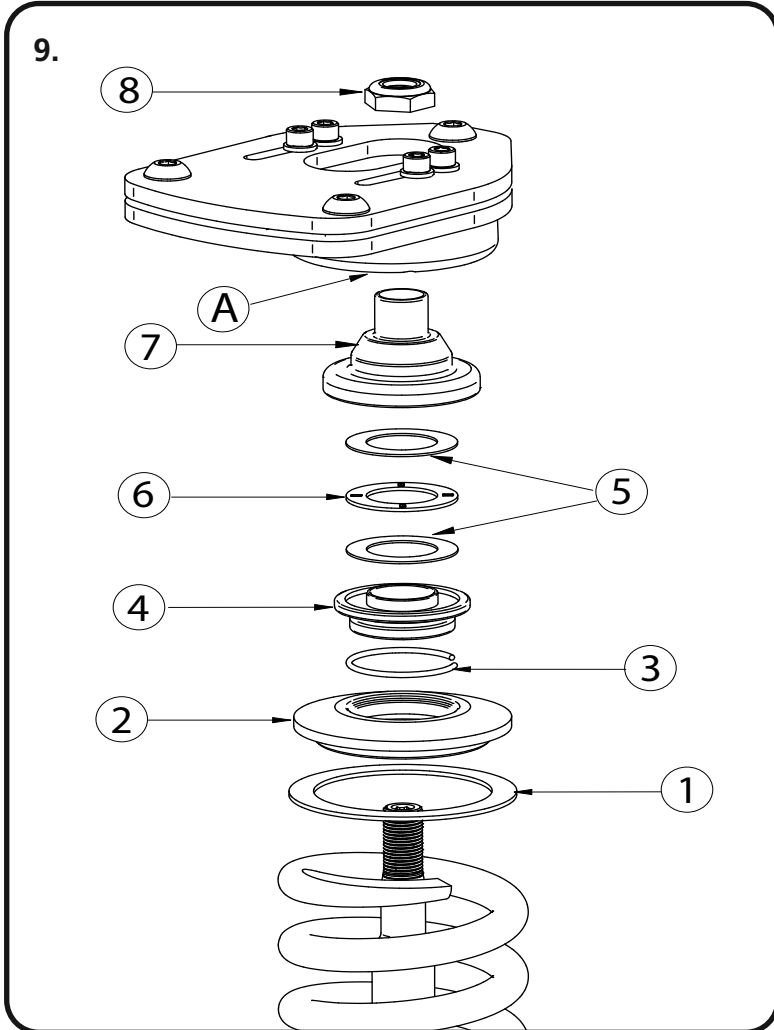

9. Remove the Adjuster Knob from the Strut shaft for assembly. With the CoilSpring installed on the Strut, bolt the strut assembly into the upper mount (A), see diagram 11 for assembly order.

- 1. Delrin CoilSpring Washer
- 2. Upper CoilSpring Cap
- 3. CoilSpring Cap Retaining Ring (Installed On #4 CoilSpring to Bearing Adapter)
- 4. CoilSpring to Bearing Adapter
- 5. Torrington Bearing Races
- 6. Torrington Bearing
- 7. Bearing Adapter (Small Diameter Up)
- 8. 9/16" Locknut

Assemble components and install into upper mount tightening upper nut. Reinstall upper adjustment knob.



Assembly

10.

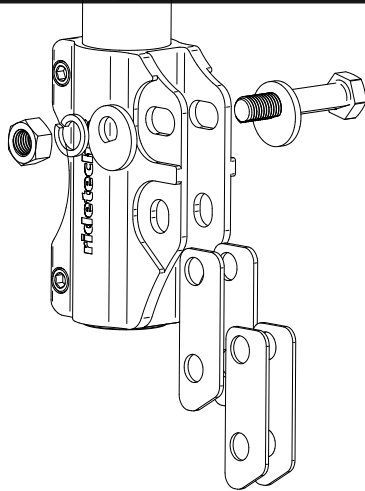

10. Due to various thickness of the spindles, the kit comes with shims for the spindle. It may necessary to run multiple shims of some. If multiple shims are required, install (1) Thick and (1) Thin on each side of the spindle. The lower Strut mounting holes reuses the OEM Bolt. The upper Slotted holes use the 16mm Eccentric Bolt provided in the kit. This Eccentric Bolt is used for camber adjustment.

NOTE: Torque Strut Mounting Bolts to 135 ftlbs

11. Repeat previous steps on Passenger side.
12. After both sides are installed, reattached the Sway Bar Linkage and Reinstall the Brake Caliper.
13. It will be necessary to have the car aligned after installing the Ridetech Strut Setup.

Spring Adjustment and Preload

Ride Height

We have designed most cars to have a ride height of about 2" lower than factory. To achieve the best ride quality & handling, the shock absorber needs to be at 40-60% overall travel when the car is at ride height. This will ensure that the shock will not bottom out or top out over even the largest bumps. Measuring the shock can be difficult, especially on some front suspensions. Measuring overall wheel travel is just as effective and can be much easier. Most cars will have 4-6" of overall wheel travel. One easy way to determine where you are at in wheel travel is to take a measurement from the fender lip (center of the wheel) to the ground. Then lift the car by the frame until the wheel is just touching the ground, re-measure. This will indicate how far you are from full extension of the shock. A minimum of 1.5" of extension travel (at the wheel) is needed to ensure that the shock does not top out. If you are more than 3" from full extension of the shock then you are in danger of bottoming out the shock absorber.



Spring Adjustment and Preload continued.....

Adjusting Spring Height

When assembling the CoilOver, screw the spring retainer tight up to the spring (0 preload). After entire weight of car is on the wheels, jounce the suspension and roll the car forward and backward to alleviate suspension bind.

- If the car is too high w/ 0 preload then a smaller rate spring is required. Although threading the spring retainer down would lower the car, this could allow the spring to fall out of its seat when lifting the car by the frame.
- If the car is too low w/ 0 preload, then preload can then be added by threading the spring retainer up to achieve ride height. On 2.6" - 4" stroke shocks, up to 1.5" of preload is acceptable. On 5-7" stroke shocks, up to 2.5" of preload is acceptable. If more preload is needed to achieve ride height a stiffer spring rate is required. Too much preload may lead to coil bind, causing ride quality to suffer.

Strut Adjustment

Strut Adjustment 101- Single Adjustable

Rebound Adjustment:

How to adjust your new struts.

The rebound adjustment knob is located on the top of the Strut protruding through the upper mount.

You must first begin at the ZERO setting, then set the shock to a soft setting of 20.



-Begin with the Strut adjusted to the ZERO rebound position (full stiff). Do this by rotating the rebound adjuster knob clockwise until it stops.

-Now turn the rebound adjuster knob counter clock wise 20 clicks. This sets the shock at 20. (settings 21-24 are typically too soft for street use).

Take the vehicle for a test drive.



-If you are satisfied with the ride quality, do not do anything, you are set!

-If the ride quality is too soft increase the damping effect by rotating the rebound knob clock wise 3 clicks.

Take the vehicle for another test drive.



-If the vehicle is too soft increase the damping effect by rotating the rebound knob clock wise 3 additional clicks.

-If the vehicle is too stiff rotate the rebound adjustment knob counter clock wise 2 clicks and you are set!

Take the vehicle for another test drive and repeat the above steps until the ride quality is satisfactory.

Note:

One end of the vehicle will likely reach the desired setting before the other end. If this happens stop adjusting the satisfied end and keep adjusting the unsatisfied end until the overall ride quality is satisfactory.



Part # 12135899 - 1979-2004 Mustang Rear Lower StrongArm Kit

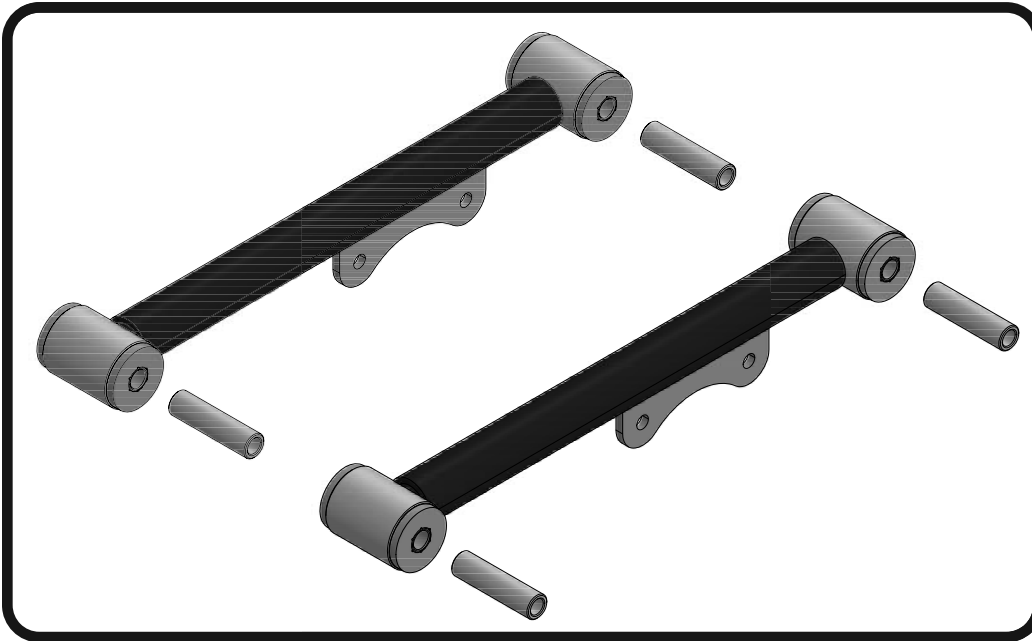

Recommended Tools



1979-2004 Mustang Rear Lower StrongArms Installation Instructions

Table of contents

Page 9..... Included Components & Installation

The kit comes with the 12mm inner sleeves installed. If your car has 14mm bolts in the lowers, you will need to switch the inner sleeves.





Included ComponentsIn the box

Item #	Part #	Description	QTY
1	90001020	BARWW17.625 Mustang Rear Lower	2
2	90001089	Poly Bushing Half	8
3	90001375	12mm Inner Sleeve - INSTALLED IN CONTROL ARMS	4
4	90000598	14mm Inner Sleeve	4

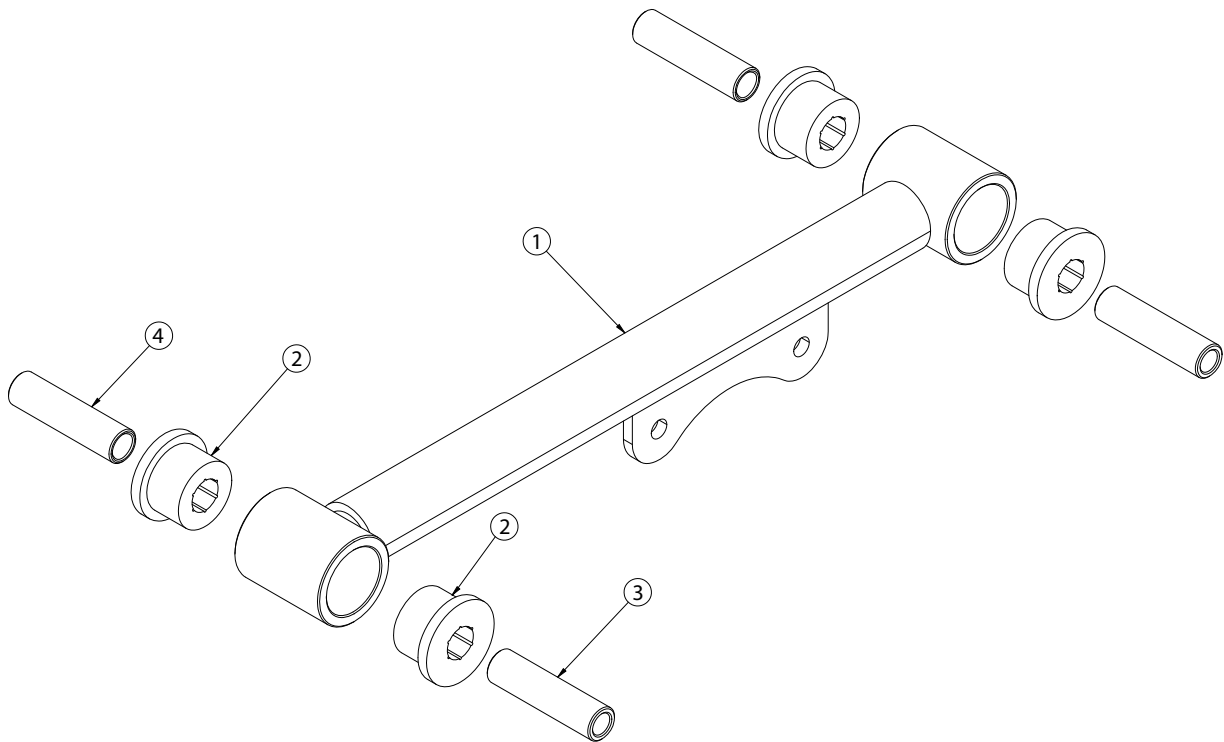

StrongArm Installation



1.

The kit comes with the 12mm inner sleeves installed. If your car has 14mm bolts in the lowers, you will need to switch the inner sleeves.

1. Remove the OEM lower, retaining the hardware. Install the NEW Lower Control Arm with the Sway Bar Mount on the bottom, an to the FRONT of the car. If you are installing Ridetech CoilOvers or ShockWaves at the same time, use the LONGER Hardware supplied with the kit for the rear lower control arm mounting. Tighten the hardware to eliminate any gaps.



Part # 12136699 - 1979-2004 Mustang Rear Upper StrongArm Kit

Recommended Tools

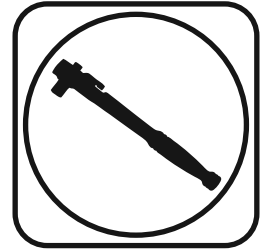

1979-2004 Mustang Rear Upper StrongArms Installation Instructions

Table of contents

Page 11..... Included Components & Installation





Included ComponentsIn the box

Part Number	Description	QTY
90001117	Upper Control Arms (set to 9.375")	2
70013364	RH R-Joint Threaded Housing End (installed in bars)	2
70014802	R-Joint Spacers	4
R-Joint Components - (Installed in bar ends)		
70013275	R-Joint Center Ball	2
70013276	R-Joint Composite Center Ball Cage	2
70013279	Retaining Ring	2
70013280	Wavo Wave Spring	2

R-JOINT SPACER INSTALLATION

Install the Spacers by inserting the SMALL side of the SPACER into the Center Pivot Ball. Push them in until they bottom out and stop.

UPPER R-JOINTS

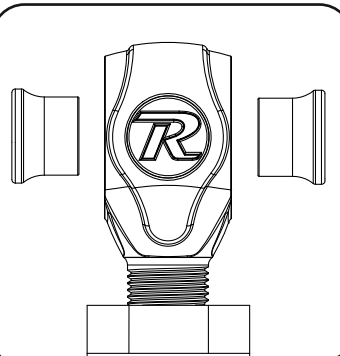

New R-Joints will be quite stiff (75-90 in/lbs breakaway torque) until they "break in" after a few miles of use. After the break in period they will move much more freely. Because the composite bearing race contains self lubricating ingredients, no additional lubrication is needed or desired. Any additional lubrication will only serve to attract more dirt and debris to the R-Joint and actually shorten its life.

StrongArm Installation



1. Install the R-Joint Spacers into the R-Joint End. Remove the OEM Upper Control Arms and replace them with the StrongArms. Tighten the hardware to eliminate any gaps.



Part # 12126110 - 1979-1993 Mustang HQ CoilOvers

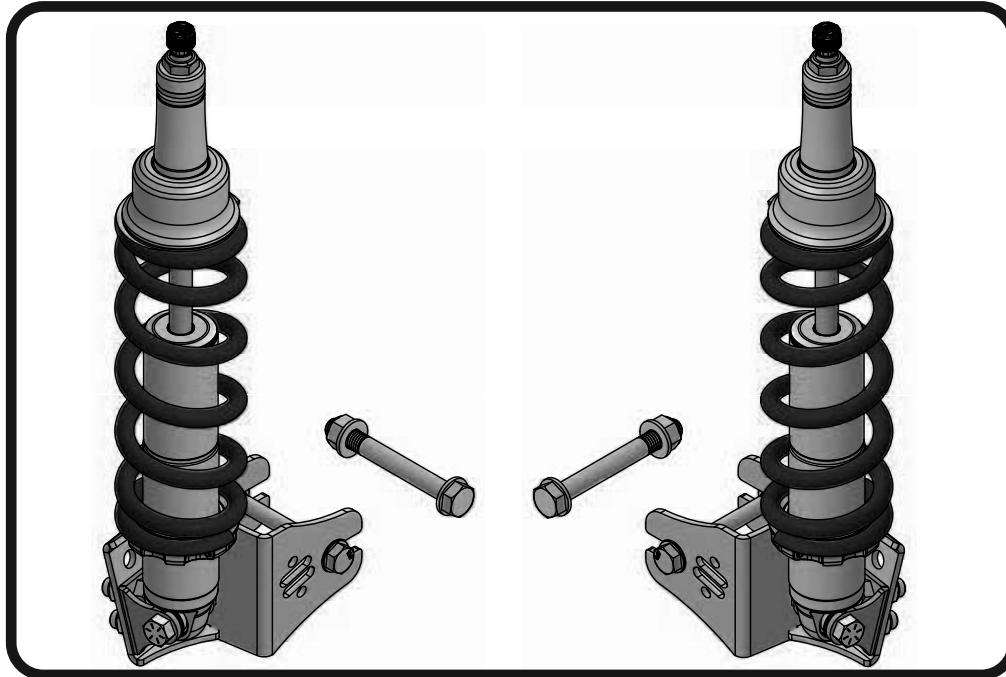

Recommended Tools



1979-1993 Mustang HQ Series Rear CoilOvers

Installation Instructions

Table of contents

Page 13-14.....	Included Components
Page 15.....	Getting Started and Disassembly
Page 16.....	Body Prep and Lower Mount Installation
Page 17.....	CoilOver Assembly
Page 18.....	CoilOver Installation
Page 19.....	CoilSpring Adjustment
Page 20.....	Shock Adjustment





Major ComponentsIn the box

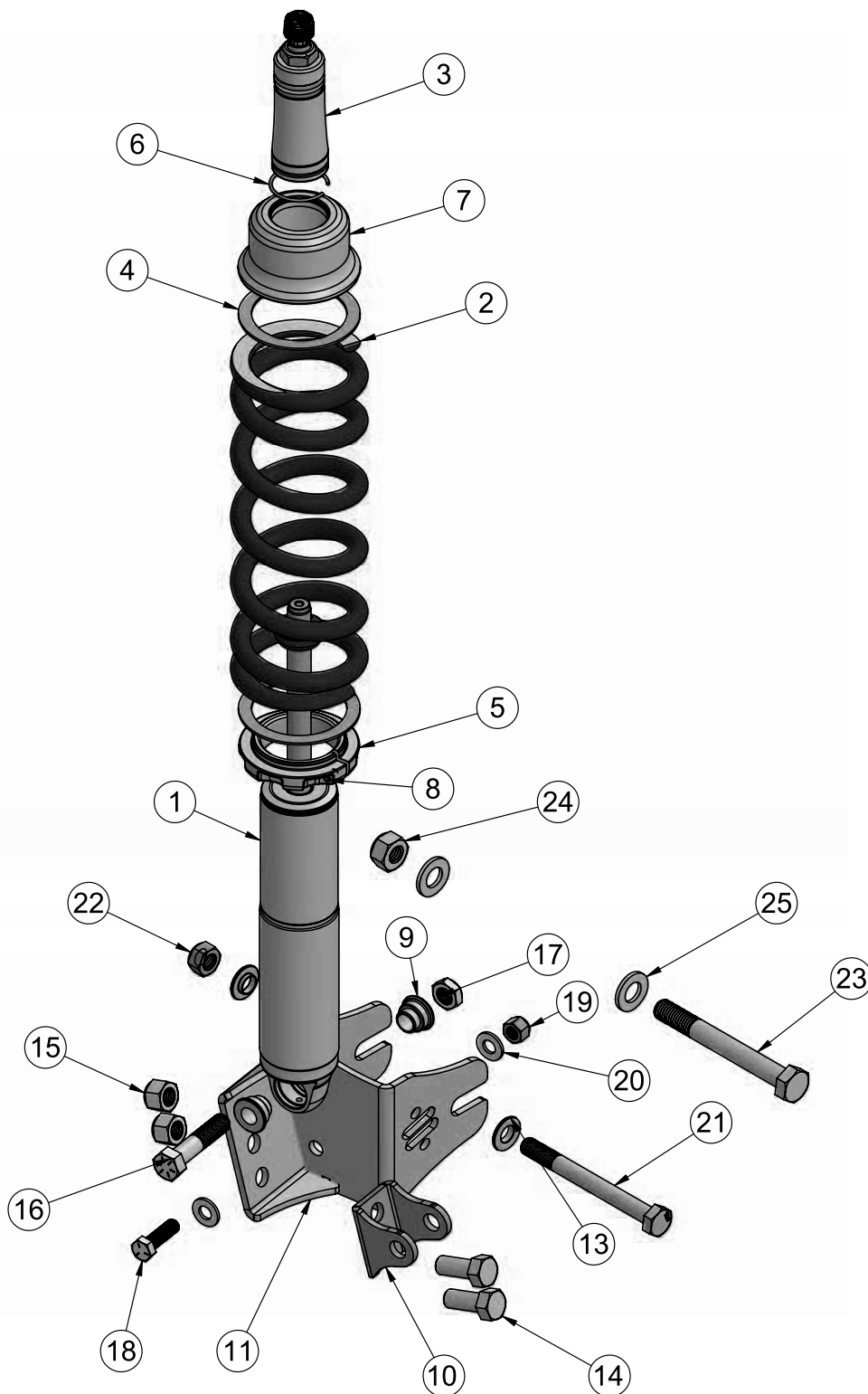



Major ComponentsIn the box

Item	Part #	Description	QTY
1	982-10-805	5.2" Stroke HQ Series Shock	2
2	59100125	CoilSpring	2
3	90002049 Kit	90009989 - 2.75" Stud Top	2
3	90002049 Kit	90002313 - 2.75" Stud Top Base	2
3	90002049 Kit	90001904 - Lower Delrin Half	2
3	90002049 Kit	90001903 - Upper Delrin Ball Half	2
3	90002049 Kit	90001902 - Upper Delrin Ball Cap	2
3	90002049 Kit	99562003 - 9/16-18" Nylok Nut	2
4	70010828	Delrin Washer	4
5	234-15-200	CoilSpring Mount Locking Ring	2
6	038-01-006-A	CoilSpring Mount Retaining Ring	2
7	90001373	CoilSpring Mount 1.5" Drop Cap	2
8	99050001	CoilSpring Mount Locking Ring Clamp Bolt	2
9	90002043	Shock Bearing Spacer - 1/2" ID	4
10	90002158	2 Hole Lower Shock Mount	2
11	90002467	Driver Lower Shock Mount-Axle Mount	1
11	90002468	Passenger Lower Shock Mount-Axle Mount (Not Shown)	1
13	90001372	14mm to 12mm T-Bushing	4
14	99501019	1/2"-13 x 1 1/4" Hex Bolt (2 Hole Mount to Axle Mount)	4
15	99502001	1/2"-13 Nylok Nut (2 Hole Mount to Axle Mount)	6
16	99501010	1/2"-20 x 2 1/4" Hex Bolt (Lower Shock to Mount)	2
17	99502003	1/2"-20 THIN Nylok Nut (Lower Shock to Mount)	2
18	99371004	3/8"-16 x 1 1/4" Hex Bolt (Lower Mount to Axle)	2
19	99372002	3/8"-16 Nylok Nut (Lower Mount to Axle)	2
20	99373003	3/8" SAE Flat Washer (Lower Mount to Axle)	4
21	99121013	M12-1.75 x 120mm Hex Bolt (Axle Mount to Axle)	2
22	99122001	M12-1.75 Nylok Nut (Axle Mount to Axle)	2
23	99141005	M14-2.0 x 120mm Hex Bolt (Axle Mount to Axle)	2
24	99142002	M14-2.0 Nylok Nut (Axle Mount to Axle)	2
25	99143001	M14 Flat Washer (Axle Mount to Axle)	4
	90001995	Bearing Snap Ring (Installed in Shock Body)	4
	90001994	5/8" ID Bearing (Installed in Shock Body)	2



Getting Started and Disassembly

Congratulations on your purchase of the Ridetech Mustang CoilOver System. This system has been designed to give your Mustang excellent handling along with a lifetime of enjoyment. The CoilOver System provides flexibility that can not be achieved with Conventional CoilSprings.

This CoilOver System is Designed to replace the factory Shock and CoilSprings.

1. The rear OEM Shocks, Pinion Snubber and Mount, CoilSpring, and Horizontal Kicker Shock will need to be removed from the Rear of the car.
2. Raise the vehicle and support it by the frame allowing the suspension to hang freely. Be sure the rear differential will be able to swing down to get the rear springs out.
3. Place a jack under the center of the rear differential and raise it up to the point the jack is touching the rear differential. Be sure that the car is high enough that you will be able to lower the jack supporting the rear differential to remove the Coilsprings.
4. The Nut will need to be removed from the top of the shock. The top of the shock is either locked in the trunk behind the side covers, or in the hatch under a plastic cover located by the wheel tub.
5. Unbolt the lower shock from the shock mounting bracket and unbolt the shock bracket from the differential.
6. Lower the jack slowly to remove the tension of the Coilspring. Pay attention to the brake line and ABS(if equipped) wire that you don't damage them when lowering the differential
7. With the springs loose, remove the from the car.
8. Remove the OEM Pinion Snubber and mount from the rear body.

To get Started refer to the page 5.

NOTE: THE LOWER CONTROL ARM BOLT SIZE CAN VARY DEPENDING ON THE YEAR OF CAR YOU ARE INSTALLING THE COILOVERS ON. WE HAVE INCLUDED 12MM & 14MM FOR THIS REASON. YOU WILL NEED TO DETERMINE THE CORRECT SIZE HARDWARE FOR YOUR INSTALLATION.



Body Prep and Lower Mount Installation

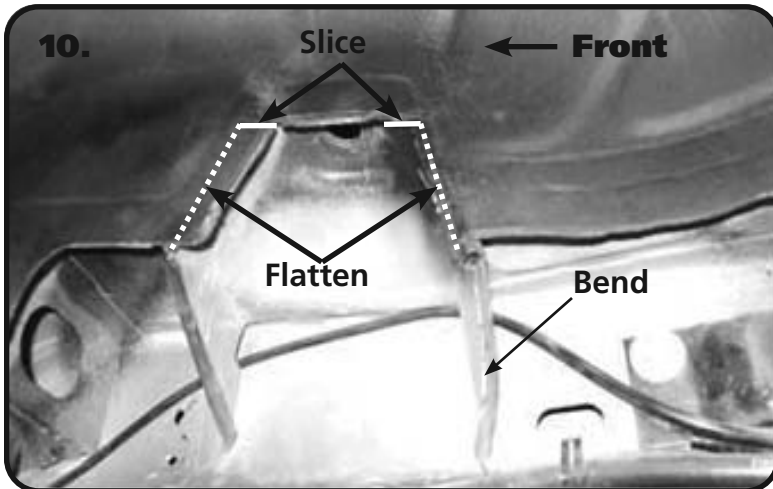

10. Illustration 10 shows the modifications that need to be done to the Shock opening for CoilOver clearance. The rear has been done in the picture to show what the end result should look like. Slice the sheet metal at the top of the opening forward and backward even with the top of the opening. With the sheet metal sliced, bend the pinch weld inward until it is flat against the front and back of the opening. Bend the rear brace back to clear the Air Spring on the Shockwave.

Repeat on both sides of the car.

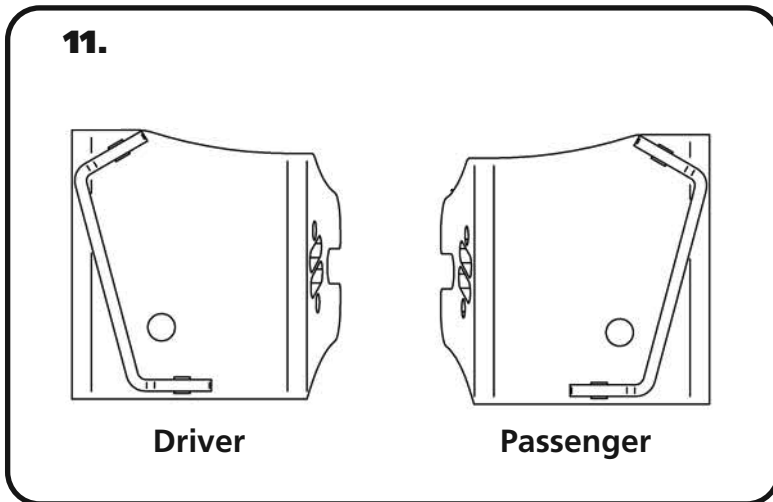

11. If you haven't done so already, remove the OEM Lower Shock Mount from the axle. If you are installing StrongArms, now is a great time to do the Lower. The size of your control arm bolts will determine the proper steps for mounting the lower shock mount. If your car has a 14mm lower control arm bolt, remove it and replace it with the M14-2.0 x 120mm bolt supplied in the kit. You will need to install a M14 flat washer on the bolt before installing it. Install the 14mm bolt/washer and install a M14 flat washer & M14-2.0 nylok nut on the bolt. Leave the bolt loose for now. If your car has a 12mm bolt, install one of the T-Bushings on the M12-1.75 x 120mm bolt with the large OD against the bolt head. Insert the 12mm bolt/t-bushing. Install a 2nd T-Bushing, with the Large OD to the nut, on the threads sticking through the axle mount, followed by a M12-1.75 nylok nut. Leave the nut loose for now.



Illustration 11 shows the New Lower Shock Mount viewed from the rear.

12. Slide the Lower Shock mount on to the Axle Mount. The Shock Mount wraps around the OEM Control Arm mount. The Slots on the side of the Mount slide on the Lower Control Arm Mounting Bolt. Install (1) 3/8-16 x 1 1/4" bolt (Threads pointing forward) through the hole in the Shock Mount and Lower Control Arm Mount. Install a 3/8" Flat Washer and 3/8" Nylok Nut on the Bolt and tighten. Tighten the Lower Control Arm Bolt.



CoilOver Assembly

13.

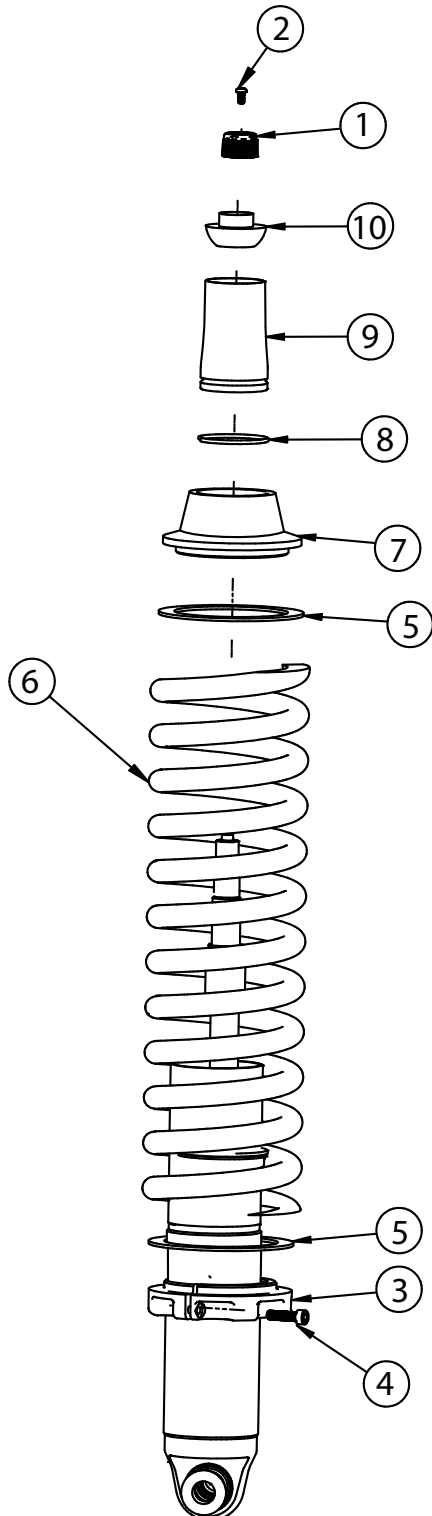

13. To Assemble the CoilOver you need to:

- a. Remove Screw (2) from center of Adjustment Knob (1) and remove Adjustment Knob.
- b. Remove Nylok Nut, Delrin Upper Cap, Delrin Upper and Lower Balls, along with the base from the CoilOver stud.
- c. Thread Adjuster Nut (3) onto the CoilOver body. Once it is threaded on the shock body, lightly thread in the locking screw (4) into the Adjuster Nut.
- d. Install a Delrin Spring Washer (5) onto the Adjuster Nut.
- e. Slide the CoilSpring (6) onto the CoilOver.
- f. Install another Delrin Spring Washer (5) on top of the CoilSpring.
- g. Install the Upper CoilSpring Plate (7) onto the CoilSpring.
- h. Install the CoilSpring Retaining Ring (8) onto the Stud Top Base (9). It fits into the groove in the base.
- i. Slide the Stud Top Base onto the shock until it bottoms out on the stud. It may be necessary to thread the Adjuster Nut down the shock body (to lower the spring) if the base will not slide all the way down onto the stud.
- j. Slide the Lower Delrin Ball (10) (it has the collar sticking up around the center hole) on to the Stud Top.

Repeat on second CoilOver.



CoilOver Installation

14.

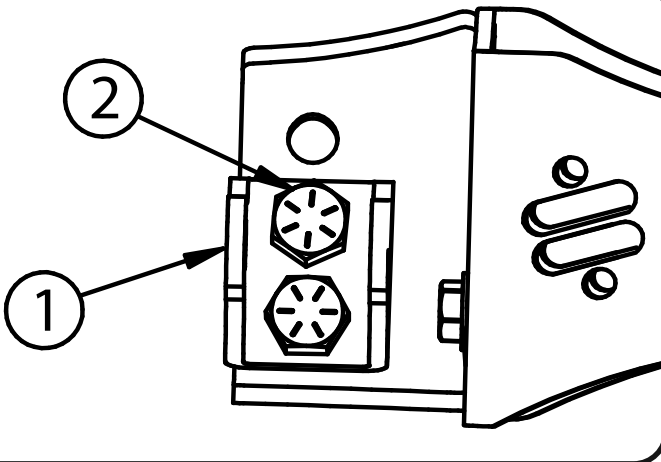

14. Attach the 2 Hole Lower Shock Mount(1) to the Main Mount using $\frac{1}{2}$ " x $1 \frac{1}{4}$ " bolts (2) with a Nylok nut on the back side. The Mount bolts to the 2 lower holes. If a higher ride height is desired, the top 2 holes can be used.

15.

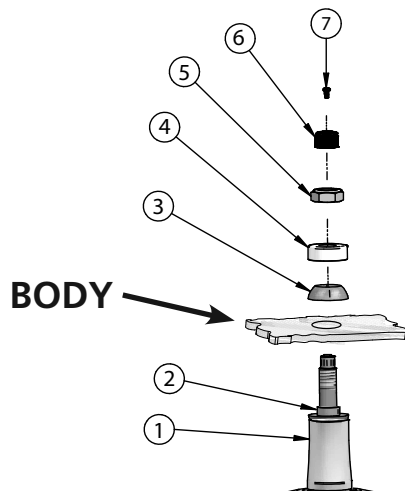

15. With the CoilOver(1) assembled, it is time to bolt them into the car. Insert the CoilOver Stud Top through the factory hole in the frame. Install the Upper Delrin Ball(2) onto the shock stud with the flat side facing the frame. Next, Install the Delrin Ball cap (3) onto the shock stud with the Concave side facing the Upper Delrin ball. Install the Nylok Nut(4) onto the shock stud and lightly tighten. There needs to be some resistance on the ball but not tight enough that it will not rotate freely. Reinstall the adjuster knob(5) using the screw (6) that was removed during step 10.

16.

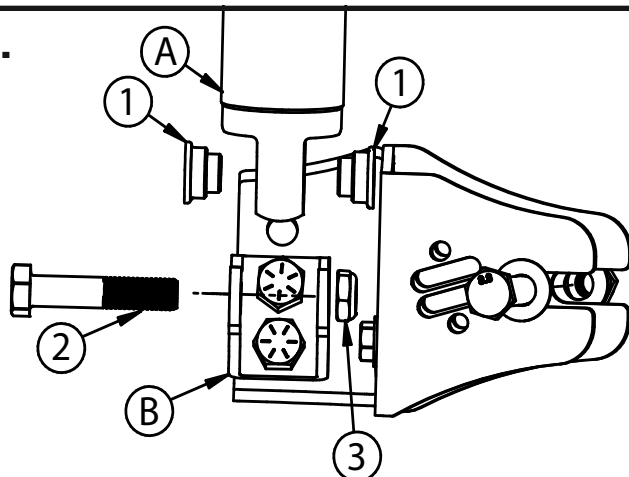

16. Install the CoilOver(A) in the Lower Shock Mount(B) using a 90002043 Spacer(2) inserted into each side of the Shock bearing. Slide the shock into the stock mounting location. It may be necessary to use the jack and raise the differential to align the mounting holes. With the mounting holes aligned, insert a $\frac{1}{2}$ "-20x $2 \frac{1}{4}$ " Bolt through the Mount and Shock. Install a $\frac{1}{2}$ "-20 **THIN** Nylok Nut (3) on the Bolt and Tighten.

Repeat the steps for the other side of the car.



CoilSpring Adjusting

Ride Height

We have designed most cars to have a ride height of about 1 1/2" lower than factory. To achieve the best ride quality & handling, the shock absorber needs to be at 40-60% overall travel when the car is at ride height. This will ensure that the shock will not bottom out or top out over even the largest bumps. Measuring the shock can be difficult, especially on some front suspensions. Measuring overall wheel travel is just as effective and can be much easier. Most cars will have 4-6" of overall wheel travel. One easy way to determine where you are at in wheel travel is to take a measurement from the fender lip (center of the wheel) to the ground. Then lift the car by the frame until the wheel is just touching the ground, re-measure. This will indicate how far you are from full extension of the shock. A minimum of 1.5" of extension travel (at the wheel) is needed to ensure that the shock does not top out. If you are more than 3" from full extension of the shock then you are in danger of bottoming out the shock absorber.

Adjusting Spring Height

When assembling the CoilOver, screw the spring retainer tight up to the spring (0 preload). After entire weight of car is on the wheels, jounce the suspension and roll the car forward and backward to alleviate suspension bind.

- If the car is too high w/ 0 preload then a smaller rate spring is required. Although threading the spring retainer down would lower the car, this could allow the spring to fall out of its seat when lifting the car by the frame.
- If the car is too low w/ 0 preload, then preload can then be added by threading the spring retainer up to achieve ride height. On 2.6" - 4" stroke shocks, up to 1.5" of preload is acceptable. On 5-7" stroke shocks, up to 2.5" of preload is acceptable. If more preload is needed to achieve ride height a stiffer spring rate is required. Too much preload may lead to coil bind, causing ride quality to suffer.



Shock Adjustment

Shock Adjustment 101- Single Adjustable

Rebound Adjustment:

How to adjust your new shocks.

The rebound adjustment knob is located on the top of the shock absorber protruding from the eyelet.

You must first begin at the ZERO setting, then set the shock to a medium setting of 12.



-Begin with the shocks adjusted to the ZERO rebound position (full stiff). Do this by rotating the rebound adjuster knob clockwise until it stops.

-Now turn the rebound adjuster knob counter clock wise 12 clicks. This sets the shock at 12. (settings 21-24 are typically too soft for street use).

Take the vehicle for a test drive.



-if you are satisfied with the ride quality, do not do anything, you are set!

-if the ride quality is too soft increase the damping effect by rotating the rebound knob clock wise 3 clicks.

Take the vehicle for another test drive.



-if the vehicle is too soft increase the damping effect by rotating the rebound knob clock wise 3 additional clicks.

-If the vehicle is too stiff rotate the rebound adjustment knob counter clock wise 2 clicks and you are set!

Take the vehicle for another test drive and repeat the above steps until the ride quality is satisfactory.

Note:

One end of the vehicle will likely reach the desired setting before the other end. If this happens stop adjusting the satisfied end and keep adjusting the unsatisfied end until the overall ride quality is satisfactory.