

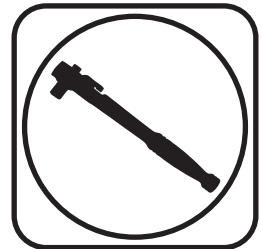

Part # 12123110 -1979-1989 Mustang



Recommended Tools



1979-1989 Mustang Front CoilOver Strut Installation Instructions

Table of contents

- Page 2..... Pre-Installation Notes
- Page 3.....Included Components
- Page 4..... Disassembly and Getting Started
- Page 5..... Upper Mount Assembly
- Page 6..... Final Assembly and Spring Adjustment & Preload
- Page 7-8..... Spring Adjustment and Strut Adjustment



PRE-INSTALLATION NOTES



SPINDLE COMPATIBILITY

These struts are only compatible with spindles from 1987-1993 V8 Mustangs.

These struts are not compatible with spindles from pre-1987 or 4-cylinder Mustangs.

K-MEMBER TRIMMING

If you are running a high degree of negative camber, the OEM K-member may require some slight trimming to avoid interference with the strut.

Some vehicles may also require the brake lines to be relocated.

See Figure A below for an example of the area that may need to be trimmed.

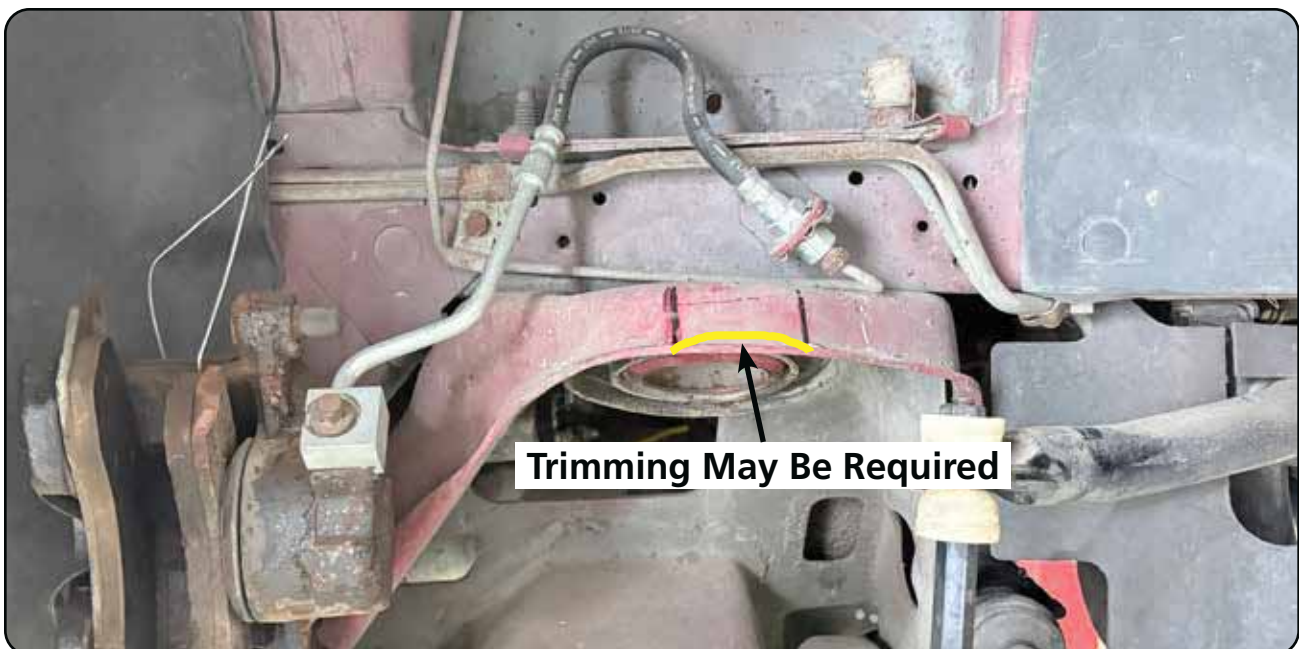
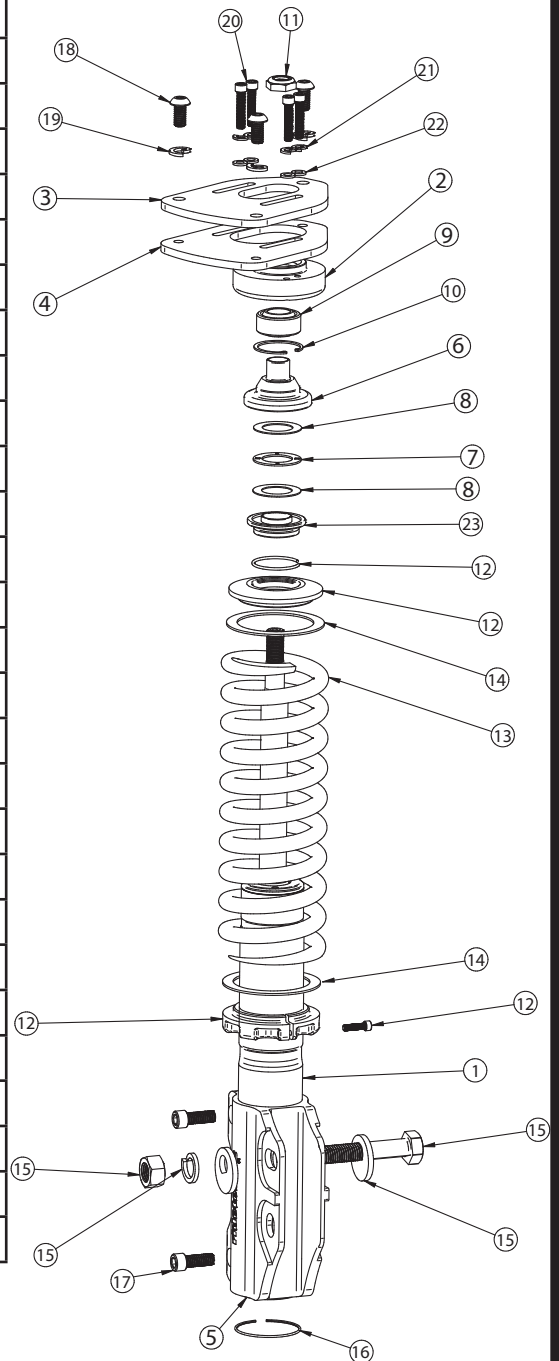

Figure A



Included ComponentsIn the box

Item #	Part #	Description	QTY
1	986-10-055	Strut Cartridge	2
2	90002470	Bearing Retaining Mount	2
3	70012092	Upper Caster Plate-Driver(Shown)	1
3	70012094	Upper Caster Plate-Pass	1
4	90002478	Lower Caster Plate-Driver (Shown)	1
4	90002479	Lower Caster Plate-Pass	1
5	90001150	Lower Strut Mount	2
6	90002368	Thrust Bearing Adapter	2
7	70010987	Thrust Bearing	2
8	70010988	Thrust Bearing Washer	4
9	90001042	Upper Mount Bearing	2
10	90000805	Bearing Snap Ring	2
11	99562003	9/16"-18 Nylok Nut	2
12	803-00-199	Coil Spring Retaining Kit	2
13	59100200	CoilSpring	2
14	70010828	Delrin Coil Spring Washers	4
15	90000801	Eccentric Bolt	2
16	038-01-035	Strut Retaining Ring	2
17	99371042	3/8"-16 x 1" SHCS	6
18	99371029	3/8"-16 x 3/4" BHSC	6
19	99373010	3/8" Split Lock Washer	6
20	99251012	1/4"-20 x 1 1/4" SHCS	8
21	99253009	1/4" Flat Washer	8
22	99253007	1/4" Split Lock Washer	8
23	90002365	Coil Spring ro Bearing Adapter	2
	90002263	Tube Red Loctite	1
	90002276	Tube Anti-sieze	1





Disassembly

1. This kit will replace the OEM Strut, Coil Spring, and Upper Strut Mount. These items will need to be removed from the car. It will be necessary to disconnect the Swaybar from the Lower Control Arm and remove the Disc Brake Caliper from the spindle, **DO NOT LET THE CALIPER HANG BY THE BRAKE LINE.** Refer to the factory service manual for disassembly procedure...
2. Support the front hub and control arm assembly and remove the (2) struts bolts(retain hardware) that attach the strut to the spindle.
3. Remove the (3) nuts holding the upper strut mount to the car body. **DO NOT REMOVE THE CENTER NUT.**
4. Remove strut assembly from the car.

Getting Started

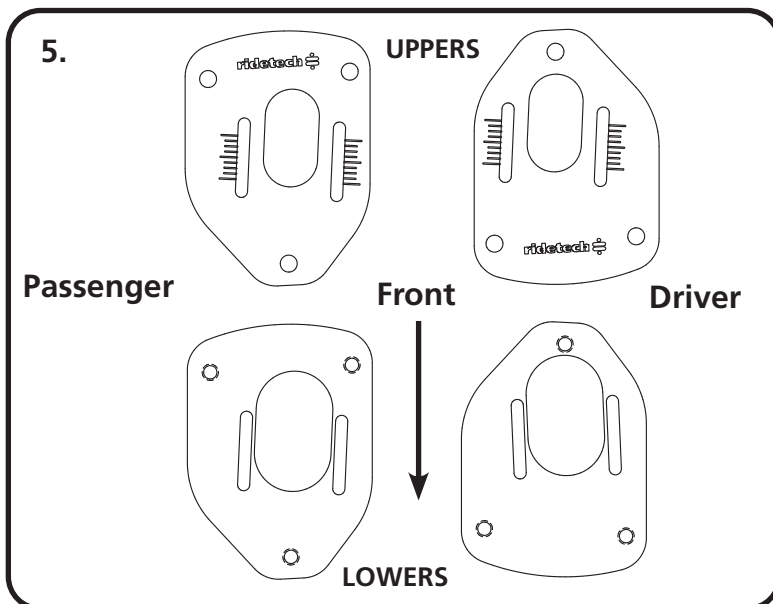

5. The upper strut mount provided in this kit has been designed to provide the ability to get more caster adjustment than the OEM setup. Camber adjustment is done at the spindle mount. The Upper Caster Plate consists of 2 Plates per side and they are specific to each location. The Steel Plate is installed on the bottom side of the Strut Tower and the Aluminum Plate is installed on the top of the strut tower. The Aluminum Upper Plate is installed with the Ridetech Logo readable from the front of the car. If the logo is upside down when standing at the front of the car, the plate is installed on the incorrect side.

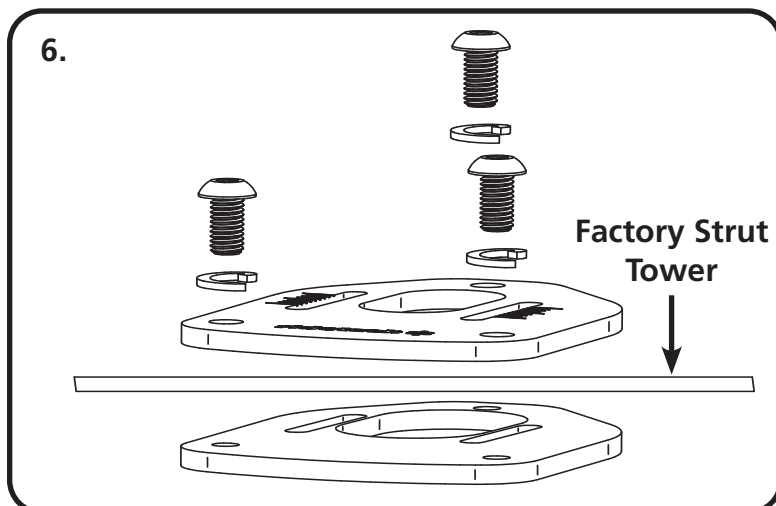

6. Use Illustration 6 to help you determine the correct position and orientation of the Caster Plates. Position the Steel Plate on the bottom side of the Factory Strut Tower. Lay the Aluminum Upper Plate on top of the Strut Tower aligning the 3 holes with the holes in the Tower. Apply Red Loctite to (3) 3/8" x 3/4" Button Head Bolts. Install a 3/8" Lock Washer on each Bolt and thread one in each hole of the Upper & Plate. Tighten all 3 bolts on each side. The slots in the Upper & Lower Plates should line up.



Upper Mount Assembly

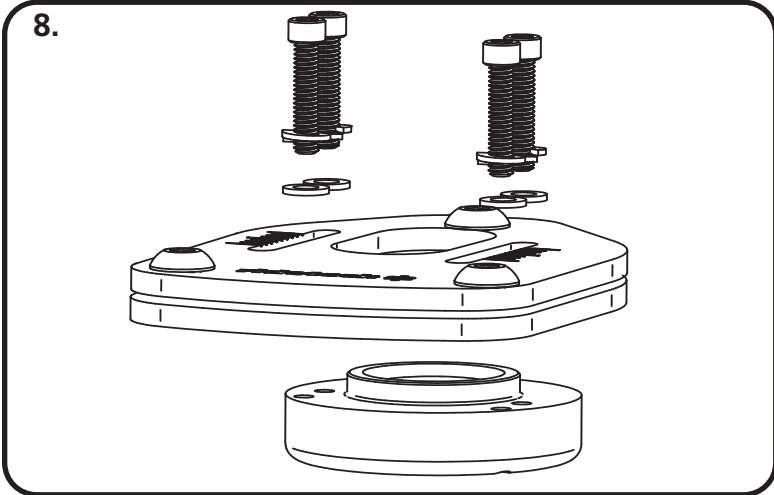

8. Attach the Bearing Housing to the Caster Plate Assembly. The Housing is positioned with the 4 threaded bolt holes to the front of the car lining 2 holes up with each slot. Insert the housing up from the bottom. Apply Antiseize to the threads of each of the (4) 1/4" x 1 1/4" Socket Head Bolts. Install a 1/4" Lock Washer and Flat Washer on each bolt. The bolts will be inserted through the caster plate with 2 bolts in each slot threading into the Bearing Housing.

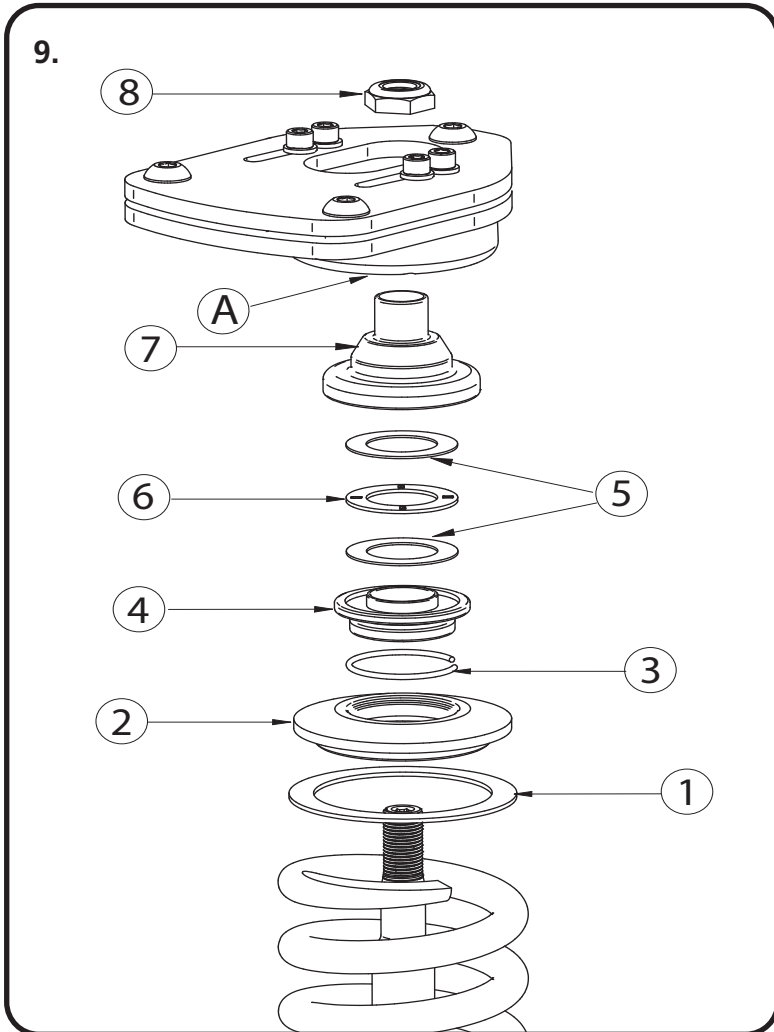

9. Remove the Adjuster Knob from the Strut shaft for assembly. With the CoilSpring installed on the Strut, bolt the strut assembly into the upper mount (A), see diagram 11 for assembly order.

1. Delrin CoilSpring Washer
2. Upper CoilSpring Cap
3. CoilSpring Cap Retaining Ring (Installed On #4 CoilSpring to Bearing Adapter)
4. CoilSpring to Bearing Adapter
5. Torrington Bearing Races
6. Torrington Bearing
7. Bearing Adapter (Small Diameter Up)
8. 9/16" Locknut

Assemble components and install into upper mount tightening upper nut. Reinstall upper adjustment knob.



Assembly

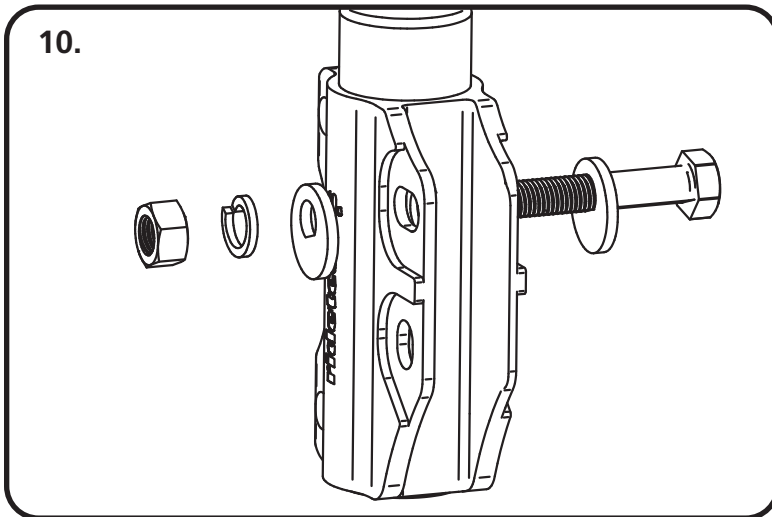

10. The lower strut mounting holes reuse the OEM Bolt. The upper slotted holes use the 16mm Eccentric Bolt provided in the kit. This Eccentric Bolt is used for camber adjustment.

NOTE: Torque Strut Mounting Bolts to 135 ftlbs

- 11.** Repeat previous steps on Passenger side.
- 12.** After both sides are installed, reattach the Sway Bar Linkage and Reinstall the Brake Caliper.
- 13.** It will be necessary to have the car aligned after installing the Ridetech Strut Setup.

Spring Adjustment and Preload

Ride Height

We have designed most cars to have a ride height of about 2" lower than factory. To achieve the best ride quality & handling, the shock absorber needs to be at 40-60% overall travel when the car is at ride height. This will ensure that the shock will not bottom out or top out over even the largest bumps. Measuring the shock can be difficult, especially on some front suspensions. Measuring overall wheel travel is just as effective and can be much easier. Most cars will have 4-6" of overall wheel travel. One easy way to determine where you are at in wheel travel is to take a measurement from the fender lip (center of the wheel) to the ground. Then lift the car by the frame until the wheel is just touching the ground, re-measure. This will indicate how far you are from full extension of the shock. A minimum of 1.5" of extension travel (at the wheel) is needed to ensure that the shock does not top out. If you are more than 3" from full extension of the shock then you are in danger of bottoming out the shock absorber.

Adjusting Spring Height

When assembling the CoilOver, screw the spring retainer tight up to the spring (0 preload). After entire weight of car is on the wheels, jounce the suspension and roll the car forward and backward to alleviate suspension bind.

- If the car is too high w/ 0 preload then a smaller rate spring is required. Although threading the spring retainer down would lower the car, this could allow the spring to fall out of its seat when lifting the car by the frame.
- If the car is too low w/ 0 preload, then preload can then be added by threading the spring retainer up to achieve ride height. On 2.6" - 4" stroke shocks, up to 1.5" of preload is acceptable. On 5-7" stroke shocks, up to 2.5" of preload is acceptable. If more preload is needed to achieve ride height a stiffer spring rate is required. Too much preload may lead to coil bind, causing ride quality to suffer.

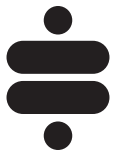

TUNING GUIDE

SINGLE-ADJUSTABLE SHOCKS



The Basics...

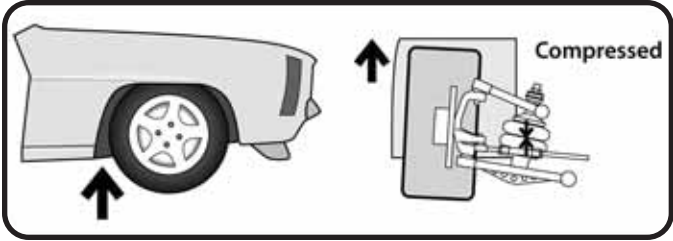

COMPRESSION

This typically occurs when you hit a bump in the road. The bump forces the wheel/tire/suspension assembly to "compress" or move upwards into the car.

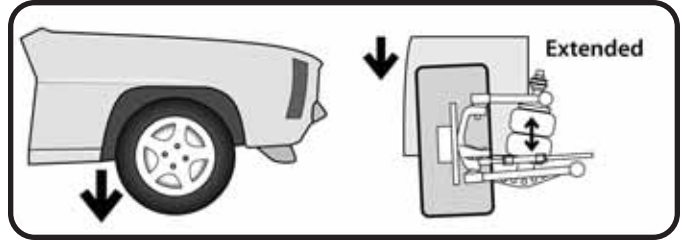

REBOUND

Rebound is the opposite of compression. This occurs when the wheel/tire/suspension assembly falls into a pothole, or simply "rebounds" from being compressed.

Where Are The Knobs?

HQ Series Shocks

- The adjustment knob is located on the top of the shock, either protruding from the side of the eyelet, or atop the stud.
- This knob provides rebound adjustment only.

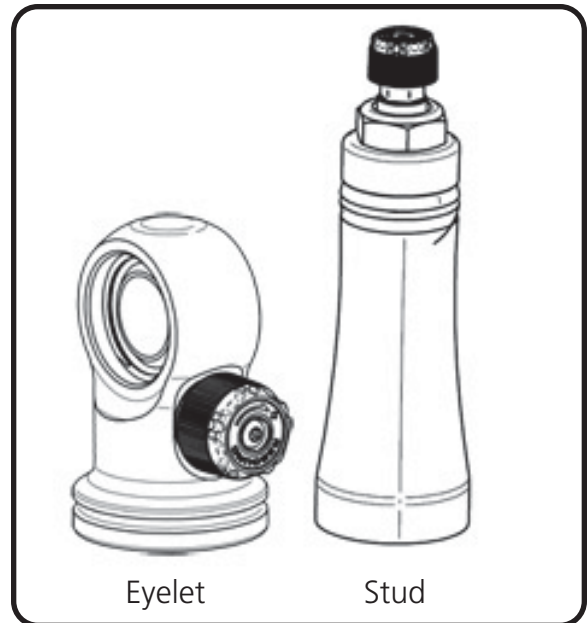

Knob Function

Counterclockwise

=
Softer

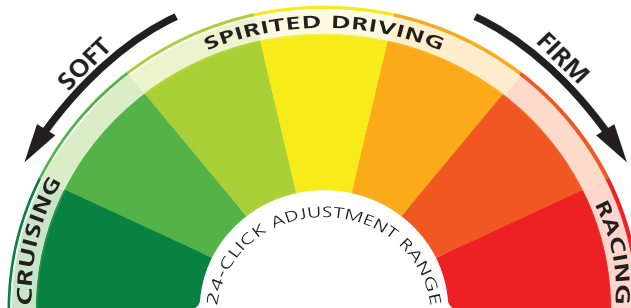

Clockwise

=
Firmer





TUNING GUIDE

SINGLE-ADJUSTABLE SHOCKS



Initial Rebound Setting

NOTE: Before jumping straight to a middle-of-the-road shock setting, we recommend you experience the full range of adjustment potential of your new shocks by first driving your vehicle at both the “full stiff” and “full soft” settings. Understanding how your shocks behave at these extremes will provide recognizable reference points as you attempt to dial in your settings.

1. Begin by setting your shocks to the “full stiff”, or minimal rebound position. You do this by turning the adjustment knob clockwise until it stops.



2. Now turn the adjustment knob counterclockwise 12 clicks. This is the approximate center of the adjustment range.



3. Take the vehicle for a test drive. Try to determine if you are experiencing any of the unwanted behaviors found at the extremes of the adjustment range. If you are satisfied with the ride quality and handling, you’re all set. Enjoy the ride!



4. If the vehicle feels too “floaty” or soft, turn the knob a few clicks clockwise to increase the damping effect.



If the ride quality is still too harsh or stiff, turn the knob a few more clicks counterclockwise to decrease the damping effect.



5. Take the vehicle for another test drive. If necessary, repeat the steps above until your desired optimal ride quality has been achieved.



General Guidelines

- The rear shocks typically have the most influence on ride quality. This is due to your seating position being closer to the rear than the front.
- Adjustments to the front shocks will generally require 3-4 clicks in any direction to be noticeable, while adjustments to the rear shocks may only require 1-2 clicks to be felt.
- Don’t be afraid to turn the knobs and experience the full adjustment range. You are not going to hurt anything and you can always go back if you adjust too far one way or the other.