



**INSTALLATION
INSTRUCTIONS**



Part # 12127099



Independent Rear Suspension System

1979-1993 Ford Mustang



www.ridetech.com
812.482.2932





**Please Read And Understand All Instructions
And Warnings Prior To The Installation Of
This Product.**



THANK YOU

Congratulations on your new Ridetech product! It's an honor that you've selected the Ridetech brand to upgrade your ride. Our products are developed around quality and performance without compromise. We're confident you'll have many years (and miles) of pure driving enjoyment.
Thank you for choosing Ridetech!

Road Map

Pre-Installation Notes	3
Recommended Tools	4
Components Listing	5
Hardware Kits	6
Exploded Views	7-10
Disassembly	11-12
Fitment Modifications	13-16
Cradle Installation	17-20
Upper Control Arms Installation	21
Differential Installation	22-24
Lower Control Arms Installation	25
Spindle/Hub Assembly	26
Steering Arm Assembly	27
Spindle/Hub Installation	28
Tie Rod Assembly/Installation	29-30
Riv-Nut Installation Guide	31
Torque & Alignment Specifications	32
Camber Lockout Plate Positions	33
Pinion Adapter Selection	34
Drive line Modifications	35

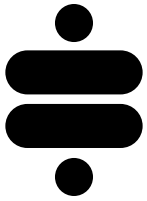

PRE-INSTALLATION NOTES PLEASE READ

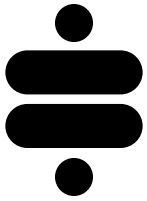

This system requires an S550 (2015+) Mustang differential (not included). You will also need a pinion flange to U-joint adapter (see page 34 for critical measurements).

This system requires you to shorten your drive shaft. See "Drive line Modifications" on page 35 for more information.

This system requires shortened S550 (2015+ Mustang) axles. These are available to purchase from Ridetech: Kit # 12129599 (Pair).

You may be required to modify or replace your exhaust system. This kit is designed to be compatible with 99-04 Cobra cat-back exhaust.

If you are still running drum brakes, you will need to install the plumbing and bracketry for a disc-brake setup. This system is designed to accept either SN95 Cobra (1999-2004) or S550 (2015+) rear brakes. The caliper bracket kits for both are available from Ridetech. Kit # 12129510 or 12129511.

We have validated fitment on the following wheel/tire combos with this system:

Wheel Size	Offset	Tire Size	Modifications
18" x 9"	+20mm	255/35 18	No modifications required. Easy fit.
18" x 9.5"	+25mm	275/35 18	Required minor rolling of fenders
18" x 10"	+25mm	275/35 18	Required significant rolling of fenders

Ridetech recommends this system be installed by a professional technician or experienced, reputable mechanic. Modification or improper installation of this product may result in loss of warranty. Proper installation and setup of your suspension is critical to the safe and enjoyable operation of your vehicle. Failure to follow the guidelines and specifications provided in these instructions may result in damage to your vehicle and/or death or serious injury to you, your passengers, or other motorists. Ridetech will not be held liable for any damage, loss or injury occurring from the use of this product outside of its intended application and design parameters.



RECOMMENDED TOOLS

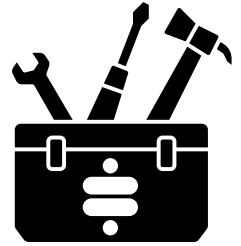

Jack Stands/Lift

Hammer

Drill & Drill Bit Set

Blue Loctite

Tape Measure

Cutting Wheel

Torque Wrench

Anti-Seize

SAE Socket/Wrench Set

Metric Socket/Wrench Set

! SAFETY FIRST !

Always use jack stands (if not using a lift). Never rely solely on a hydraulic jack to support the vehicle.

Always raise the vehicle on a clean and level surface. Use wheel chocks when necessary.

Be sure to wear proper Personal Protective Equipment (PPE) when welding.

Always wear eye protection (Z87.1) when operating power tools.

COMPONENTS LISTING

ITEM #	PART #	DESCRIPTION	QTY
1	90003611	CRADLE ASSEMBLY	1
2	90002963	BOLT MISALIGNMENT SPACER STUD	2
3	90002964	BOLT MISALIGNMENT SPACER WASHER	2
4	90003860	79-93 MUSTANG IRS TORQUE BOX SPACER	2
5	70016852	79-93 MUSTANG IRS DIFF BUSHING	4
6	90002961	FORWARD FRAME PLATE SHIM	2
7	90003867	REAR UPPER FRAME SHIM - DRIVER	1
8	90003868	REAR UPPER FRAME SHIM - PASSENGER	1
9	90002960	79-93 MUSTANG IRS DIFF SLEEVE	8
10	90003618	DIFF ADAPTER BRACKET	1
11	90003619	TIE ROD SUPPORT SLEEVE	2
12	90002112	CONTROL ARM SPACER 14GA	16
13	90003624	CONTROL ARM SPACER 10GA	32
14	90003579	UPPER CONTROL ARM - DRIVER (SHOWN)	1
15	90003580	UPPER CONTROL ARM - PASSENGER	1
16	90002967	INNER BUSHING SLEEVE	4
17	90000908	UPPER BALL JOINT	2
18	99253012	1/4 SAE FLAT WASHER BLACK	8
19	99251022	1/4-20 X 1 HCS GR8 BLACK	8
20	99252006	1/4-20 NYLON INSERT L/N BLACK	8
21	70010759	DELTRIN BUSHING	16
22	90003581	LOWER CONTROL ARM - DRIVER (SHOWN)	1
23	90003582	LOWER CONTROL ARM - PASSENGER	1
24	90002966	INNER BUSHING SLEEVE	4
25	90000898	LOWER BALL JOINT	2
26	90003620	CAMBER LOCKOUT PLATE	8
27	90003051	INNER TIE ROD	2
28	90003050	OUTER TIE ROD	2
29	90000092	TIE ROD ADJUSTER 11/16-18 THREAD 4.75"	2
30	90003612	STEERING ARM - DRIVER (SHOWN)	1
31	90003613	STEERING ARM - PASSENGER	1
32	70015751	RIDETECH SPINDLE - FORD	2
33	90003535	THREADED INSERT	4
34	70013663	HUB/BEARING ASSEMBLY - S550	2
35	90002042	Aluminum Spacer, .625" ID (Upper Shock Mount)	4
36	90002043	Aluminum Spacer, .500" ID (Lower Shock Mount)	4
37	85000008	3/8" RIV-NUT INSTALLATION TOOL	1

HARDWARE KITS

Hardware Kit: 99010260			
ITEM #	PART #	DESCRIPTION	QTY
CRADLE TO FRAME			
38	99371005	3/8"-16 X 1.25" HEX BOLT GR8	30
39	99373006	3/8"-16 SPLIT LOCK WASHER GR8	30
40	99373002	3/8"-16 SAE FLAT WASHER GR8	30
41	99372007	3/8"-16 RIV NUTS	30
42	99621037	5/8-18 X 7.0 HCS GR8	2
43	99622001	5/8-18 NYLON INSERT GR8	2
44	99623001	5/8 SAE FLAT WASHER GR8	4
	85000007	17/32" Drill Bit	1
SHOCK TO CRADLE			
45	99621015	5/8-18 X 4 1/2 HCS GR8	2
46	99623001	5/8 SAE FLAT WASHER GR8	4
47	99622006	5/8-18 THIN NYLON JAM NUT	2
SHOCK TO LOWER CONTROL ARM			
48	99501050	1/2-13 X 2 1/2 HCS GR8	2
49	99503014	1/2 SAE FLAT WASHER GR8	4
50	99502009	1/2-13 USS NYLOK NUT GR8	2
LOWER CONTROL ARM TO CRADLE			
51	99501077	1/2-13 x 5 1/4" HEX BOLT GR8	4
52	99502009	1/2-13 NYLOK NUT GR8	4
53	99503014	1/2" SAE FLAT WASHER GR8	10
UPPER CONTROL ARM TO CRADLE			
54	99501063	1/2-13 X 4 1/4 HCS GR8	4
55	99503014	1/2" SAE FLAT WASHER GR8	8
56	99502009	1/2-13 NYLOK NUT GR8	4
DIFFERENTIAL TO CRADLE			
57	99141008	M14-2.0 x 50mm HEX BOLT GRADE 10.9	2
58	99143001	M14 Flat Washer; Grade 10.9	10
59	99141010	M14-2.0 x 100mm Hex Bolt; Grade 10.9	2
60	99141005	M14-2.0 x 120mm Hex Bolt; Grade 10.9	2
61	99142002	M14-2.0 NYLON INSERT L/N; Grade 10.9	4
TIE ROD BRACE SUPPORT			
62	99372003	3/8-16 THIN NYLON NUT	2
63	99373002	3/8 SAE FLAT WASHER GR8	2
64	99371066	3/8-16 X 2 3/4 HCS GR8	2

Hardware Kit - 99010265			
ITEM #	PART #	DESCRIPTION	QTY
TOE ADJUSTMENT			
65	99800001	11/16 SAE Left Hand Thread Jam Nut	2
66	99800005	11/16 SAE Right Hand Thread Jam Nut	2
67	99501076	1/2-13 x 2.5" -Black-OxideSteel Socket Head Screw	4

Hardware Kit: 99010231			
ITEM #	PART #	DESCRIPTION	QTY
HUB TO SPINDLE			
68	99121018	M12-1.5 x 40MM -Black-Oxide Alloy Steel Socket Head Bolt	8

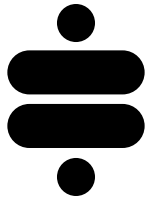

EXPLODED VIEWS CRADLE: VIEW #1

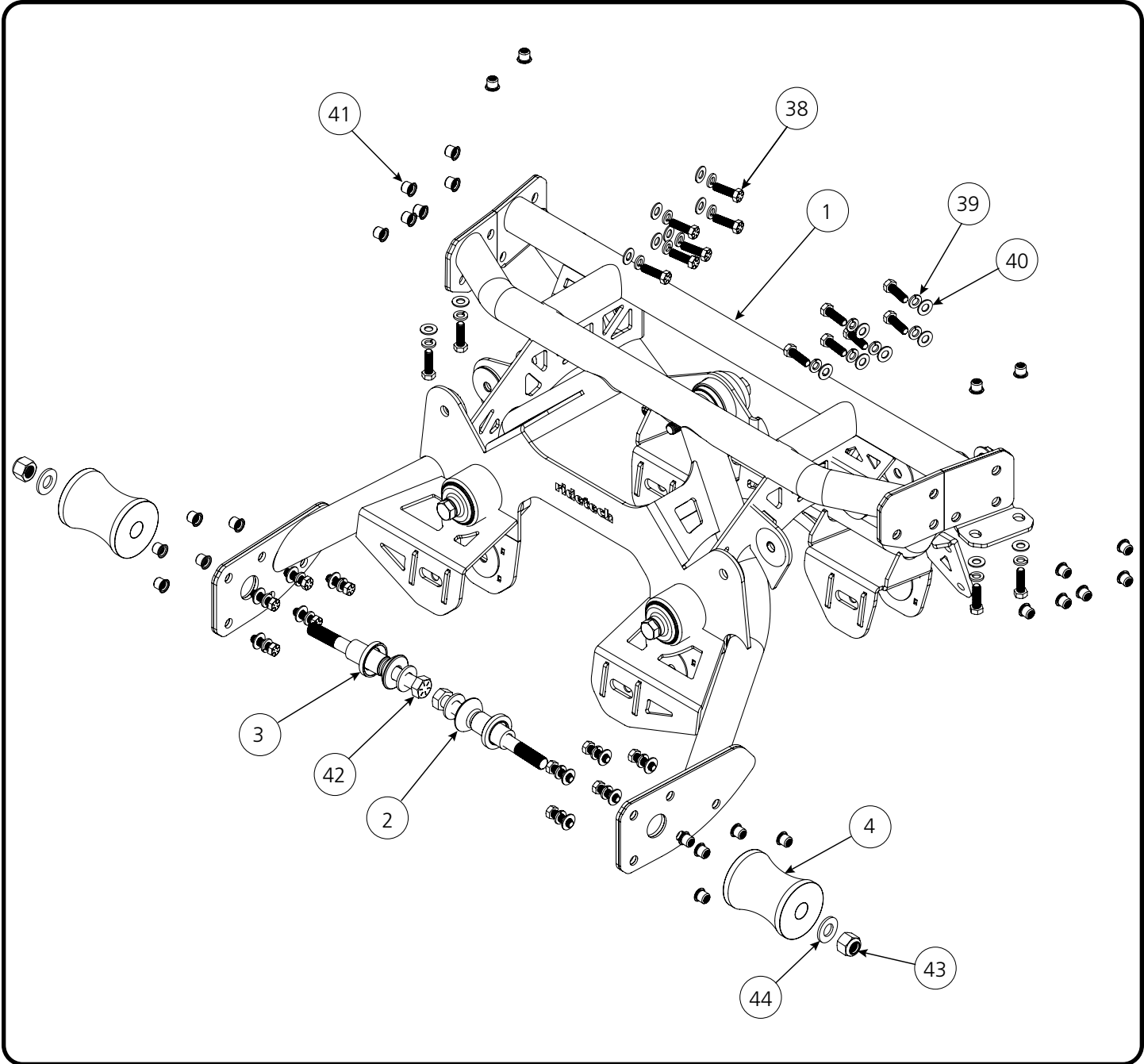
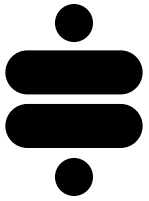

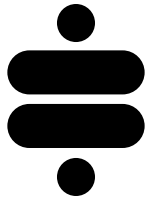

EXPLODED VIEWS CRADLE: VIEW #2

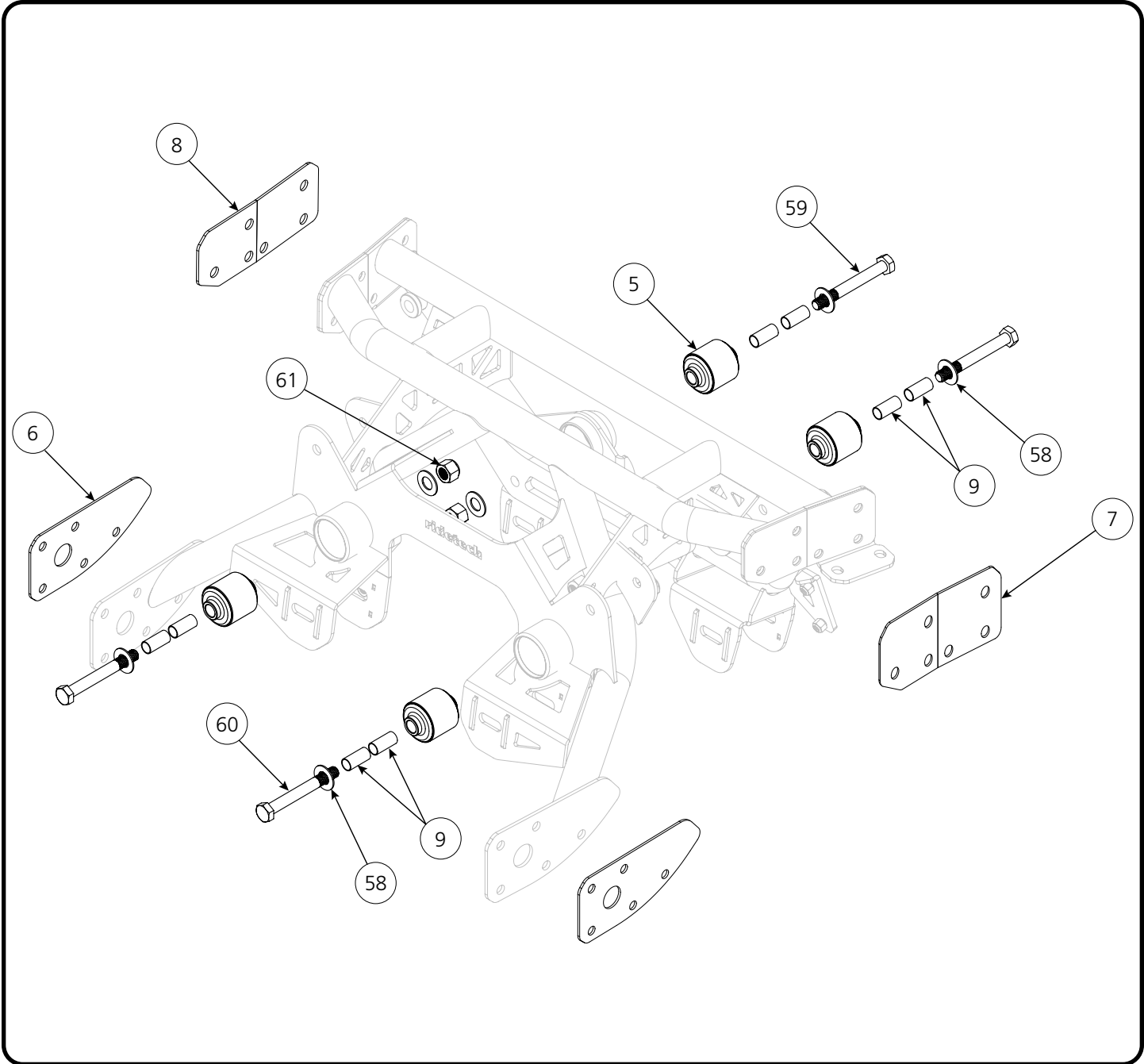
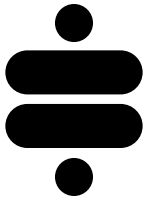

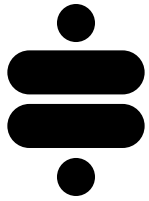

EXPLODED VIEWS UPPER CONTROL ARM

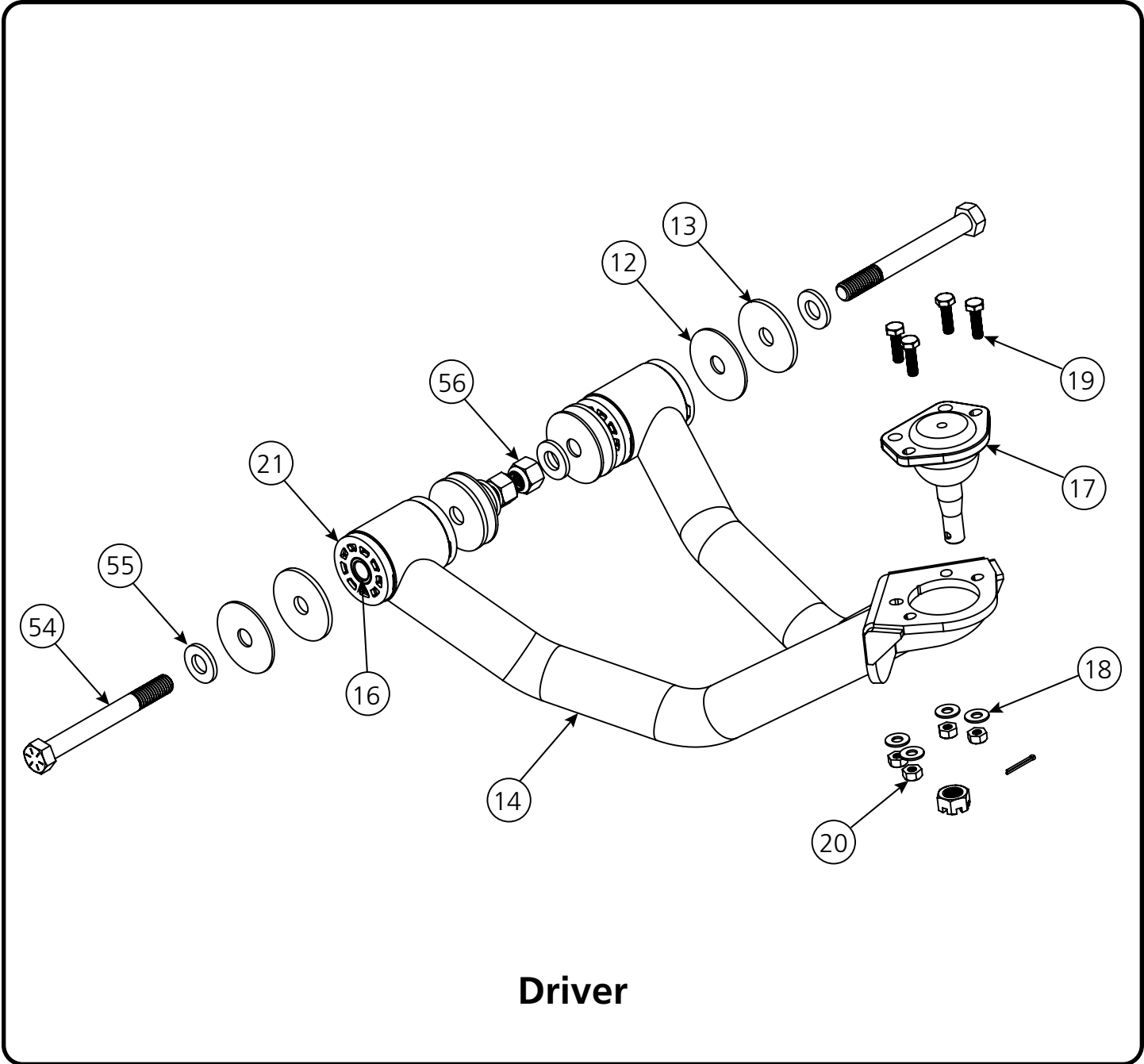
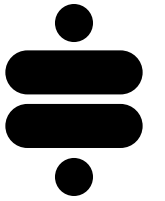

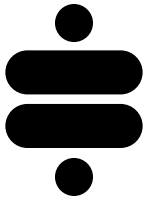

EXPLODED VIEWS

LOWER CONTROL ARM/TIE ROD/HUB/SPINDLE

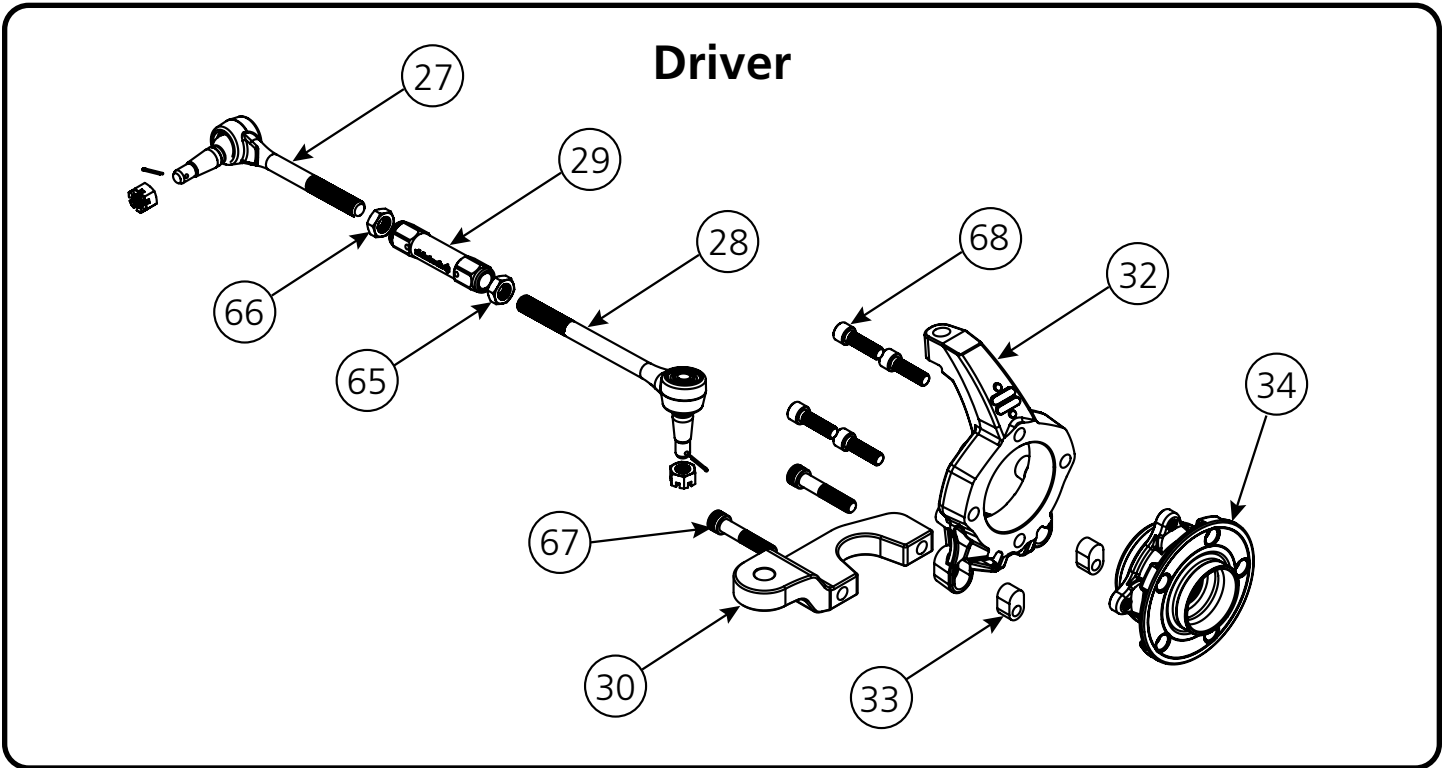
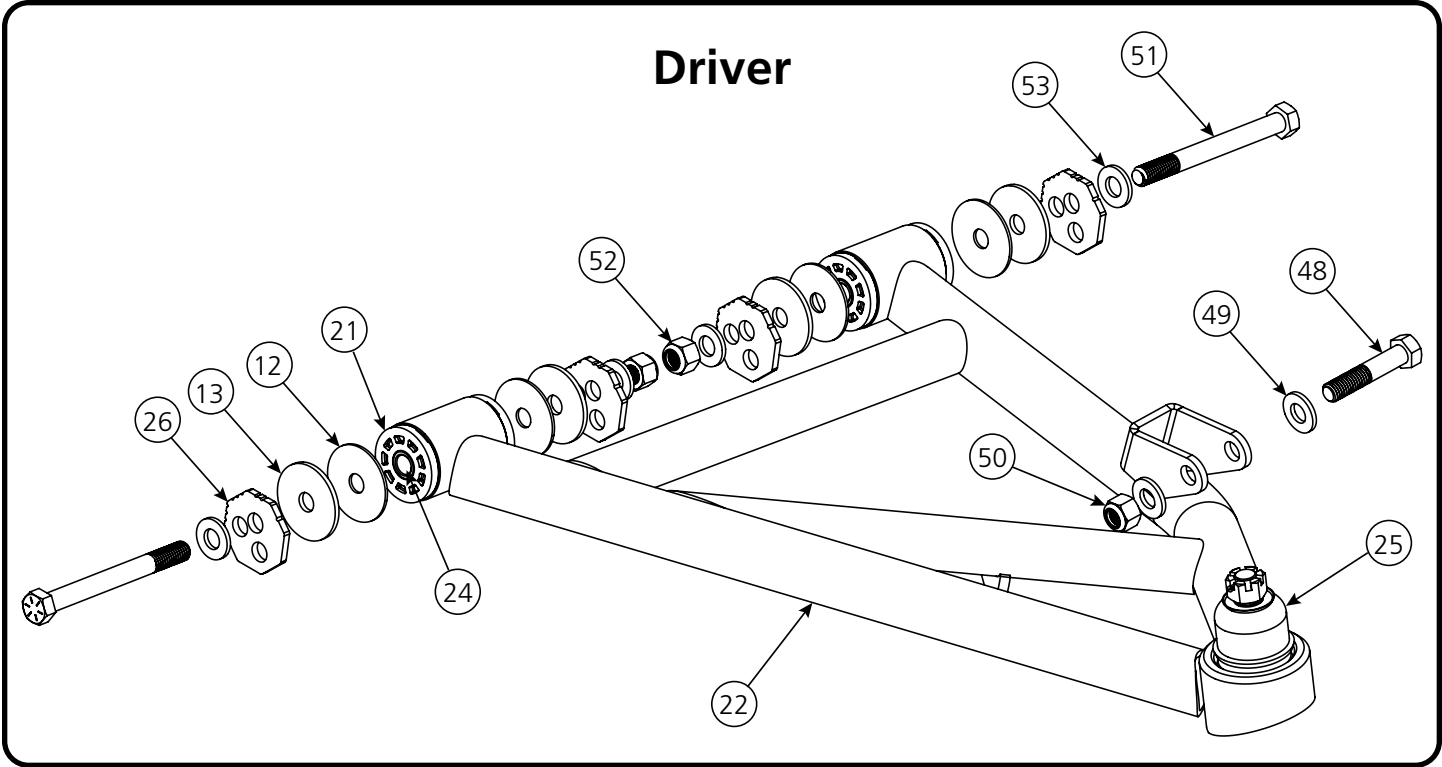
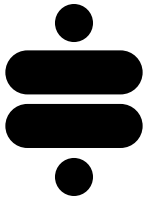

Disassembly

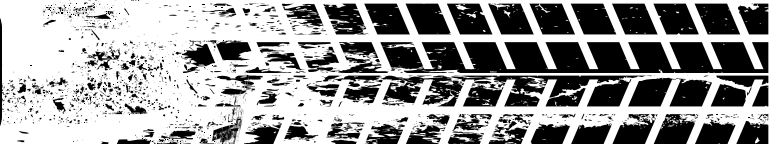

1. Raise the vehicle by the frame to a safe and comfortable working height.
2. Remove the driveshaft. A shortened driveshaft will be required upon reassembly.
3. Remove the rear sway bar.
4. Support the rear end/differential. Remove the rear shocks and coil springs. Disconnect the upper and lower control arms from the rear end.
5. Remove the rear end. **Don't forget to disconnect the rear brake line.**
6. Remove the tail pipes. Your existing tail pipes will mostly likely need to be modified or replaced. This IRS system is compatible with 99-04 Cobra cat-back exhaust.
7. Finish removing the upper and lower control arms from the body.

8. Remove the exhaust hanger next to each of the upper control arm mounts (Figure 1).



Figure 1

9. Remove the pinion snubber and mount (Figure 2).



Figure 2

Disassembly

10. Remove the OEM fuel filter from its retaining bracket, and then remove the retaining bracket (Figure 3).

The fuel filter will be repositioned once the IRS cradle is installed.

11. On the passenger side frame rail, right above the axle, drill out the rivet and remove the emissions line retaining clip (Figure 4).

The line may be repositioned once the IRS cradle is in place.

12. Remove the OEM axle bump stop on each side. We did this by drilling out the spot welds (Figure 5). There are 4 spot welds on the side of the frame rail, and 2 on the bottom.

Figure 6 below shows the bump stop removed.



Figure 3



Figure 4



Figure 6



Figure 5

Fitment Modifications

13. With the bump stops removed and out of the way, remove the gusset at the front and rear of the OEM shock mount.

Drill out the spot welds where the gusset attaches to the frame rail (Figure 7).

Then use a cutting wheel to make a horizontal cut along the top of each gusset (Figure 8).

The gussets should now be removable (Figure 9).

A bit of "persuasion" with a hammer might be necessary.

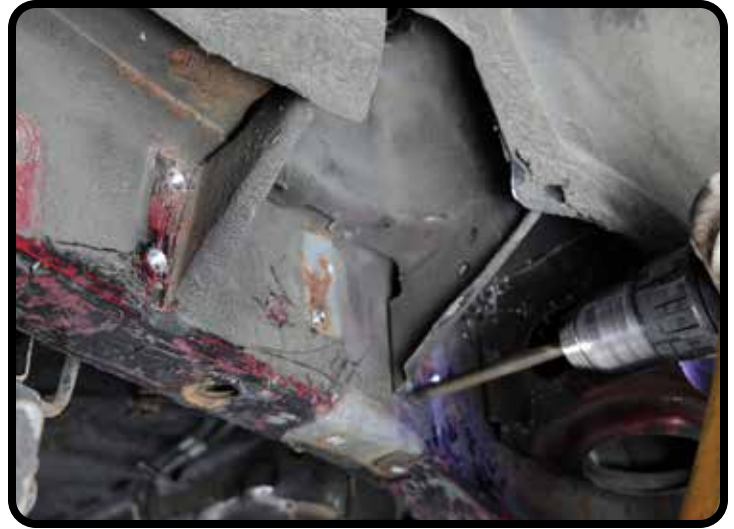

Figure 7



Figure 8



Figure 9

Fitment Modifications

14. Once the gussets are removed, trim the lower corners of the OEM shock mount opening to approximately 45-degree angles as shown in Figure 10.

Also make two horizontal cuts near the top of the shock mount as shown in Figure 10. The cuts only need to go as deep as the vertical sides of the shock mount.

15. After making the two horizontal top cuts, use a hammer to bend the two flanges inward and flush against the shock mount as shown in Figure 11.

When finished, the opening should look similar to Figures 12 and 13.

16. Repeat steps 13-15 on the opposite side.



Figure 10



Figure 11



Figure 13



Figure 12

Fitment Modifications

14. Each of the OEM upper control arm mounts (Figure 14) needs to be cut for clearance.

You may find it easier to remove the angled flanges first to make access easier for the final cuts (Figure 15).

We made multiple cuts and shaped the mount by removing a section at a time.

We drilled out the spot welds to remove the back portion of the mounts (visible in Figures 16 & 17).

Trim the mounts until they look similar to the final product shown in Figures 16 and 17.

Figure 16 = Passenger

Figure 17 = Driver



Figure 14



Figure 15



Figure 17



Figure 16

Fitment Modifications

15. Remove the OEM brake line bracket.

We found it easiest to drill out the two rivets shown in Figure 18.

NOTE: If you still have the OEM drum brakes setup, you will need to add plumbing and bracketry to accommodate disc brakes.

16. Drill out each of the OEM lower control arm mounting holes to 5/8" (Figure 19).



Figure 18



Figure 19

Cradle Installation

17. Raise the IRS cradle into position in the car. A transmission jack works well for this (Figure 20).

You may have to manipulate the brake and emissions lines a bit to get the cradle into position without snagging or damaging them.

18. Line up the large hole in the center of the front mounting flanges with the OEM lower control arm mounting holes.

If there is a gap between the mounting flange and the frame rail, insert a 90002961 shim as shown in Figure 21. The shims are included with this kit.

Align the holes in the shim with the holes in the flange on the cradle.

19. Install a 90002963 misalignment spacer onto a 5/8"-18 x 7" bolt from the 99010260 Hardware Kit. The large OD of the spacer seats against the bolt head.

Then install a 90002964 washer onto the misalignment spacer. The concave side of the washer seats against the convex surface of the spacer. See Figure 23.



Figure 20



Figure 21

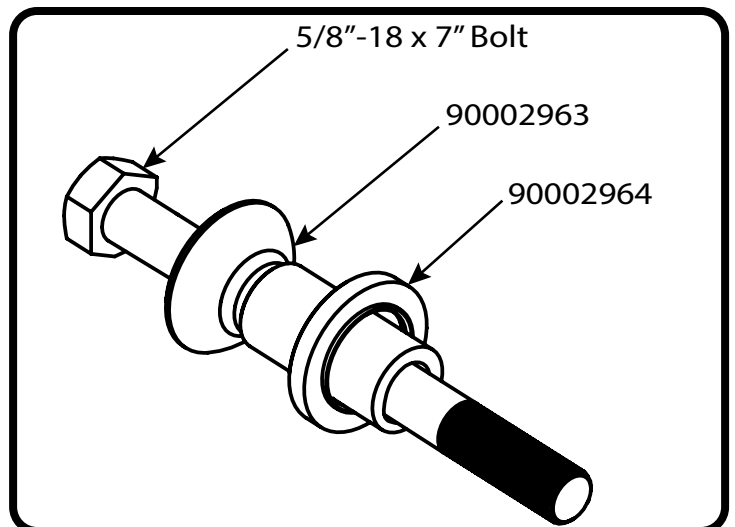

Figure 23

Cradle Installation

20. Position a 90003860 spacer in the OEM lower control arm mount location (Figure 24), and then insert the bolt assembly into the large center hole in the cradle flange and through the frame/spacer/mount (Figure 25).

You might have to manipulate the large spacer a bit to get all of the holes to align. A few light taps here and there with a hammer may be necessary.

Once the bolt is fully inserted, install a 5/8" washer and 5/8"-18 nylok nut on the bolt. You may snug the hardware for now.

21. Repeat steps 19 and 20 on the opposite side.

22. Ensure that each of the horizontal mounting flanges of the cradle is flush against the bottom of the frame and that the cradle is firmly supported (Figure 26).

We chose to install one self-tapping screw on each side to temporarily secure the cradle for the next steps (Figure 27).



Figure 24



Figure 25



Figure 27



Figure 26

Cradle Installation

23. Using some form of writing utensil, scribe, etc., mark the location of all mounting holes on each of the cradle mounting flanges (Figures 28 & 29). Don't forget the horizontal plate at the bottom of the frame rail on the rear flange.

Ensure you are marking the holes clearly enough to easily be able to identify the center of each hole. Divoting each location with a few spins of a drill bit also works well.

24. Once all the hole locations are clearly marked, remove the cradle from the vehicle.

25. Using the supplied 17/32" bit, drill out all of the marked mounting holes (Figure 30).

26. Using the included Riv-Nut installation tool, install a Riv-Nut from the 99010260 Hardware Kit in each of the drilled out mounting holes (Figure 31).

There are 26 Riv-Nuts to install. The kit includes 4 extras.

Refer to the Riv-Nut installation Guide on page 31 for the installation procedure.



Figure 28



Figure 29



Figure 31



Figure 30

Cradle Installation

27. Reposition the cradle in the car and repeat Steps 17-21.

Do not forget to reinstall the shims on the front cradle mounts if they were required in the initial fitment.

Blue Loctite is recommended for the bolts in Steps 28-30 below.

28. Place a 3/8" lock washer and flat washer on (4) 3/8"-16 bolts and install two bolts in each of the horizontal mounting flanges as shown in Figure 32. Do not tighten yet. The cradle must be allowed to "float" a little as you install the remaining fasteners.

29. Place a 3/8" lock washer and flat washer on (10) 3/8"-16 bolts and install five bolts in each of the front mounting flanges as shown in Figure 33. Again, leave hand tight for now.

The large center bolt should not be tightened yet. Loosen it if you are having difficulty getting the 3/8" holes to align.

30. Place a 3/8" lock washer and flat washer on (12) 3/8"-16 bolts and install six bolts in each of the rear upper mounting flanges as shown in Figure 34.

If there is a gap between the mounting flange and the frame rail, insert a 90003867 (Driver) shim and 90003868 (Passenger) shim before installing the bolts. The shims are included with this kit.

31. Torque all 26 of the 3/8" mounting bolts to **33 ft-lbs.**

32. Torque the two large 5/8"-18 bolts to **162 ft-lbs.**



Figure 32



Figure 33



Figure 34

Upper Control Arms Installation

33. Once all cradle fasteners have been torqued, give the cradle and its surroundings a quick scan to ensure no lines or hoses have been pinched or damaged.

We used zip ties to manage and secure most of the rerouted lines and hoses (Figure 35).

34. Place a 1/2" washer on each of (2) 1/2"-13 x 4.5" bolts. Position the upper control arm into the mounting flanges on the cradle (Figure 36). The orientation of the ball joint is offset toward the rear of the car (Figure 37).

Install a combination of 90002112 and/or 90003624 spacers on each side of the control arm bushings (Figure 38).

You may have to play with different combos to fill the gap and center the arm.

Insert the 1/2"-13 x 4.5" bolt through the flange/spacers/arm, install a 1/2" washer and 1/2"-13 Nylok nut on each bolt and torque to **75 ft-lbs.**

Repeat on the opposite side.



Figure 35



Figure 36



Figure 38

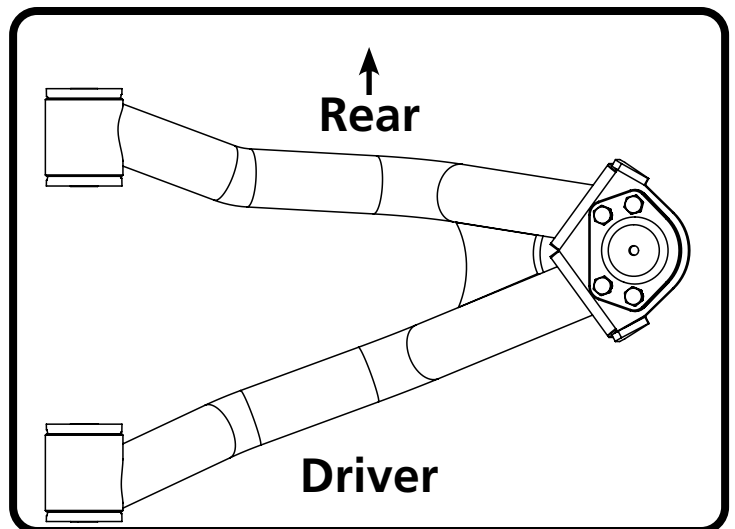

Figure 37

Differential Housing Installation

35. Insert a M14-2.0 x 100mm bolt with M14 flat washer into each of the two rear bushings on the cradle as shown in Figure 39.

Loosening the fuel tank might provide a little more room for inserting the bolts.

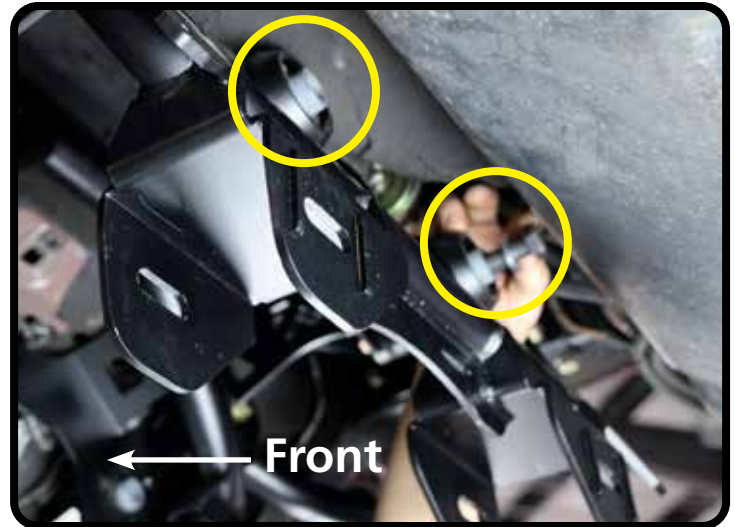

Figure 39

36. From the front side of the bushing, slide (2) 90002960 sleeves over each of the M14 bolts from step 35 above (Figure 40). We recommend applying antisieze to the outside of the sleeves.

Be sure to hold the head of the bolts so they do not push back out of the bushing when inserting the sleeves.



Figure 40

37. Using (2) M14-2.0 x 50mm bolts with M14 flat washers, attach the 90003618 adapter plate to the rear of the differential (Figure 41).

Leave the bolts slightly loose for now. The differential will be easier to install if the plate is allowed to flex a little.



Figure 41

Differential Housing Installation

38. Slowly raise the differential into position in the cradle and align the two holes in the differential adapter plate with the two rear cradle bushings.

Slide the bushing bolts from Step 35 into the adapter plate holes but do not install nuts and tighten yet.

39. Slide (2) 90002960 sleeves into each of the cradle front bushings (Figure 43). We recommend applying antisieze to the outside of the sleeves.

40. Insert a M14-2.0 x 120mm bolt with M14 flat washer through each of the front mounting flanges of the differential housing and through the front bushings on the cradle (Figure 44).

Install an M14 washer and M14-2.0 Nylok nut on each bolt and torque to **100 ft-lbs.**



Figure 42



Figure 43



Figure 44

Differential Housing Installation

41. Tighten the bolts attaching the adapter plate to the rear of the differential (Figure 46).

42. Install an M14 washer and M14-2.0 Nylok nut on each of the rear bushing bolts and torque to **100 ft-lbs** (Figure 47).

43. From the 99010260 Tie Rod Brace Support Hardware Kit, install a 3/8" flat washer on a 3/8"-16 x 2.75" bolt.

Position a 90003619 Support Sleeve between the tie rod mount plate and front plate of the cradle. Figure 47 shows the location of the supports in red, viewed from the bottom looking up, with hardware exploded.

Insert the 3/8" bolt/washer through the plate & sleeve from the rear. Install a 3/8" thin nylok nut and torque to **32 ft-lbs**.

Repeat on the opposite side.

NOTE: The differential must be mounted before installing the supports sleeves.



Figure 45



Figure 46

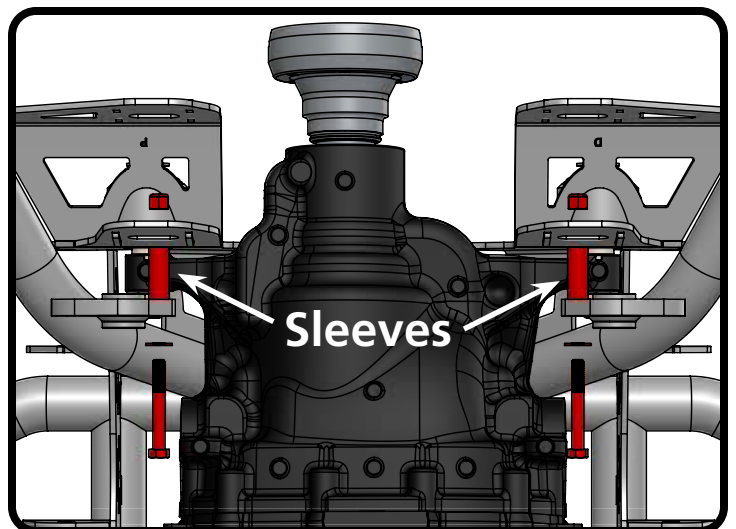

Figure 47

Lower Control Arms Installation

44. This kit contains camber lockout plates for the lower control arms. We recommend starting with the plate orientation shown in Figure 48. This should provide you with approximately 1 degree of negative camber.

Note the tick marks on the edges of the plate to help differentiate the orientations.

Refer to the chart on page 33 for additional plate orientations and their correlating camber values.

45. Install a 1/2" flat washer followed by a 90003620 Lockout Plate on each of (2) 1/2"-13 x 5.25" bolts.

Position the lower control arm in the mounting flanges on the cradle. The shock mount on the arm is oriented toward the rear of the car (Figure 49).

Install a combination of 90002112 and/or 90003624 spacers on each side of the control arm bushings (Figure 50). You may have to play with different combos to fill the gap and center the arm.

46. Insert the 1/2"-13 x 5.25" bolt through the mounts/arm, then install another lockout plate followed by a 1/2" washer and 1/2"-13 Nylok nut on each bolt and torque to **75 ft-lbs.**

NOTE: Ensure that the lockout plates are all oriented to the same camber position. The plates on either side of each clevis should mirror each other.

Repeat on the opposite side.

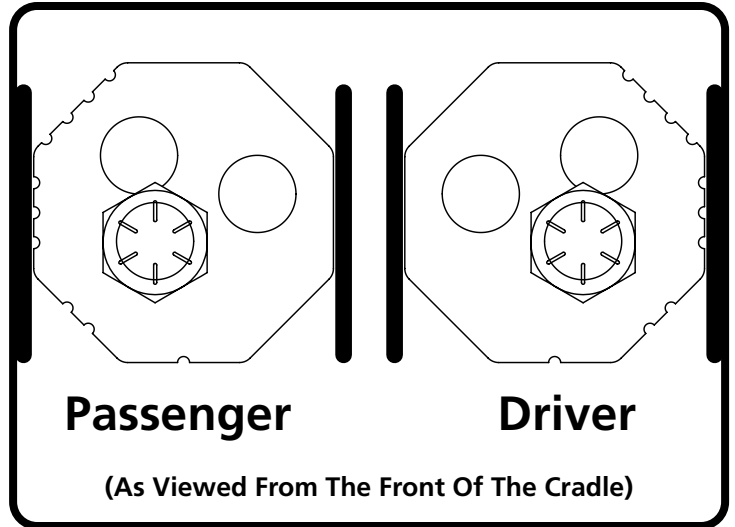

Figure 48

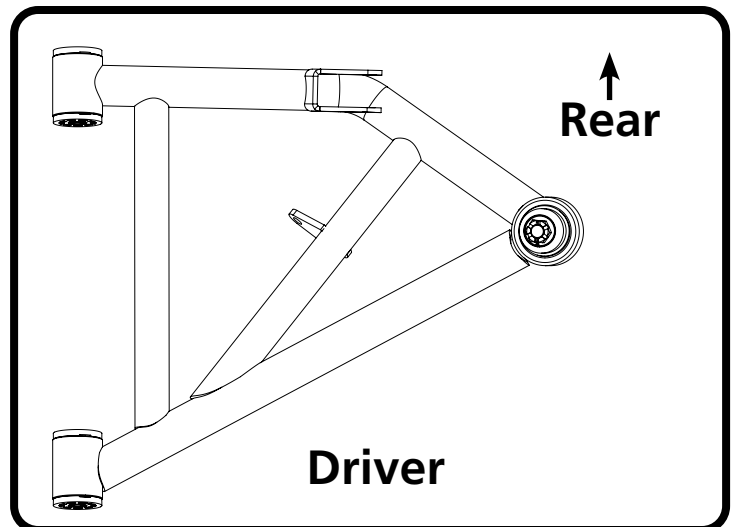

Figure 49

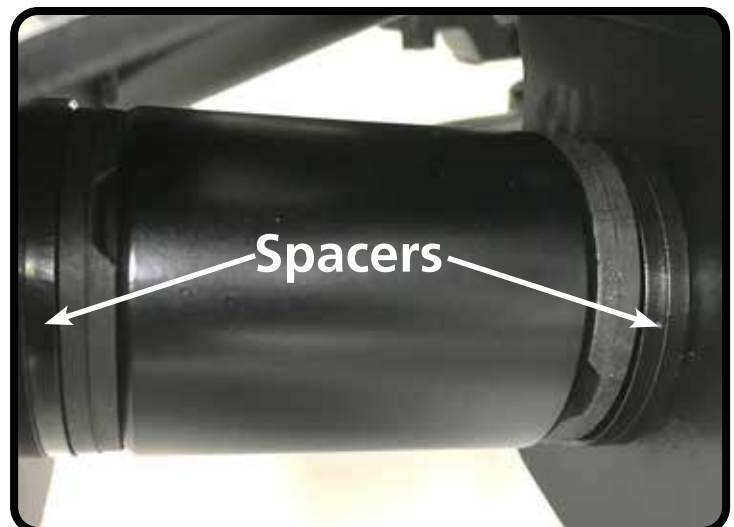

Figure 50

Axle Installation Spindle/Hub Assembly

47. Remove the spline plugs from the differential (if applicable) and install the axle on each side (Figure 51).

If you are installing the Ridetech 12129599 Axle Shaft Set (purchased separate), match the #s below to the #s etched on each shaft to identify driver/passenger.

Driver: VS 8326NS 240510

Passenger: VS 8327NS 240510

48. Position the Ridetech spindle onto the hub/bearing assembly and align the mounting holes in the hub/bearing assembly with the four countersunk holes in the spindle (Figure 52).

49. Apply Loctite to (4) M12-1.5 x 40mm socket-head bolts from the 99010231 hardware kit.

Install the four bolts attaching the spindle to the hub (Figure 53).

Tighten the bolts in a criss-cross pattern and torque to **99 ft-lbs**.

Repeat for the other hub & spindle.



Figure 51



Figure 52



Figure 53

Steering Arm Assembly

50. Apply Loctite to (2) 1/2"-13 x 2.5" socket-head bolts from the 99010265 hardware kit.

Install the bolts into the countersunk holes of a steering arm and position the steering arm onto the spindle as shown in Figure 54.

The offset portion of the steering arm should be oriented toward the top of the spindle.

51. While holding the steering arm in position, insert a 90003535 threaded insert into the recessed opening at the bottom of the hub side of the spindle (Figure 55).

The inserts should be oriented with the threaded hole toward the top of the spindle. See Figure 56.

Thread the steering-arm bolts into the inserts and torque to **93 ft-lbs**.

Repeat for the opposite side.

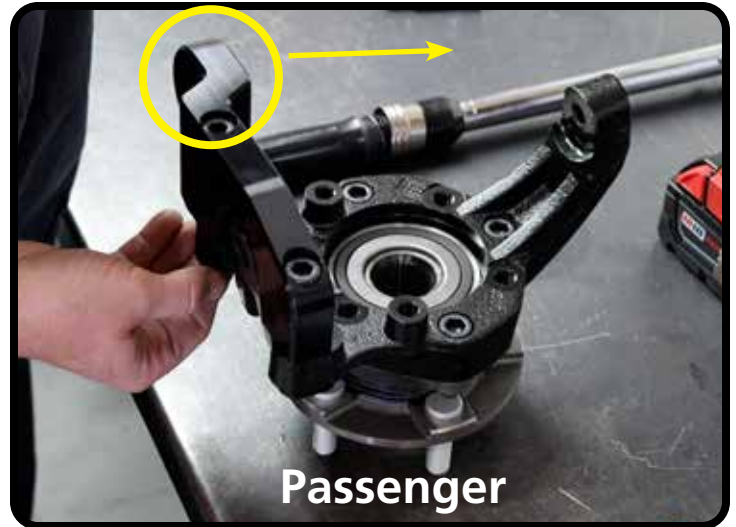

Figure 54



Figure 55



Figure 57



Figure 56

Spindle/Hub Installation

52. Position the hub/spindle assembly onto the lower control arm ball joint. The offset portion of the steering arm should be to the front of the car.

Thread the castle nut onto the ball joint but do not tighten yet (Figure 58).

53. Swing the lower control arm up and feed the axle through the hub/bearing/spindle assembly (Figure 59).

Then pull the upper control arm down and insert the upper ball joint stud into the top of the spindle (Figure 59).

Thread the castle nut onto the upper ball joint and torque to **50 ft-lbs**.

If necessary, tighten the nut to line up the cotter pin holes. Install and bend the cotter pin.

Torque the lower ball joint nut to **65 ft-lbs**.

If necessary, tighten the nut to line up the cotter pin holes. Install and bend the cotter pin.

54. Install the axle nut, but we recommend leaving the nut hand tight for now. This will leave some play in the axle shaft and make the brake caliper brackets easier to install.

Repeat steps 52-54 on the opposite side.



Figure 58



Figure 59



Figure 60

Tie Rod Assembly

55. Prior to installing the coilovers and tie rods, move the control arms through their full range of motion to ensure no additional trimming/modification is required.

On this particular install, we discovered a point of potential interference that required some additional minor trimming (Figure 61).

56. Now is good time to install your Ridetech Coilovers or Shockwaves. The mounting hardware and bearing spacers are included in this kit. Refer to the install instructions included with your shock kit.

57. Assemble the tie rod assemblies as illustrated in Figures 62 and as outlined below.

From the 9010265 Hardware Kit, thread an 11/16" LH jam nut onto each of the 90003050 rod ends (the longer ones). Then thread an 11/16" RH jam nut onto each of the 90003051 rod ends (the shorter ones). Thread the jam nuts all the way up the rod ends for now so you have enough room to make length adjustments.

The tie rod adjuster has both left-hand and right-hand threads. The grooved end of the adjuster has the left-hand threads (Figure 63). Apply anti-seize to the threads at each end of the tie rod adjuster.

Thread the longer tie rod into the end of the adjuster that has the groove. Then thread the shorter rod end into the opposite side.

Use the sight holes at each end of the tie rod adjusters to ensure you have sufficient thread engagement (Figure 63). You should be able to see at least one or two threads in the "window" for adequate engagement.



Figure 61

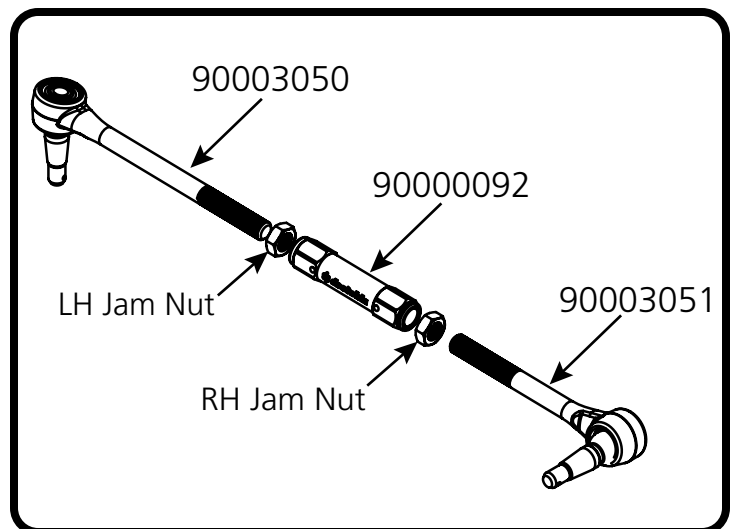

Figure 62

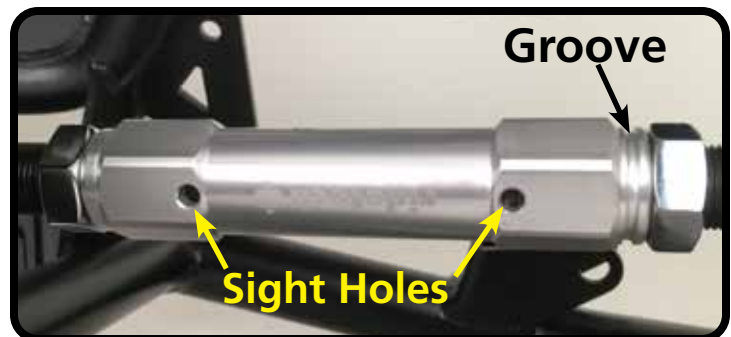

Figure 63

Tie Rod Installation

58. Insert the stud of the inner tie rod end into the mounting hole on the cradle (located just above the front lower control arm mount). See Figure 64.

The inner portion of the tie rod assembly is the end with the shorter rod end.

59. Insert the stud of the outer tie rod end into the hole on the steering arm (Figure 65).

The outer portion of the tie rod assembly is the end with the longer rod end and the grooved end of the adjuster.

60. Install the castle nut on each of the rod ends and torque to **40 ft-lbs**. Then install and bend the cotter pins (Figure 66).

It may be necessary to tighten the nut a bit more to line up the cotter pin holes.

Install the grease zerks in each of the rod ends if you have not already done so.

Repeat for the opposite side.

Do not forget to tighten the jam nuts once your tie rod length has been set.

Ensure all fasteners have been tightened/torqued.



Figure 64



Figure 65



Figure 66

Riv-Nut® Installation & Specs

1. Drill hole in frame using the SUPPLIED DRILL BIT, keeping the drill square with the metal.
2. We recommend installing (2) 3/8" flat washers between the bolt head and the lower anvil of the installation tool. Thread a Riv-nut® onto the supplied Tool. Thread the Riv-nut all the way onto the tool until it stops.
3. Insert the tool and Riv-nut® into the drilled hole 90° to the frame rail.
4. The tool requires (1) 9/16" & (1) 5/8" wrench. A ratchet can be used on the top of the tool.

KEEP THE TOOL AND RIV-NUT 90° TO THE SURFACE WHILE TIGHTENING

5. Place a 5/8" wrench on the lower hex of the tool. Use a wrench or ratchet on the top hex to tighten.
6. Hold the wrench in one position and turn the TOP HEX CLOCKWISE to engage the Riv-nut®. Keep turning the TOP WRENCH until you feel a positive stop and you can't turn the TOP WRENCH anymore.
7. Break the tool loose by turning the TOP HEX counterclockwise and thread the tool out of the Riv-nut®.

THE DATA BELOW ILLUSTRATES THE STRENGTH OF THE RIV-NUT®

RIVNUT® Fastener Engineering Data

Upset Load (lbs.)		
RIVNUT * Size	Steel	
	Min. Grip	Max. Grip
3/8-16	4965	5325

Fig. 1

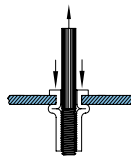

Ultimate thread strength (lbs.)		
RIVNUT * Size	Steel	
	Min. Grip	Max. Grip
3/8-16	11500	10450

Fig. 2

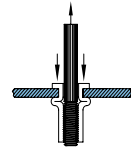

Ultimate tensile strength (lbs.)	
RIVNUT * Size	Steel
3/8-16	3900

Fig. 3

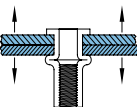

**Single-Shear Strength of 3/8" Grade 5 Bolt:
3,975.8 lbs**

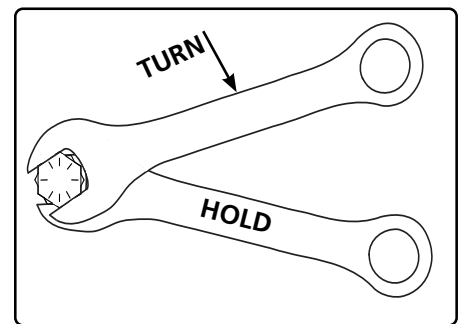
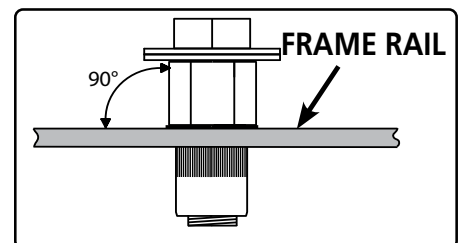
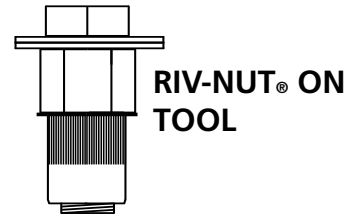
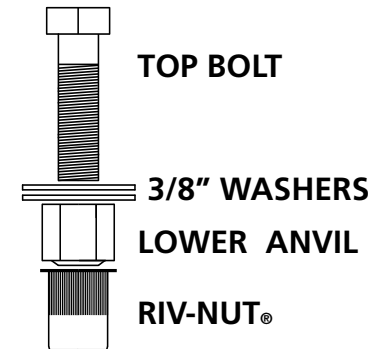



TORQUE & ALIGNMENT SPECIFICATIONS



LOCATION	TORQUE SPEC
3/8"-16 Cradle Mounting Bolts	33 ft-lbs
5/8"-18 Front Cradle Bolts	162 ft-lbs
1/2"-13 Upper Control Arm Bolts	75 ft-lbs
M14-2.0 Differential Mount Bolts	100 ft-lbs
3/8"-16 Support Sleeve Bolts	32 ft-lbs
1/2"-13 Lower Control Arm Bolts	75 ft-lbs
M12-1.5 Hub To Spindle Bolts	99 ft-lbs
1/2"-13 Steering Arm Bolts	93 ft-lbs
Upper Ball Joint Castle Nut	50 ft-lbs
Lower Ball Joint Castle Nut	65 ft-lbs
Inner/Outer Tie Rod Castle Nuts	40 ft-lbs
5/8"-18 Upper Shock Mount	162 ft-lbs
1/2"-13 Lower Shock Mount	75 ft-lbs

Suggested Alignment Specs For Street Driving

Camber: -.5 to -1 Degrees

Toe: .25 Degrees Total Toe In



CAMBER LOCKOUT PLATE POSITIONS

(As Viewed From The Front Of The Cradle)

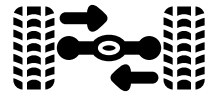

+ = Bolt Location		
Degrees (-)	Passenger	Driver
0.25		
0.5		
1		
1.25		
1.5		
1.75		
2		
2.5		



PINION ADAPTER SELECTION

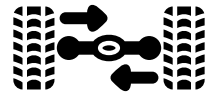

1. This kit requires a pinion flange to U-joint adapter to mate the S550 differential to the shortened drive shaft. You must select an adapter prior to determining the modified length of your drive shaft. These adapters are available from several vendors. We chose the Sonnax T35-ALFY-10 to use with the Ford Performance center sections used in our builds. Several options are available to accommodate various pinion output flange measurements.

2. Before purchasing a pinion adapter, record the measurements below from your pinion output flange to ensure you are purchasing a compatible part. Don't forget to also consider the U-Joint Series you will be using.

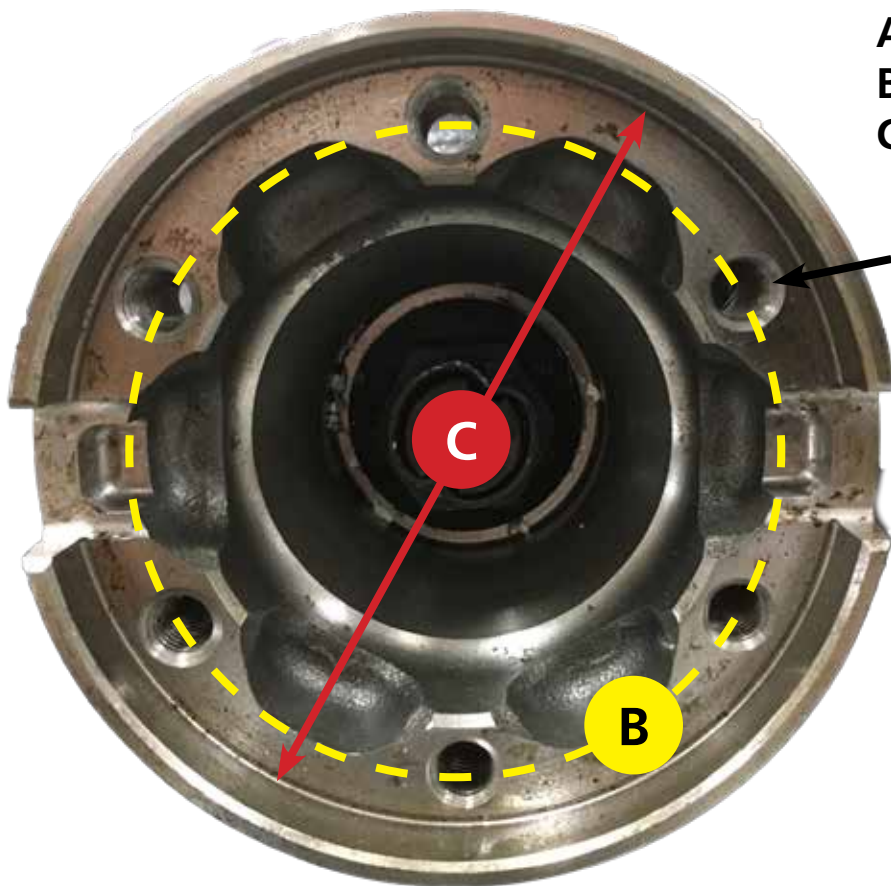

- A. Bolt Hole Diameter
- B. Bolt Circle Diameter
- C. Pilot Diameter



DRIVE LINE MODIFICATIONS

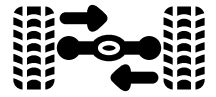

1. Before determining the new length of your drive shaft, you must first have selected and installed your pinion flange to U-joint adapter (see page 34). The differential must be mounted in the cradle in the car to obtain an accurate measurement. These adapters are available from numerous vendors and will be specific to your particular pinion flange and U-joint combination.
2. With the adapter installed, measure from the center of the differential U-joint to the center of the U-joint on the slip yoke at the transmission. See dimension "X" in the illustration below. This is the measurement the drive line shop will need to produce or modify your drive shaft.
3. Once this installation is complete, you might consider checking your drive line angles, especially if you have recently completed an engine/transmission swap. We did not observe any significant changes to pinion angle on any of our installs, but this is a good opportunity to give it a quick check. With the rear differential now in a fixed position, your only adjustment option is to shim the rear of the transmission either up or down.

