

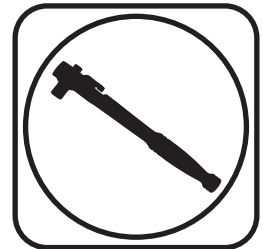

### Part # 12146110 - 1994-2004 Mustang HQ CoilOvers

#### Recommended Tools



## 1994-2004 Mustang HQ Series Rear Coil-Overs Installation Instructions

#### Table of contents

- Page 2-3..... Included Components
- Page 4..... Getting Started and Disassembly
- Page 5..... Body Prep and Lower Mount Installation
- Page 6..... CoilOver Assembly
- Page 7..... CoilOver Installation
- Page 8-9..... Shock Tuning Guide





### Major Components .....In the box

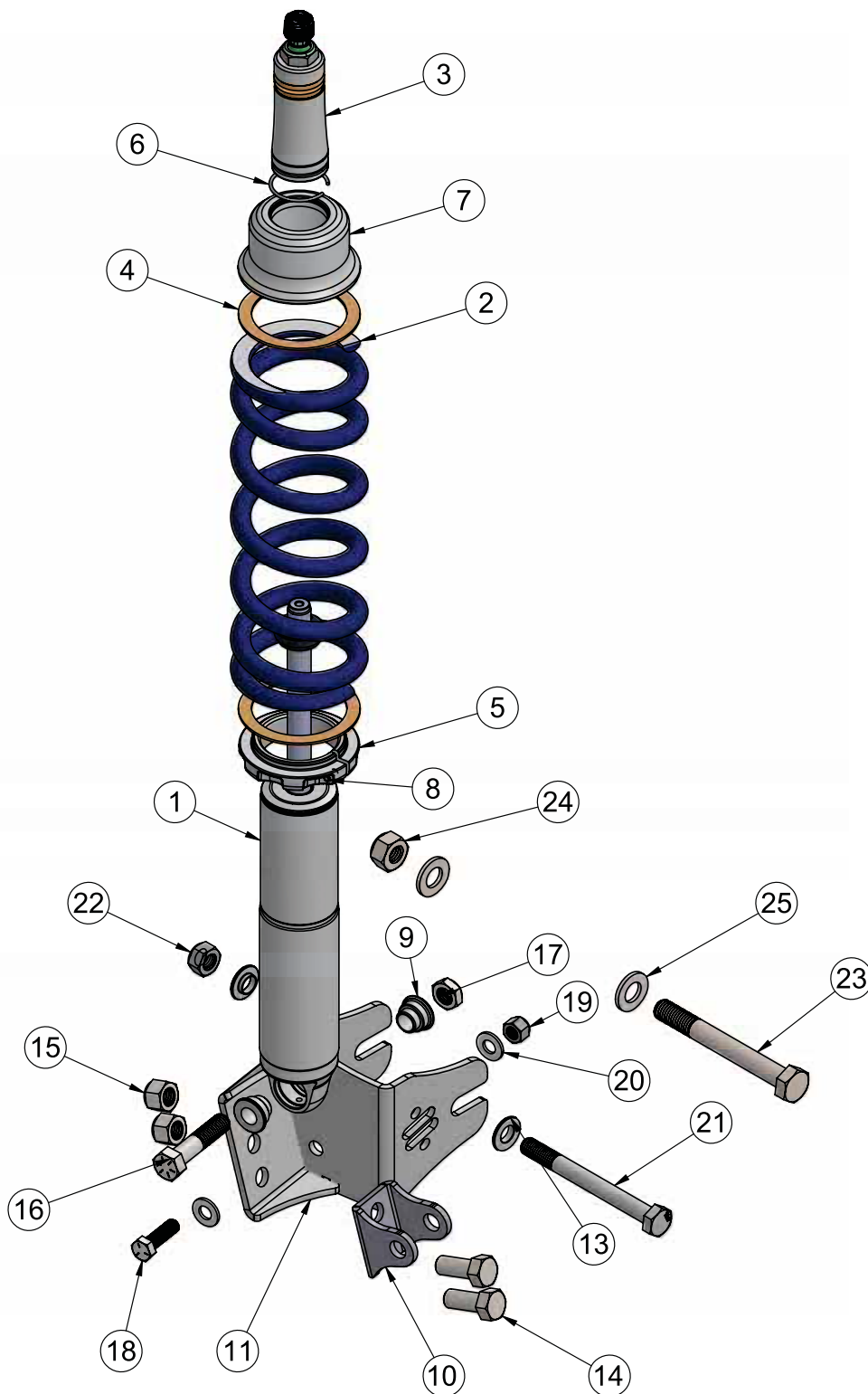



### Major Components .....In the box

Item	Part #	Description	QTY
1	982-10-805	5.2" Stroke HQ Series Shock	2
2	59100125	CoilSpring	2
3	90002049 Kit	90009989 - 2.75" Stud Top	2
3	90002049 Kit	90002313 - 2.75" Stud Top Base	2
3	90002049 Kit	90001904 - Lower Delrin Half	2
3	90002049 Kit	90001903 - Upper Delrin Ball Half	2
3	90002049 Kit	90001902 - Upper Delrin Ball Cap	2
3	90002049 Kit	99562003 - 9/16-18" Nylok Nut	2
4	70010828	Delrin Washer	4
5	234-15-200	CoilSpring Mount Locking Ring	2
6	038-06-001-A	CoilSpring Mount Retaining Ring	2
7	90001373	CoilSpring Mount 1.5" Drop Cap	2
8	99050001	CoilSpring Mount Locking Ring Clamp Bolt	2
9	90002043	Shock Bearing Spacer - 1/2" ID	4
10	90002158	2 Hole Lower Shock Mount	2
11	90002467	Driver Lower Shock Mount-Axle Mount	1
11	90002468	Passenger Lower Shock Mount-Axle Mount (Not Shown)	1
13	90001372	14mm to 12mm T-Bushing	4
14	99501019	1/2"-13 x 1 1/4" Hex Bolt (2 Hole Mount to Axle Mount)	4
15	99502001	1/2"-13 Nylok Nut (2 Hole Mount to Axle Mount)	6
16	99501010	1/2"-20 x 2 1/4" Hex Bolt (Lower Shock to Mount)	2
17	99502003	1/2"-20 <b>THIN</b> Nylok Nut (Lower Shock to Mount)	2
18	99371004	3/8"-16 x 1 1/4" Hex Bolt (Lower Mount to Axle)	2
19	99372002	3/8"-16 Nylok Nut (Lower Mount to Axle)	2
20	99373003	3/8" SAE Flat Washer (Lower Mount to Axle)	4
21	99121013	M12-1.75 x 120mm Hex Bolt (Axle Mount to Axle)	2
22	99122001	M12-1.75 Nylok Nut (Axle Mount to Axle)	2
23	99141005	M14-2.0 x 120mm Hex Bolt (Axle Mount to Axle)	2
24	99142002	M14-2.0 Nylok Nut (Axle Mount to Axle)	2
25	99143001	M14 Flat Washer (Axle Mount to Axle)	4
	90001995	Bearing Snap Ring (Installed in Shock Body)	4
	90001994	5/8" ID Bearing (Installed in Shock Body)	2



### Getting Started and Disassembly

Congratulations on your purchase of the Ridetech Mustang CoilOver System. This system has been designed to give your Mustang excellent handling along with a lifetime of enjoyment. The CoilOver System provides flexibility that can not be achieved with Conventional CoilSprings.

#### **This CoilOver System is Designed to replace the factory Shock and CoilSprings.**

1. The rear OEM Shocks, Pinion Snubber and Mount, CoilSpring, and Horizontal Kicker Shock will need to be removed from the Rear of the car.
2. Raise the vehicle and support it by the frame allowing the suspension to hang freely. Be sure the rear differential will be able to swing down to get the rear springs out.
3. Place a jack under the center of the rear differential and raise it up to the point the jack is touching the rear differential. Be sure that the car is high enough that you will be able to lower the jack supporting the rear differential to remove the Coilsprings.
4. The Nut will need to be removed from the top of the shock. The top of the shock is either locked in the trunk behind the side covers, or in the hatch under a plastic cover located by the wheel tub.
5. Unbolt the lower shock from the shock mounting bracket and unbolt the shock bracket from the differential.
6. Lower the jack slowly to remove the tension of the Coilspring. Pay attention to the brake line and ABS(if equipped) wire that you don't damage them when lowering the differential
7. With the springs loose, remove the from the car.
8. Remove the OEM Pinion Snubber and mount from the rear body.

To get Started refer to the page 5.

**NOTE: THE LOWER CONTROL ARM BOLT SIZE CAN VARY DEPENDING ON THE YEAR OF CAR YOU ARE INSTALLING THE COILOVERS ON. WE HAVE INCLUDED 12MM & 14MM FOR THIS REASON. YOU WILL NEED TO DETERMINE THE CORRECT SIZE HARDWARE FOR YOUR INSTALLATION.**



### Body Prep and Lower Mount Installation

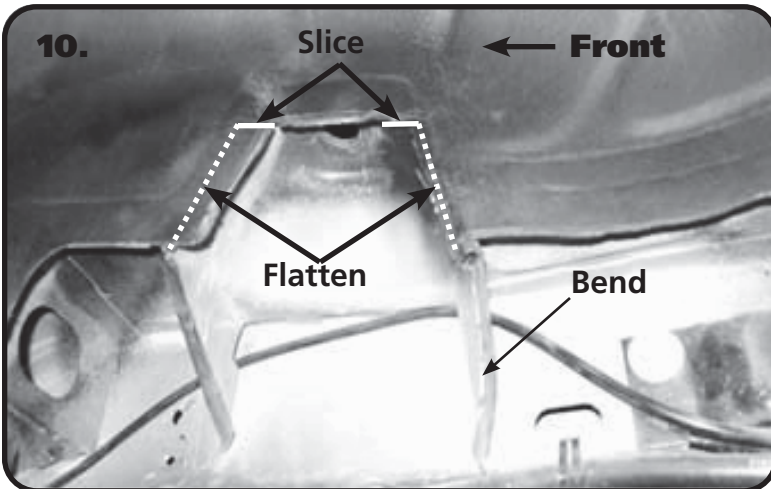

**10.** Illustration 10 shows the modifications that need to be done to the Shock opening for CoilOver clearance. The rear has been done in the picture to show what the end result should look like. Slice the sheet metal at the top of the opening forward and backward even with the top of the opening. With the sheet metal sliced, bend the pinch weld inward until it is flat against the front and back of the opening. Bend the rear brace back to clear the Air Spring on the Shockwave.

**Repeat on both sides of the car.**

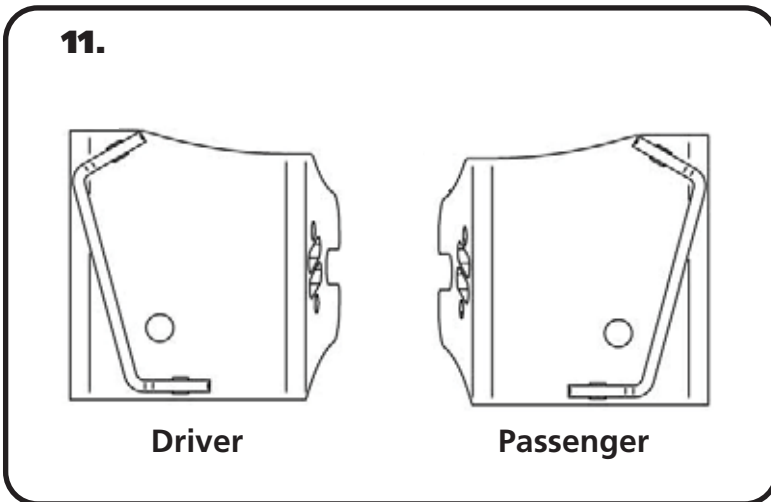

**11.** If you haven't done so already, remove the OEM Lower Shock Mount from the axle. If you are installing StrongArms, now is a great time to do the Lower. The size of your control arm bolts will determine the proper steps for mounting the lower shock mount. If your car has a 14mm lower control arm bolt, remove it and replace it with the M14-2.0 x 120mm bolt supplied in the kit. You will need to install a M14 flat washer on the bolt before installing it. Install the 14mm bolt/washer and install a M14 flat washer & M14-2.0 nylok nut on the bolt. Leave the bolt loose for now. If your car has a 12mm bolt, install one of the T-Bushings on the M12-1.75 x 120mm bolt with the large OD against the bolt head. Insert the 12mm bolt/t-bushing. Install a 2nd T-Bushing, with the Large OD to the nut, on the threads sticking through the axle mount, followed by a M12-1.75 nylok nut. Leave the nut loose for now.



**Illustration 11** shows the New Lower Shock Mount viewed from the rear.

**12.** Slide the Lower Shock mount on to the Axle Mount. The Shock Mount wraps around the OEM Control Arm mount. The Slots on the side of the Mount slide on the Lower Control Arm Mounting Bolt. Install (1) 3/8-16 x 1 1/4" bolt (Threads pointing forward) through the hole in the Shock Mount and Lower Control Arm Mount. Install a 3/8" Flat Washer and 3/8" Nylok Nut on the Bolt and tighten. Tighten the Lower Control Arm Bolt.



### CoilOver Assembly

13.

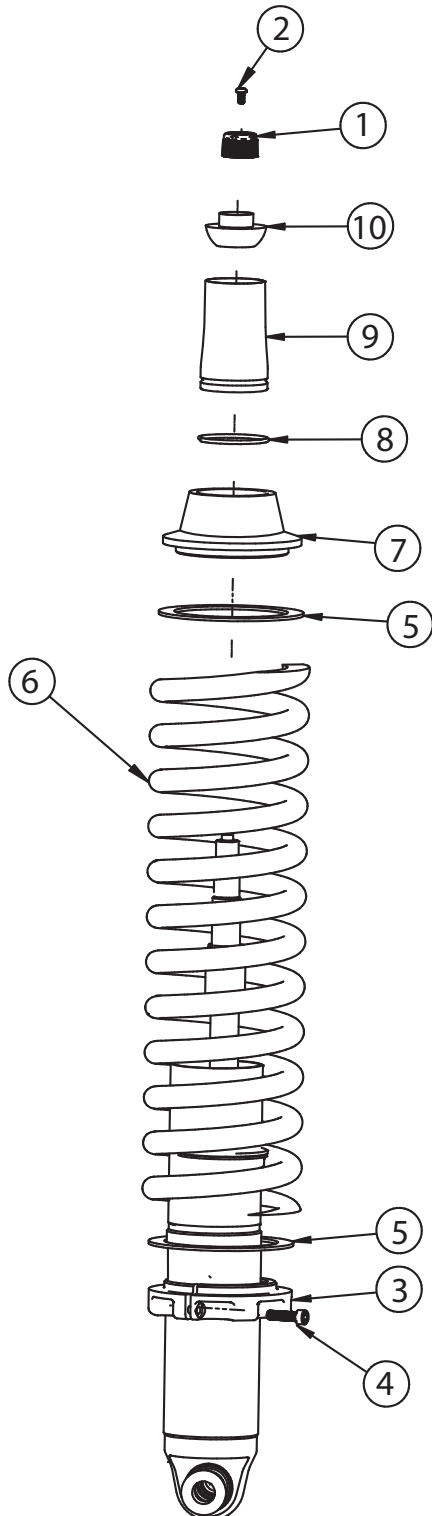

13. To Assemble the CoilOver you need to:

- a. Remove Screw (2) from center of Adjustment Knob (1) and remove Adjustment Knob.
- b. Remove Nylok Nut, Delrin Upper Cap, Delrin Upper and Lower Balls, along with the base from the CoilOver stud.
- c. Thread Adjuster Nut (3) onto the CoilOver body. Once it is threaded on the shock body, lightly thread in the locking screw (4) into the Adjuster Nut.
- d. Install a Delrin Spring Washer (5) onto the Adjuster Nut.
- e. Slide the CoilSpring (6) onto the CoilOver.
- f. Install another Delrin Spring Washer (5) on top of the CoilSpring.
- g. Install the Upper CoilSpring Plate (7) onto the CoilSpring.
- h. Install the CoilSpring Retaining Ring (8) onto the Stud Top Base (9). It fits into the groove in the base.
- i. Slide the Stud Top Base onto the shock until it bottoms out on the stud. It may be necessary to thread the Adjuster Nut down the shock body (to lower the spring) if the base will not slide all the way down onto the stud.
- j. Slide the Lower Delrin Ball (10) (it has the collar sticking up around the center hole) on to the Stud Top.

Repeat on second CoilOver.



### CoilOver Installation

14.

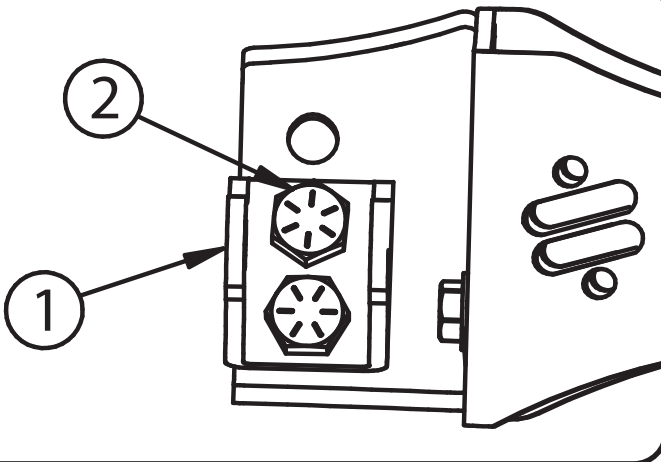

14. Attach the 2 Hole Lower Shock Mount(1) to the Main Mount using  $\frac{1}{2}$ " x  $1 \frac{1}{4}$ " bolts (2) with a Nylok nut on the back side. The Mount bolts to the 2 lower holes. If a higher ride height is desired, the top 2 holes can be used.

15.

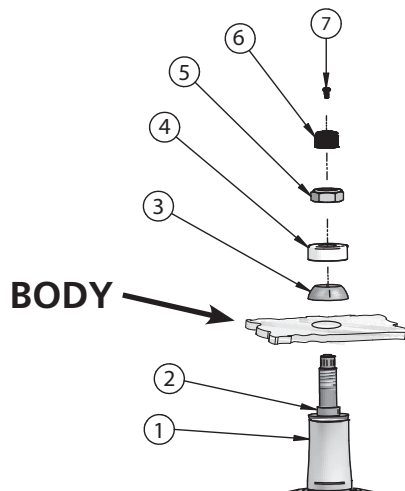

15. With the CoilOver(1) assembled, it is time to bolt them into the car. Insert to CoilOver Stud Top through the factory hole in the frame. Install the Upper Delrin Ball(2) onto the shock stud with the flat side facing the frame. Next, Install the Delrin Ball cap (3) onto the shock stud with the Concave side facing the Upper Delrin ball. Install the Nylok Nut(4) onto the shock stud and lightly tighten. The needs to be some resistance on the ball but not tight enough that it will not rotate freely. Reinstall the adjuster knob(5) using the screw (6) that was removed during step 10.

16.

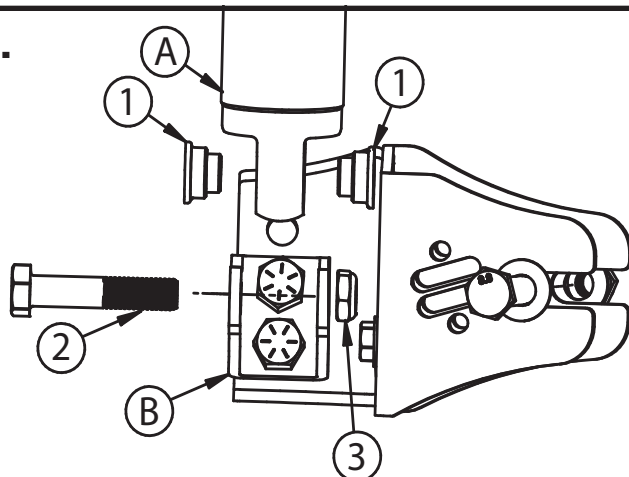

16. Install the CoilOver(A) in the Lower Shock Mount(B) using a 90002043 Spacer(2) inserted into each side of the Shock bearing. Slide the shock into the stock mounting location. It may be necessary to use the jack and raise the differential to align the mounting holes. With the mounting holes aligned, insert a  $\frac{1}{2}$ "-20 x  $2 \frac{1}{4}$ " Bolt through the Mount and Shock. Install a  $\frac{1}{2}$ "-20 **THIN** Nylok Nut (3) on the Bolt and Tighten.

**Repeat on the opposite side.**



# TUNING GUIDE

## SINGLE-ADJUSTABLE SHOCKS



### The Basics...

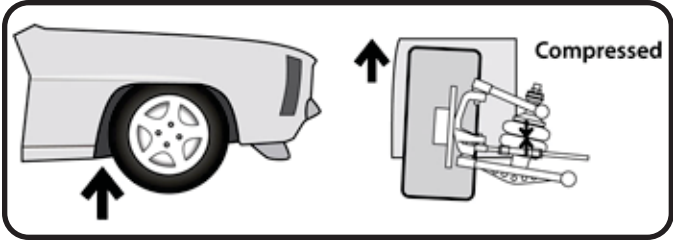

#### COMPRESSION

This typically occurs when you hit a bump in the road. The bump forces the wheel/tire/suspension assembly to "compress" or move upwards into the car.

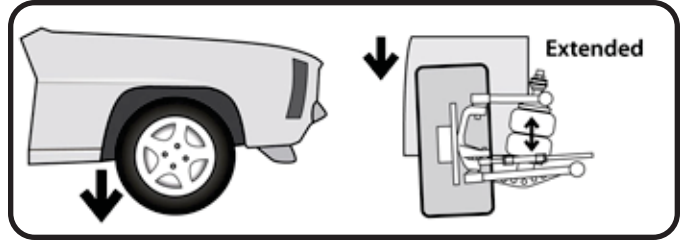

#### REBOUND

Rebound is the opposite of compression. This occurs when the wheel/tire/suspension assembly falls into a pothole, or simply "rebounds" from being compressed.

### Where Are The Knobs?

#### HQ Series Shocks

- The adjustment knob is located on the top of the shock, either protruding from the side of the eyelet, or atop the stud.
- This knob provides rebound adjustment only.

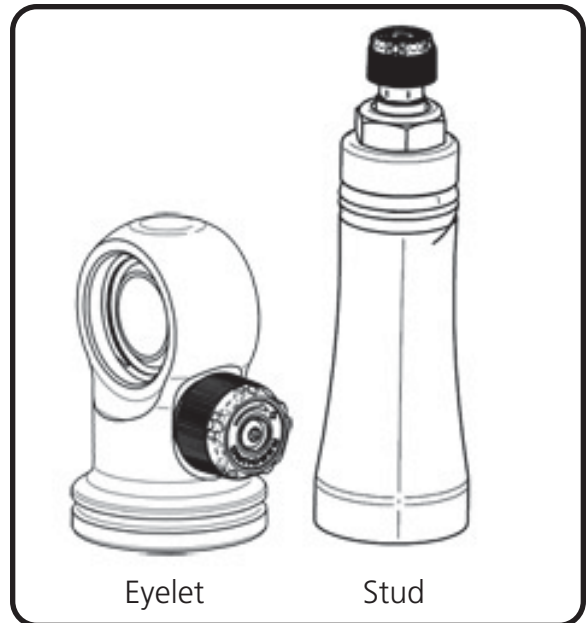

### Knob Function

Counterclockwise

=  
Softer

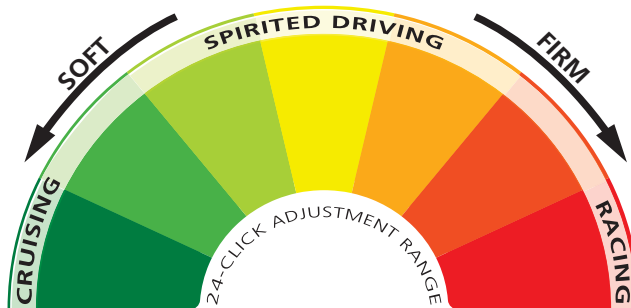

Clockwise

=  
Firmer





# TUNING GUIDE

## SINGLE-ADJUSTABLE SHOCKS



### Initial Rebound Setting

**NOTE:** Before jumping straight to a middle-of-the-road shock setting, we recommend you experience the full range of adjustment potential of your new shocks by first driving your vehicle at both the “full stiff” and “full soft” settings. Understanding how your shocks behave at these extremes will provide recognizable reference points as you attempt to dial in your settings.

1. Begin by setting your shocks to the “full stiff”, or minimal rebound position. You do this by turning the adjustment knob clockwise until it stops.

2. Now turn the adjustment knob counterclockwise 12 clicks. This is the approximate center of the adjustment range.

3. Take the vehicle for a test drive. Try to determine if you are experiencing any of the unwanted behaviors found at the extremes of the adjustment range. If you are satisfied with the ride quality and handling, you’re all set. Enjoy the ride!

4. If the vehicle feels too “floaty” or soft, turn the knob a few clicks clockwise to increase the damping effect.

If the ride quality is still too harsh or stiff, turn the knob a few more clicks counterclockwise to decrease the damping effect.

5. Take the vehicle for another test drive. If necessary, repeat the steps above until your desired optimal ride quality has been achieved.



### General Guidelines

- The rear shocks typically have the most influence on ride quality. This is due to your seating position being closer to the rear than the front.
- Adjustments to the front shocks will generally require 3-4 clicks in any direction to be noticeable, while adjustments to the rear shocks may only require 1-2 clicks to be felt.
- Don't be afraid to turn the knobs and experience the full adjustment range. You are not going to hurt anything and you can always go back if you adjust too far one way or the other.