

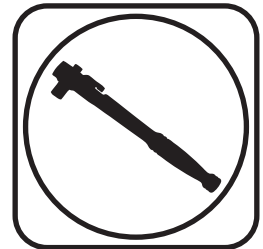

Part # 12270701 - 2015-up Mustang HQ Series Shocks



Recommended Tools



2015-up Mustang HQ Series Rear Shocks Installation Instructions

Table of contents

Page	2.....	Components & Shock Installation
Page	3.....	Shock Installation & Adjustment

THIS KIT IS DESIGNED TO BE USED WITH RIDETECH COOLRIDE AIR SPRING KIT # 12274099.

THIS SHOCK KIT WILL NOT FIT THE GT350!!





HQ Series Smooth Body Shocks

Major ComponentsIn the box

Part #	Description	QTY
986-10-081	6.65" Stroke Shock	2
70011139	5/8" ID Shock Bushing (Installed in Shock)	2
90002068	Wide Trunnion (Installed in Shock)	2
70012354	Upper Mounting Spacers	4
99372006	3/8"-24 Thin Jam Nut	4
99311022	5/16"-18 x 1 3/4" Hex Bolt	4
99313002	5/16" Flat Washer	8
99312002	5/16"-18 Nylok Nut	4

Shock Installation

This shock kit should be installed by the same time as the rear CoolRide Kit.

Refer to the Factory Service Manual for disassembly and Coilspring removal instructions.

1. Remove the Shocks and the OEM Upper Shock Mount from the Car.
2. Disconnect the Sway Bar Linkage from the Control Arms. These will be reinstalled.

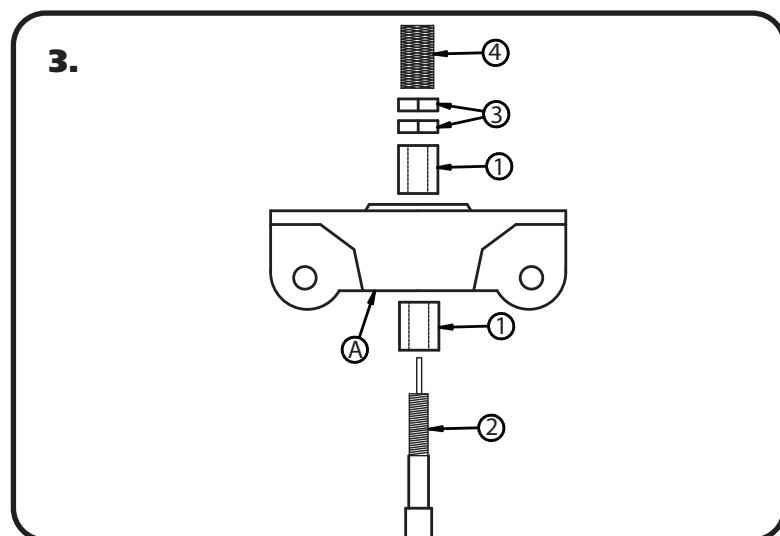

3. The HQ Series Shock bolts into the stock location using the OEM upper mount(A). Install an Aluminum Spacer(1) on the Shock Shaft(2). Insert the Shock Shaft into the OEM shock mount. Install a 2nd Aluminum Spacer(1) onto the shock shaft. Thread a 3/8"-24 Lock Nut(3) onto the Shock Shaft and tighten. Install a 2nd 3/8"-24 Lock Nut on the shock shaft and tighten against the 1st lock nut. Installed the Adjuster Knob(4). Install the Assembly into the OEM location. Repeat for both sides. Torque the OEM Bolt to 65ftlbs.



Shock Installation and Adjustment

2.

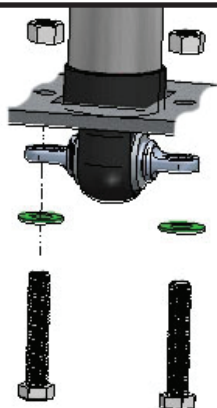

2. Attach the Trunnion to the OEM Control arm using the supplied Hardware. It may be necessary to rotate the Trunnion to get it in the correct position. This can be done by sticking a screwdriver in one of the slots and spinning the trunnion in the shock bushing. Torque the hardware to 17ftlbs. Do this for both sides. Reattached the sway bar linkage.

The CoolRide kit should already be installed, if not, do it at this time and lower the rear of the car to the ground.

Shock adjustment 101- Single Adjustable

Rebound Adjustment:

How to adjust your new shocks

The rebound adjustment knob is located on the top of the shock absorber protruding from the eyelet or stud top. You must first begin at the ZERO setting, then set the shock to a street setting of 12 or handling setting of 8.

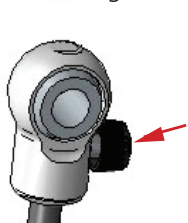

-Begin with the shocks adjusted to the ZERO rebound position (full stiff). Do this by rotating the rebound adjuster knob clockwise until it stops.



-Now turn the rebound adjuster knob counter clockwise 12 clicks. This sets the shock at 12 for a street setting. If you are after a handling setting only go 8 clicks.

Take the vehicle for a test drive.



-if you are satisfied with the ride quality, do not do anything, you are set!

-if the vehicle is too soft increase the damping effect by rotating the rebound knob clockwise 3 additional clicks.



-If the vehicle is too stiff rotate the rebound adjustment knob counter clock wise 2 clicks and you are set!

Take the vehicle for another test drive and repeat the above steps until the ride quality is satisfactory.

Note:

One end of the vehicle will likely reach the desired setting before the other end. If this happens stop adjusting the satisfied end and keep adjusting the unsatisfied end until the overall ride quality is satisfactory.