



Part # 12280201 - 1961-1965 Ford Falcon HQ Series CoilOver System

Recommended Tools

Front Components:

12289599 Front TruTurn Kit
 12283510 Front CoilOvers
 12289100 Front SwayBar

Rear Components:

12287199 Rear 4Link System
 12286510 Rear Coilover Instructions

Miscellaneous Components:

85000000 Spanner Wrench

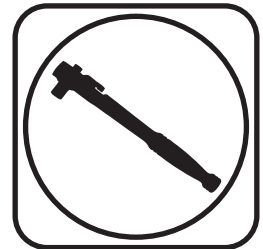

1961-1965 Ford Falcon Coilover Installation Instructions

Table of contents

Pages 2-19..... TruTurn Front Suspension
 Pages 20-26..... Front CoilOvers
 Pages 27-31..... Front SwayBar
 Pages 32-51..... Rear 4-Link
 Pages 52-54..... Rear CoilOvers
 Pages 55..... Shock Adjustment

Mini-Starter required to clear TruTurn Centerlink Adapter (not Included).

The OEM Front Brakes will not work with this kit. (See Page 7 for details)





Part # 12289599 - 1961-1965 Ford Falcon Front TruTurn System



Recommended Tools

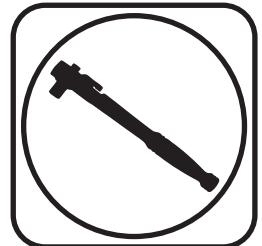

1961-1965 Ford Falcon TruTurn System Installation Instructions

Table of contents

Page 3.....	Major Components
Page 4.....	Upper Control Arm Components
Page 5.....	Lower Control Arm Components
Page 6.....	TruTurn Steering Components
Page 7.....	Hardware & Getting Started
Page 8.....	Installing Strut Rod Adapter
Page 9-11.....	Installing Control Arms
Page 12.....	Spindle Installation
Page 12-13.....	Installing Idler Arm
Page 14.....	Installing Pitman Arm & Centerlink
Page 15-16.....	Centerlink Adapter Installation
Page 17.....	Steering Arm & Stop Installation
Page 18-19.....	Tie-Rod Assembly and Installation

Mini-Starter required to clear TruTurn Centerlink Adapter (not Included).

The OEM Front Brakes will not work with this kit. (See Page 7 for details)



Major Components AssembledIn the box

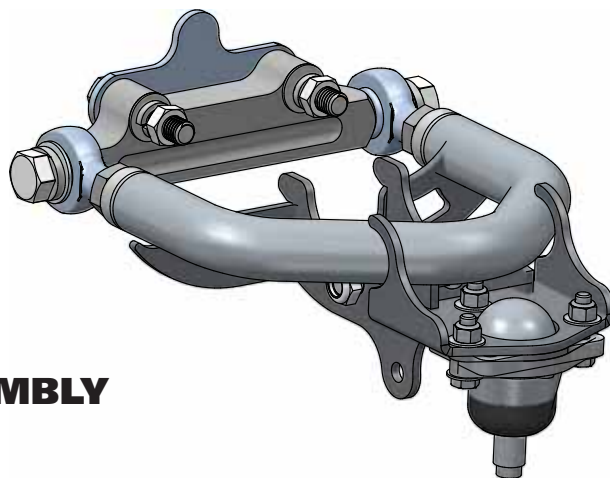

DRIVER UPPER CONTROL ARM ASSEMBLY

Exploded View on Page 4

DRIVER LOWER CONTROL ARM ASSEMBLY

Exploded View on Page 5

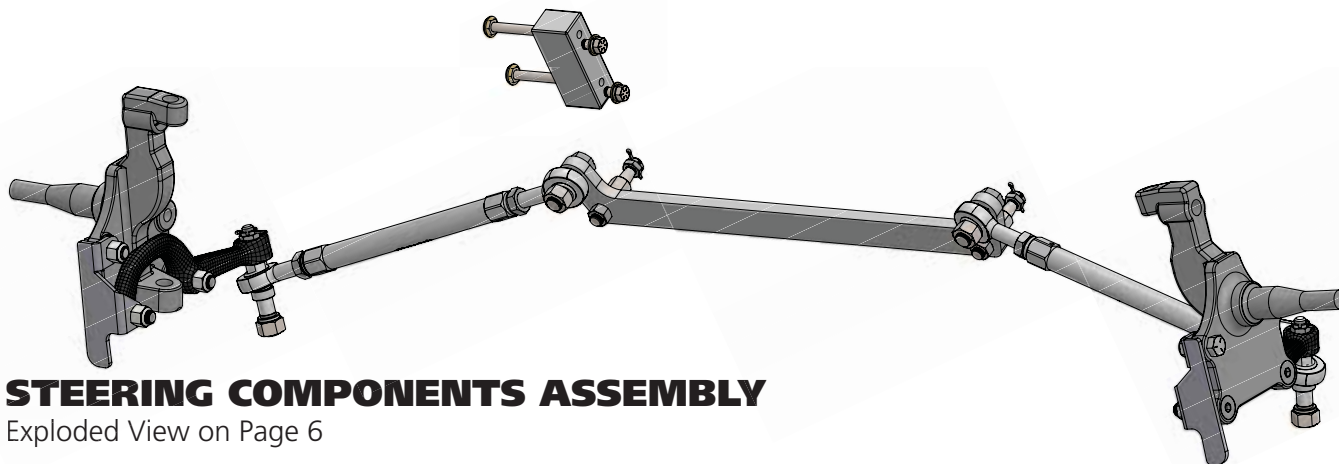
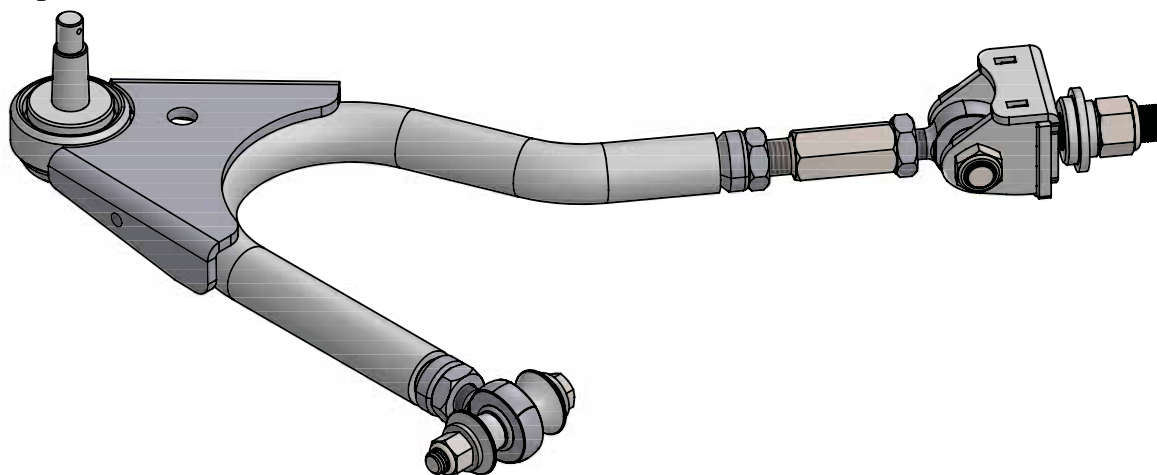

STEERING COMPONENTS ASSEMBLY

Exploded View on Page 6



Upper Control Arm ComponentsIn the box

Item #	Part Number	Description	QTY
1	90002339	Driver Upper Control Arm (Shown)	1
1	90002340	Passenger Upper Control Arm	1
2	90001589	Heim End	4
3	90009967	Upper Cross Shaft	2
4	70010866	Ball joint Assembly - Proforged # 101-10083	2
5	90002633	Ball joint Spacer	2
6	90002341	3/16" Alignment Shim	2
7	99621002	5/18"-18 x 1 3/4" Hex Bolt	4
8	99623001	5/8" SAE Flat Washer	4
9	99623002	5/8" Split Lock Washer	4
10	99311002	5/16"-18 x 1 1/4" Hex Bolt	6
11	99312003	5/16"-18 Nylok Nut	6
12	99313002	5/16" SAE Flat Washer	12
13	90002067	Shock Bearing Spacers	4

Driver Side Shown

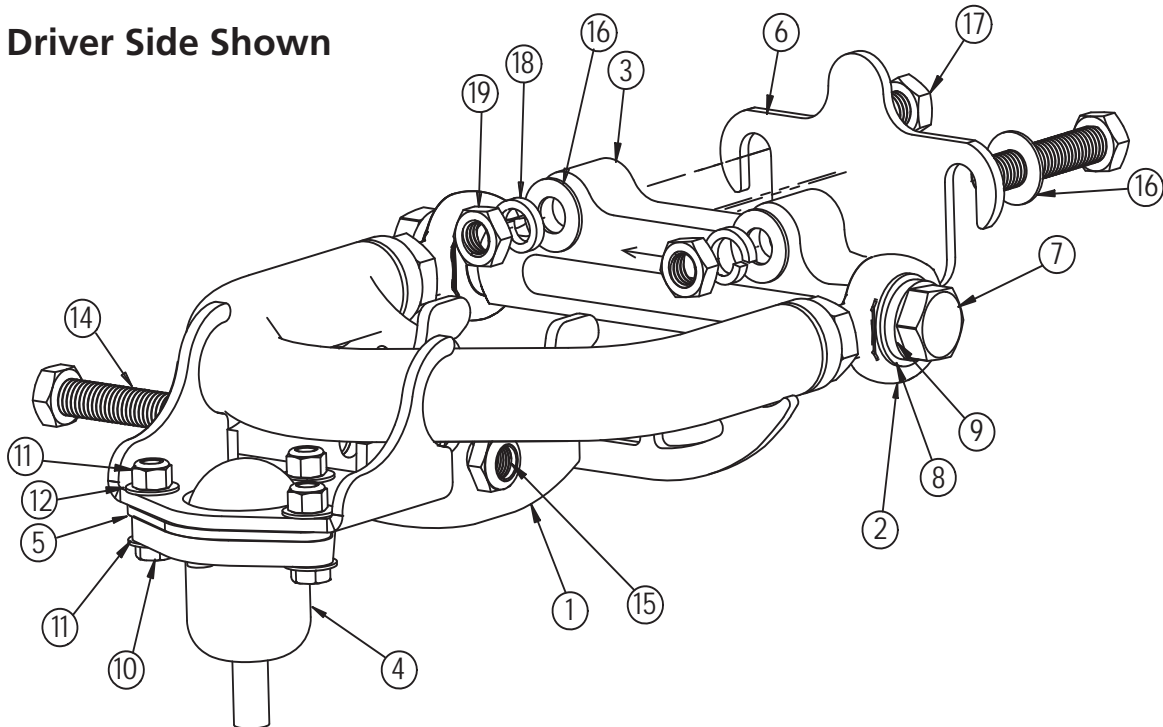

NOTE: DISCARD THE BALL JOINT NUT INCLUDED WITH THE BALL JOINT KIT. A NEW BALL JOINT NUT IS SUPPLIED IN THE HARDWARE KIT.



Lower Control Arm ComponentsIn the box

Item #	Part Number	Description	QTY
20	90003221	Driver Lower Control Arm (Shown)	1
21	90003222	Passenger Lower Control Arm	1
22	90003223	Strut Rod Frame Bracket Assembly	2
23	90003224	Frame T-Bushing	2
24	90001589	3/4" -16 x 5/8" Bolt Heim End - RH	2
25	90001591	3/4" -16 x 5/8" Bolt Heim End - LH	2
26	99752004	3/4" -16 Jam Nut - RH	4
27	99752006	3/4" -16 Jam Nut - LH	2
28	90002338	Frame Heim Spacer - 1/2" ID x 1.00" Long	4
29	90003225	Strut Rod Bracket Heim Spacer - 5/8" ID x .320" Long	4
30	90002582	Heim End Double Adjuster	2
31	90000898	Lower Ball joint - Proforged # 101-10013	2

Driver Side Shown

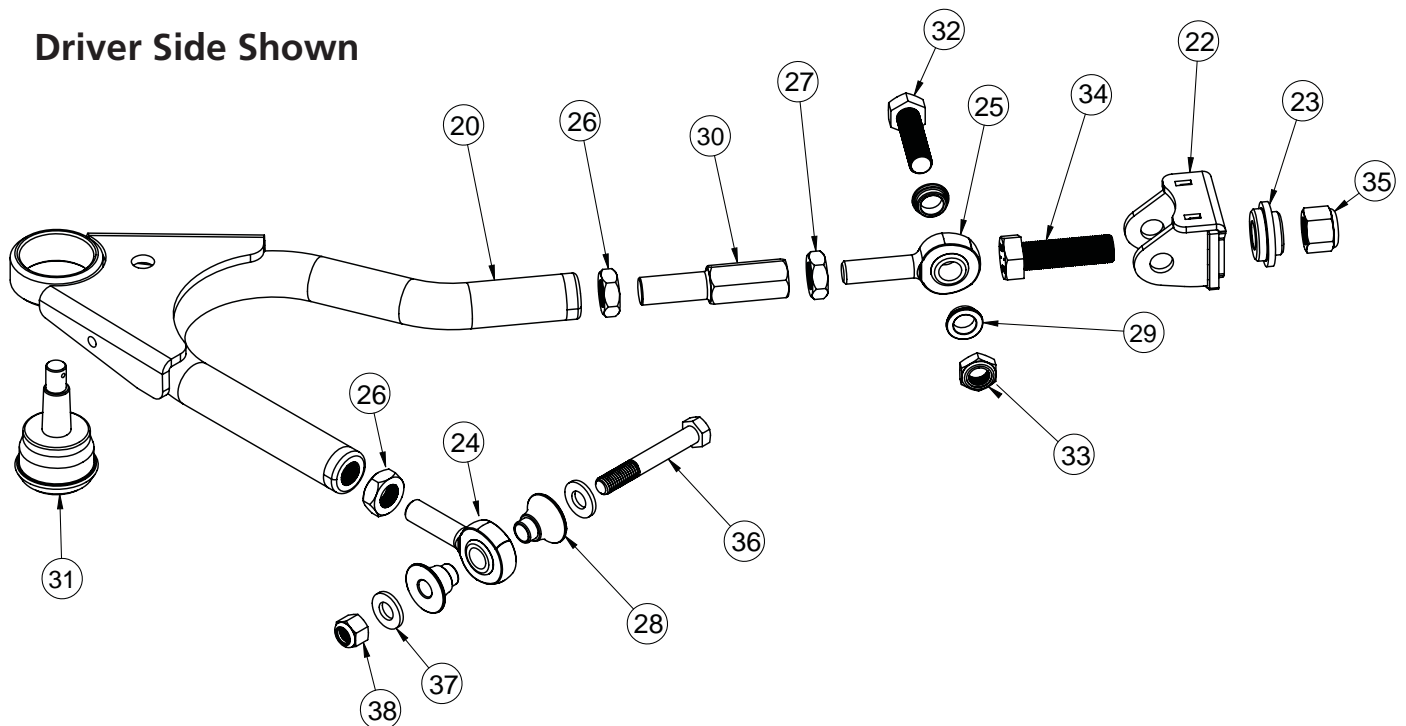



TruTurn Steering ComponentsIn the box

Item #	Part Number	Description	QTY
39	11009300	Ridetech Tall Spindle	1 pr
40	90002345	Drag Link Stud	2
41	90002351	Inner Tie Rod Stud	2
42	90002346	Tie-Rod Adjuster	2
43	90002347	Driver Steering Arm	1
44	90002348	Passenger Steering Arm	1
45	90002349	Bolt On Steering Stop - Driver	1
46	90002350	Bolt On Steering Stop - Passenger	1
47	90001582	Heim End - 5/8" -18 x 5/8" Bolt - LH Thread	2
48	90001590	Heim End - 5/8" -18 x 5/8" Bolt - RH Thread	2
49	90003219	Outer Tie Rod Stud	2
50	90003220	Outer Tie Rod Spacer - 5/8" ID x .375" BORGESON BOX ONLY	2
51	90002676	Outer Tie Rod Spacer - 5/8" ID x .125"	2
52	90003204	Centerlink Adapter	1
53	90003211	Offset Idler Mount - used with Borgeson Power Steering Box	1
54	90003205	Falcon Centerlink	1
55	90003206	Falcon Pitman Arm	1
56	90003207	Falcon Idler Arm Mount	1
57	90003055	Falcon/Mustang Idler Arm	1

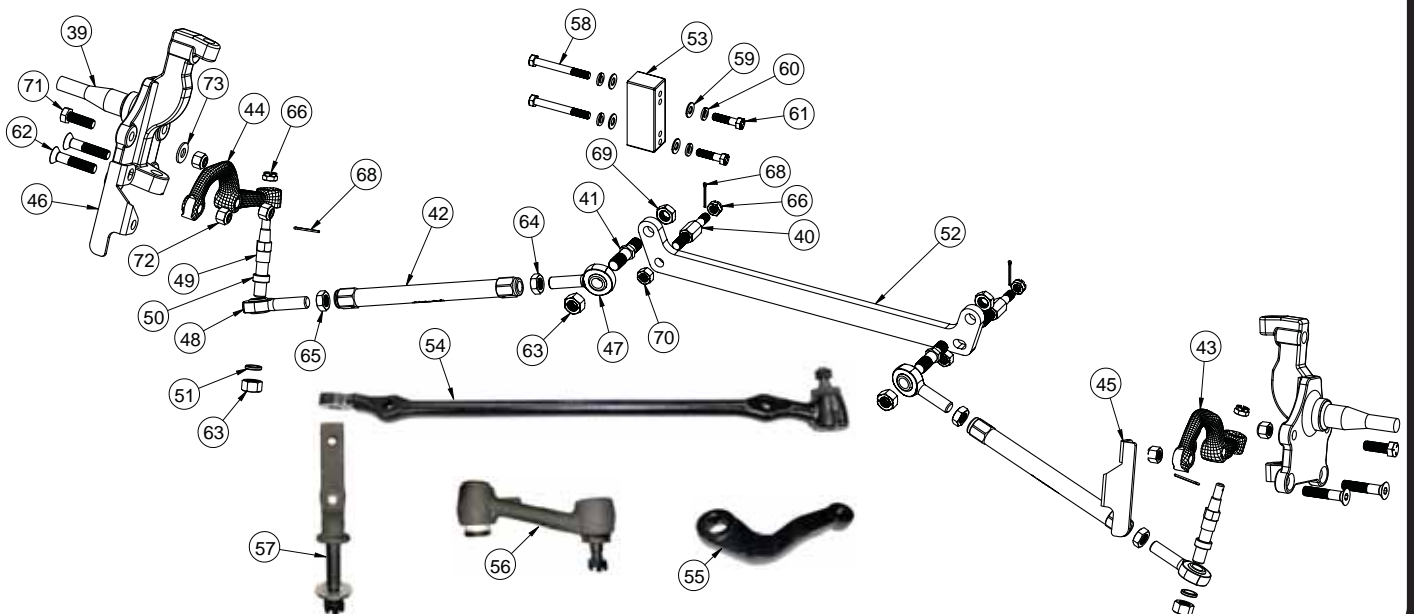



Hardware Shown in DiagramsKit# 99010151

ITEM #	Shock To Upper Control Arm		QTY	ITEM #	Idler Mounting Bracket To Mounting Block		QTY
14	99501005	1/2"-13 x 3 1/2" bolt GR8	2	59	99373002	3/8" SAE Flat Washer Gr8	2
15	99502009	1/2"-13 Nylok Nut GR8	2	60	99373006	3/8" Lock Washer	2
16	99503014	1/2" SAE Flat Washer GR8	4	61	99371007	3/8-16 X 1 1/2" Hex Bolt Gr8	2
Upper Control Arm To Car				Spindle To Steering Arm			
16	99503014	1/2" SAE Flat Washer GR8	8	62	99501054	1/2-20 X 2 1/2" Flat Head Socket Cap Screw	2
17	99501050	1/2"-13 x 2 1/2" bolt GR8	4	Steering Linkage			
18	99503015	1/2" SPLIT LOCK WASHER, GR8	4	63	99622003	5/8"-18 TOP LOCK NUT	4
19	99502021	1/2"-13 HEX Nut GR8	4	64	99800003	5/8"-18 RH Jam Nut	2
Upper Ball Joint To Spindle				65	99800002	5/8"-18 LH Jam Nut	2
	99502017	1/2"-20 Castle Nut	2	66	99432005	7/16"-20 Castle Nut	2
Heim End To Strut Rod Frame Bracket				67	99433002	7/16" SAE Flat Washer	2
32	99621031	5/8-18 X 2 1/4" Hex Bolt Gr8	2	68	99952002	3/32" Cotter Pin	2
33	99622006	5/8-18 Thin Nylok Nut	2	Draglink Adapter			
Strut Rod Frame Bracket To Car				66	99432005	7/16"-20 Castle Nut	2
34	99751005	3/4-16 X 2" Hex Bolt Gr8	2	67	99433002	7/16" SAE Flat Washer	4
35	99752001	3/4-16 Nylok Nut Gr8	2	68	99952002	3/32" Cotter Pin	2
Lower Control Arm To Car				69	99622005	5/8"-18 THIN mechanical locking nut	2
36	99501005	1/2-13 X 3 1/2" Bolt GR8	2	70	99502010	1/2"-20 Mechanical Locking Nut	2
37	99503001	1/2" SAE Flat Washer	4	Steering Stop			
38	99502001	1/2-13 Nylok Nut	2	71	99501053	1/2"-13 x 1 1/2" Hex Bolt GR8	2
Frame To Idler Mounting Block				72	99502009	1/2"-13 Nylok Nut GR8	2
58	99371067	3/8-16 X 3 1/4" Hex Bolt Gr8	2	73	99503014	1/2" SAE Flat Washer GR8	2
59	99373002	3/8" SAE Flat Washer Gr8	2				
60	99373006	3/8" Lock Washer	2				

Getting Started.....

Congratulations on your purchase of the Ridetech TruTurn System. This System has been designed to give your Falcon excellent handling along with a lifetime of enjoyment. Some of the key features of the TruTurn System: Ball joint angles have been optimized for the lowered ride height, eliminated rubber bushings to get rid of bushing deflection and provide free suspension movement through the entire range of travel. The geometry has been optimized for excellent handling, driveability and minimal bump steer.

Note: These control arms are designed for use with the Ridetech CoilOvers and the MuscleBar swaybar. **The factory shocks and springs or the factory sway bar will not fit these arms.**

Mini-Starter required to clear TruTurn Centerlink Adapter (not Included).

Ridetech offers a **V8 only** crossmember brace to help strengthen the front end of our Falcon. Part # **12289550**

Brake Kits

The Falcon TruTurn Suspension package uses a GM Spindle used on 67-69 F body, 64-72 A body, and 68-74 X body. Any brake kit designed for this spindle will work. It just **needs a 4 1/2" on 5 bolt pattern** to keep the same bolt pattern as the rear of the Falcon.

We collaborated with Baer and Wilwood to develop brake kits that work in harmony with our suspension. Depending on wheel size and your braking needs, both Wilwood and Baer have brake kits that will work with your car. Please visit our website to review options for your application.

1. Remove the entire front suspension from the car including the centerlink, idler arm, and pitman arm. Refer to a Factory Service Manual for the proper method. The control arms, spindles, and steering linkage will all be replaced with the TruTurn package.



Installing Strut Rod T-Bushing

2.

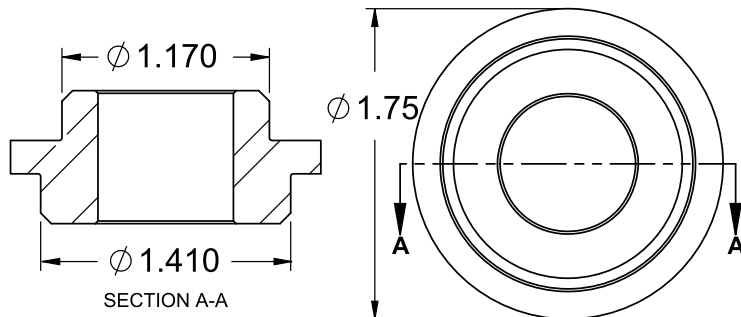

2. This kit includes a t-bushing for the strut rod bushing factory hole. The factory hole can be 2 different diameters depending on the year of the car. The size of your frame hole will determine which direction the t-bushing is installed.

3.



3. Test fit the t-bushing in your car's strut rod mount to help determine which direction it needs to be installed. The t-bushing is installed from the front side of the car.

4.



4. Insert 3/4\"-16 x 2\" bolt in the strut rod frame bracket. The head of the bolt needs to be on the side of the bracket with the 2 mounting ears.



Installing Lower Control Arm



5. With the 3/4"-16 x 2" bolt installed in the bracket, attach the bracket to the front heim of the control arm with the flat side of the bracket on the same side as the ball joint pin. The bracket is installed with a 5/8" ID x .320" spacer on each side of the heim. The spacers need to be installed with the small outside diameter against the heim end. Align the holes of the bracket with the through holes of the spacers and heim. Install a 5/8"-18 x 2 1/4" bolt through the aligned holes. Install a 5/18"-18 thin nylok nut on the threads of the bolt and torque to 45 ftlbs.



6. Insert the 3/4" bolt of the strut rod adapter bracket through the center hole of the t-bushing. The t-bushing and threads of the bolt should be to the front of the car.



7. Install a 3/4"-16 nylok nut on the threads of the bolt sticking through the t-bushing. Torque to 120 ftlbs.



Installing Lower & Upper Control Arm



8. Install the 2 aluminum spacers into the rod end that goes into the factory control arm pivot. Slip the control arm into the factory frame mount.



9. Align the factory holes with the control arm through hole. Install a 1/2" flat washer on a 1/2"-13 x 3 1/2" hex bolt. Insert the bolt/washer through the aligned holes. Install a 1/2" flat washer and 1/2"-13 nylok nut on the threads of the bolt. Torque to 75 ftlbs.



10. Bolt the upper StrongArm to the body using 1/2"-13 x 2 1/2" bolts, flat washers and lock washers. The ARROW points to the front of the vehicle. A shim is supplied and may need to be installed between the body and the arms to achieve proper alignment. The arms are preset at the factory so the alignment should be close, but the vehicle must be aligned before driving.

Note: The upper arm mounting holes on many cars have been redrilled 1" lower. This is done to improve the handling. Our cross shaft has the drop built into it; **make sure to use the factory mounting holes.**



Upper Control Arm & Spindle Installation



11. Install a 1/2" flat washer, 1/2" split lock washer, and 1/2"-13 nut on the threads of the 2 bolts sticking through into the engine compartment. Torque to 75 ftlbs.



12. Install the spindle on the lower ball joint pin. Torque the ball joint castle nut to 65 ftlbs and tighten to align the cotter pin holes. Install the cotter pin in the ball joint pin hole and bend the ends of the cotter pin to hold it in place. Install the grease zerk supplied with the ball joint.



13. **DISCARD THE BALL JOINT NUT THAT IS SUPPLIED IN THE BALL JOINT KIT. A NEW 1/2"-20 CASTLE NUT IS SUPPLIED IN THE HARDWARE KIT.** Install the spindle on the upper ball joint pin. THREAD THE 1/2"-20 CASTLE NUT SUPPLIED IN THE HARDWARE KIT ON THE THREADS OF THE BALL JOINT PIN. Torque the ball joint castle nut to 50 ftlbs and tighten to align the cotter pin holes. Install the cotter pin in the ball joint pin hole and bend the ends of the cotter pin to hold it in place. Install the grease zerk supplied with the ball joint.



Installing Idler Arm - Stock Steering Box



14. Remove the idler arm that is currently installed on the car. Your current idler arm may have 3 mounting holes, but there is a 2 hole bolt pattern under it. The idler arm supplied with the kit will use the 2 mounting holes circled in **Image 14**.

IF YOU HAVE A BORGESON STEERING BOX ON YOUR FALCON, SKIP TO STEP 16!



15. Attach the new idler arm using the OEM hardware. **Skip to Step 19.**

Installing Idler Arm - Borgeson Power Steering Box



CARS WITH BORGESON POWER STEERING BOX ONLY!!

16. If using a Borgeson steering box, the idler arm needs to be lowered to optimize the steering geometry. The kit includes a spacer block to do this. The spacer block has 2 sets of mounting holes, but each set is only threaded on one side. The idler arm needs to bolt to the set of holes closest to the edge of the spacer block. See **Image 16**.



Installing Idler Arm - Borgeson Power Steering Box



17. The idler mount is attached to the spacer block using (2) 3/8" 16 x 1/2" hex bolts, (2) 3/8" split lock washers, and (2) 3/8" SAE flat washers. Install a 3/8" split lock washer followed by a 3/8" SAE flat washer on each bolt. Line up the idler mount with the bolt pattern the will position it closest to the edge of the spacer block. The idler mount needs to be positioned so the offset positions the pivot under the spacer block. See **Image 17**. Line up the mounting holes with the threaded holes of the spacer block and thread in the bolt/washers into each mounting hole. You can torque these after it is installed on the car.



18. The idler/spacer is attached to the car using (2) 3/8"-16 x 3 1/4" hex bolts, (2) 3/8" split lock washers, and (2) 3/8" SAE flat washers. Install a 3/8" split lock washer followed by a 3/8" SAE flat washer on each bolt. Insert the bolt/washers into the mounting holes circled in Step 14. Thread the bolts into the 2 top holes of the spacer block. Torque all the 3/8" bolts to 35 ftlbs.



19. Install the idler arm on the idler mount with the pin pointing up. Position the pin of the idler to the front of the car before torquing the castle nut. Torque the castle nut to 35-47 ftlbs and tighten to align the cotter pin hole. Install the cotter pin and bend the ends.



Installing Pitman Arm & Centerlink



20. The TruTurn kit includes a new pitman arm. A pitman arm puller is necessary to replace the pitman arm. Remove the OEM pitman arm using a pitman arm puller. If you do not have one, they can usually be rented from your local auto parts store. Install the new pitman arm using **Image 20** as a reference. The large diameter of the centerlink pin taper should be down toward the ground. Torque the nut 85-110 ftlbs.-+



21. Attach the new centerlink in the pitman arm. The centerlink only has a tapered pin on one end, it goes into the pitman arm. Torque the nut of the centerlink pin to 35-47 ftlbs and tighten to align the cotter pin hole. Install the cotter pin and bend the ends.



22. The other end of the centerlink will sit down on the stud of the idler arm. Install the end of the centerlink on the stud and torque the castle nut to 25-30 ftlbs. Tighten the nut to align the cotter pin. Install the cotter pin and bend the ends.



Centerlink Adapter Installation



23. The studs with the long hex on them will get installed into the factory centerlink with the taper going into the centerlink, a 7/16" castle nut is used to attach it to the centerlink. The straight shank will point to the front of the car.

Note: It may be necessary to install 7/16" washers under the castle nut to get the cotter pin engaged properly.



24. Torque the nuts to 35 ftlbs and tighten as needed to align cotter pin. Install cotter pin and bend the ends.

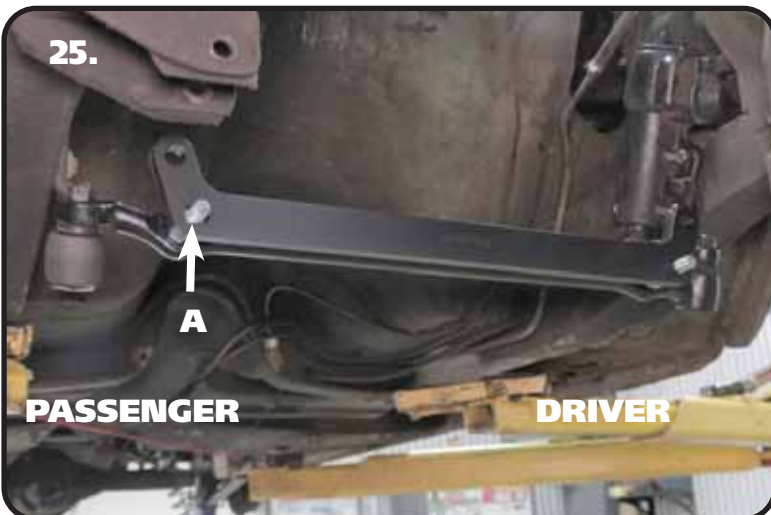

25. The centerlink bracket has one attachment hole [A] that is slotted. This is to accommodate the variations in manufacturing and machining processes, as well as any wear that may have occurred to the original centerlink over time. The slot goes on the passenger side centerlink adapter stud.



Centerlink Adapter Installation

26.



26. Install the 1/2"-20 mechanical locking nuts and torque to 50 ftlbs.

27.



27. The studs with the short hex get installed into the centerlink adapter. The short side goes into the adapter attached with the 5/8"-18 thin top lock nut, with the long side of the stud pointing forward.

28.



28. Install the 5/8"-18 **THIN** mechanical locking nut on the threads of the stud sticking through the centerlink adapter and torque to 45 ftlbs.



Steering Arm & Stop Installation

29a.

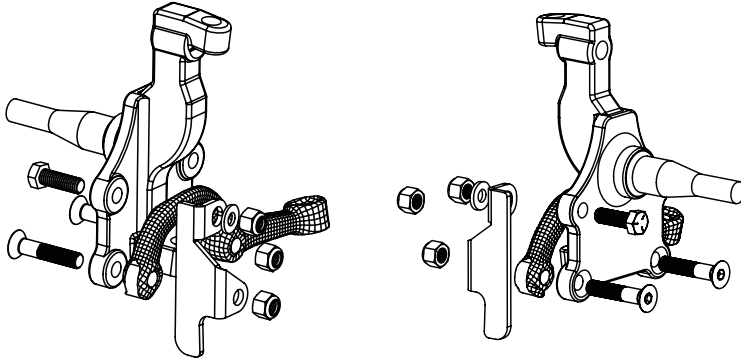

PASSENGER

DRIVER

29a. Install the steering arms and steering stops onto the spindle using **Images 29a & 29b** as a reference. The steering arms angle toward the centerlink, and the tie rod mounting holes are to the rear of the car. The steering stops are marked D and P.

The steering arm is attached to the spindle using 1/2"-20 x 2 1/2" flat socket cap bolts and nylok nuts. Torque to 100 ftlbs.

The upper tab of the steering stop is attached to the spindle using 1/2"-13 x 1 1/2" hex head bolt, 1/2" SAE flat washer, and Nylok. Torque to 75 ftlbs.

29b.

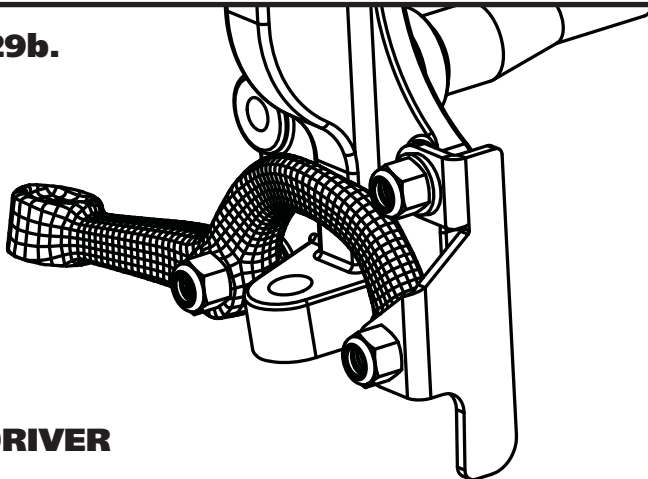

DRIVER

29b. You will notice in **Image 29b**, the bottom hole of the steering stop is mounted on top of the front steering arm mounting hole. The top mounting tab of the steering stop is on the engine side of the spindle.

30.



30. Install the stud with the round flange into the steering arm with the taper going into the steering arm. Torque the nuts to 35 ftlbs and tighten as needed to align cotter pin hole and install cotter pin.



Tie Rod Assembly & Installation

31.

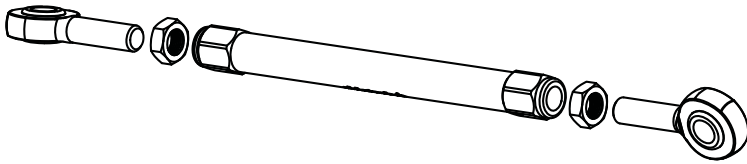

31. The tie rod adjuster has 2 threads in it; 5/8"-18 RH & 5/8"-18 LH. The 5/8"-18 LH thread is marked with a groove on the outside of the adjuster. The tie rod can now be assembled to a center to center length of xx xx" to start with, having equal amount of threads on both ends. These aluminum adjusters have a left hand thread on one end and a right hand thread on the other. You should use anti seize when threading the heim ends into the adjuster. **FOR YOUR SAFETY, THE TIE ROD & HEIM NEED A MINIMUM OF 15/16" OF THREAD ENGAGEMENT INTO THE TIE ROD ADJUSTER.**

32.



32. Install one end of the tie rod onto the stud of the centerlink adapter. Install a 5/8"-18 mechanical locking nut on the threads of the stud and torque to 45 ftlbs.

IF YOU HAVE A BORGESON STEERING BOX ON YOUR FALCON, SKIP TO STEP 34!

33.



33. **STOCK STEERING BOX ONLY!** Install the outer end of the tie rod on the steering arm stud. Skip to Step 35.



Tie Rod Installation



CARS WITH BORGESON POWER STEERING BOX ONLY!!

34. Install a 5/8" ID x 3/8" spacer on the steering arm stud, followed by the outer end of the tie rod.



35. Install the 5/8" ID x .125" spacer on the stud followed by a 5/8" 18 mechanical locking nut. Torque to 45 ftlbs.

36. Double check that you have tightened all hardware to the proper torque. If you are going to install the Ridetech MuscleBar, now is a good time to do it.

Suggested Alignment Specs:

Camber: Street: -.5 degrees
Caster: Street: +3.0 to + 5.0 degrees
Toe: Street: 1/16" to 1/8" toe in



Part # 12283510 - 61-65 Ford Falcon Front HQ CoilOver for StrongArms

Recommended Tools

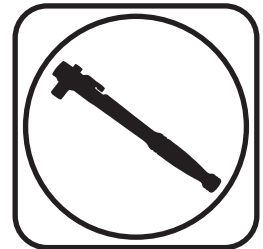
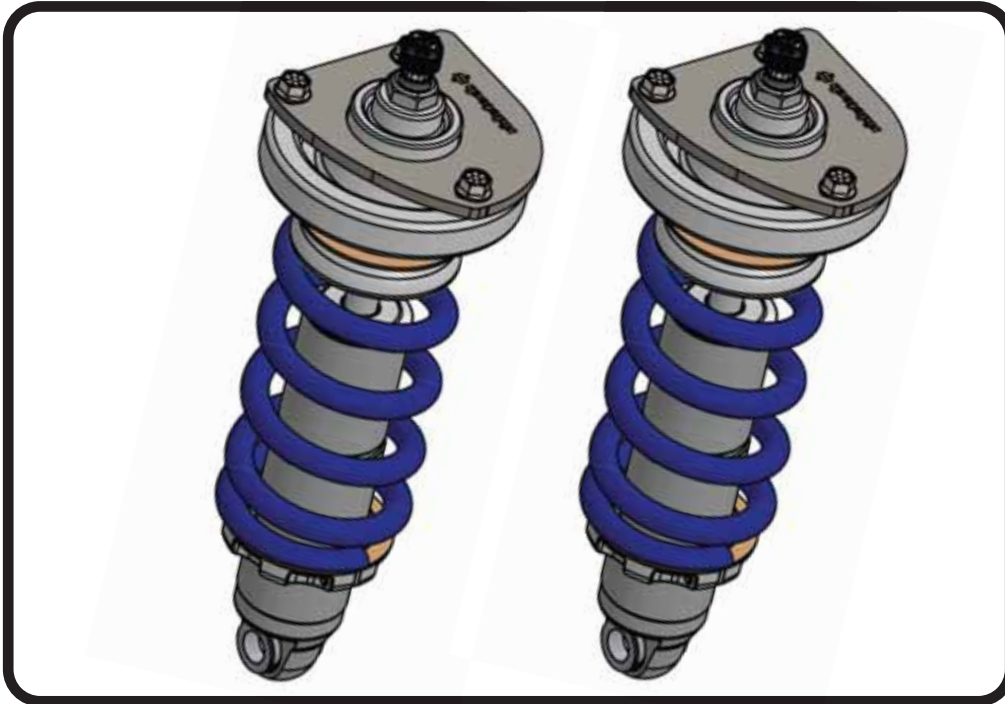

1961-1965 Ford Falcon HQ Series Front CoilOvers

Installation Instructions

THESE COILOVERS ARE DESIGNED TO BE USED WITH RIDETECH STRONGARMS

Table of contents

- Page 21..... Included Components
- Page 22..... Getting Started & Disassembly
- Page 23..... CoilOver Assembly
- Page 24-25..... CoilOver Installation
- Page 26..... CoilSpring Adjusting

CoilOver Dimensions:

- Center of bearing to Stud Mounting Surface:
- Compressed: 9.73"
- Ride Height: 11.50"
- Extended: 13.33"

www.ridetech.com





Major ComponentsIn the box

Item #	Part #	Description	QTY
1	59080475	Coilspring 8" 475lb	2
2	982-10-803	3.6" Stroke HQ Series Shock	2
3a	803-00-199(kit)	Lower Spring Adjuster Nut	2
3b	803-00-199(kit)	Adjuster Nut Locking Screw	2
3c	803-00-199(kit)	CoilSpring Plate Retaining Ring	2
4	90002070	Dropped Upper CoilSpring Retainer	2
5	70010828	Delrin Spring Washer	4
6	90009988(kit)	2.00" Stud Adjuster Assembly	2
7	70012160	2.00" Metering Rod	2
8	90002312	2.00" Stud Top Base	2
9	90001903	Delrin Ball Lower Half	2
10	90001904	Delrin Ball Top Half	2
11	90001902	Delrin Ball Upper Cap	2
12	210-35-120-0	Shock Adjuster Knob	2
13	90009969	Adjuster Knob Retaining Screw	2
14	90001994	5/8" ID Bearing	2
15	90001995	Bearing Snap Ring	4
16	90003201	Upper Shock Mount	2
17	90003202	Upper Shock Mount Top Plate	2
18	99311012	5/16"-18 x 1" Flange Bolt	6
19	99562003	9/16-18" Nylok Nut	2

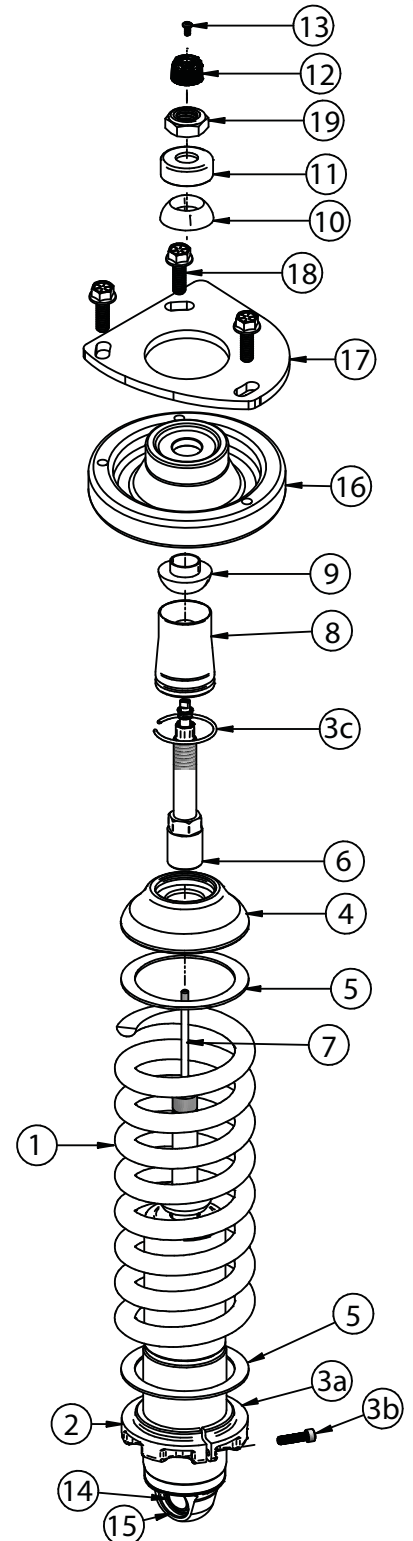



Getting Started.....

THESE COILOVERS ARE DESIGNED TO BE USED WITH RIDETECH STRONGARMS!

The front OEM Shock and Spring assemblies will need to be removed from the front of the car.

1. Raise the vehicle and support it by the frame, allowing the suspension to hang freely. Remove the wheels.
2. If you haven't installed the front StrongArms, do so before installing the CoilOvers. Refer to the StrongArms instructions.

Disassembly



3. The OEM upper shock mount will need to be removed from the car. Remove the upper shock nut and unbolt the mount.



4. If you haven't done so already, remove the shock spring assembly out of the car.



CoilOver Assembly

5.

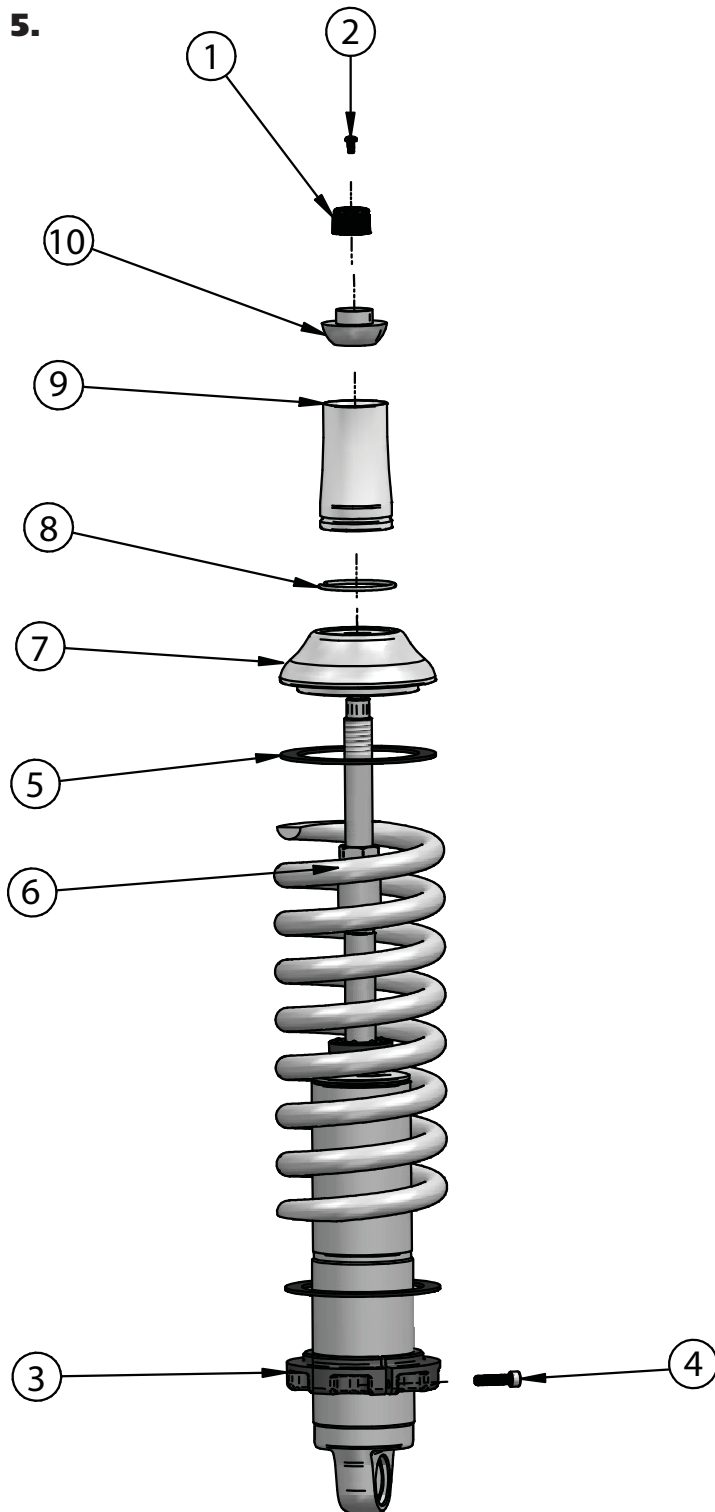

5. To Assemble the CoilOver you need to:
 - a. Remove Screw (2) from center of Adjustment Knob (1) and remove Adjustment Knob.
 - b. Remove Nylok Nut, Delrin Upper Cap, Delrin Upper and Lower Balls, along with the base from the CoilOver stud.
 - c. Thread Adjuster Nut (3) onto the CoilOver body. Once it is threaded on the shock body, lightly thread in the locking screw (4) into the Adjuster Nut.
 - d. Install a Delrin Spring Washer (5) onto the Adjuster Nut.
 - e. Slide the CoilSpring (6) onto the CoilOver.
 - f. Install another Delrin Spring Washer (5) on top of the CoilSpring.
 - g. Install the Dropped Upper CoilSpring Plate (7) onto the CoilSpring.
 - h. Install the CoilSpring Retaining Ring (8) onto the Stud Top Base (9). It fits into the groove in the base.
 - i. Slide the Stud Top Base onto the shock until it bottoms out on the stud. It may be necessary to thread the Adjuster Nut down the shock body (to lower the spring) if the base will not slide all the way down onto the stud.
 - j. Slide the Lower Delrin Ball (10) (it has the collar sticking up around the center hole) on to the Stud Top.

Repeat on second CoilOver.



CoilOver Installation



6. Insert the aluminum shock mount up into the OEM shock tower from the bottom side. The RAISED center of the shock mount will point up.



7. Hold the aluminum upper mount against the bottom of the shock tower, lining up the threaded holes with the factory slots in the shock tower.



8. Lay the upper plate on Top of the shock tower with the shock mount protruding through the large center hole. Line up the holes in the upper plate with the slots in the shock tower and the holes in the shock mount. Install a 5/16" x 1" Flange Bolt in each hole and tighten.



CoilOver Installation

9.

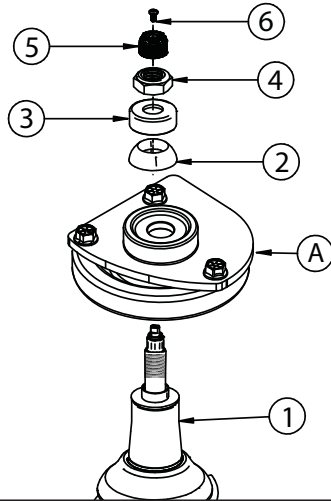

9. Place the CoilOver into the coil spring pocket with the stud sticking through the Aluminum upper mount (A). See assembly **Diagram 9**.

- 1. CoilOver Assembly
- A. Upper Shock Mount
- 2. Delrin ball upper half
- 3. Aluminum cap
- 4. 9/16" SAE Nylok jam nut
- 5. Rebound adjusting knob
- 6. Screw

TIGHTENING THE TOP 9/16"-18 NUT: SNUG THE NUT DOWN AGAINST THE TOP CAP. YOU NEED TO BE ABLE TO ARTICULATE THE SHOCK BY HAND. WE TORQUE THE NUT TO 80 INLBS USING A 7/8" CROWS FOOT WRENCH ON A TORQUE WRENCH.

10.



10. Install a bearing spacer in each side of the Bearing. The SMALL part of the spacer inserts into the Inside diameter of the shock bearing.

11.



11. Raise the lower arm up to the CoilOver. The coilover/spacers will slip between the 2 shock mounting straps of the control arm. Line up the shock mounting holes with the through holes of shock. Install a 1/2" flat washer on a 1/2" x 3 1/2" hex bolt. Insert the bolt/washer in the aligned holes. Install a 1/2" flat washer and 1/2"-13 nylok nut on the threads of the bolt. Torque to 50 ftlbs.



CoilSpring Adjustment

12. Preload the springs of the CoilOver 1" to start. **Steps 12a - 12e** will assist you with preloading the coil spring. You may need to adjust the amount of preload in the spring, but this will be determined after the vehicle has been sat on the ground.

12a. Verify the adjuster nut locking screw is installed in the adjuster nut, but not tight.

12b. Thread the spring adjuster nut up the shock body until it is snug against the spring. You should NOT be able to move the spring up and down on the shock (0 preload). Verify the dropped upper coil spring cap is seated correctly on the upper shock stud.

12c. Measure from the bottom of the adjuster nut to the flat of the shock. You may want to write the measurement down.

12d. Using a spanner wrench, thread the adjuster up the shock an additional 1" (from the measurement you took in step 2) to preload the spring.

12e. Lock the adjusting nut in place by tightening the adjuster nut locking screw.

13. Reinstall the front wheels and tires and set the front of the vehicle back on the ground.

14. After entire weight of vehicle is on the wheels, jounce the suspension and roll the car forward and backward to alleviate suspension bind. **THIS IS NECESSARY BEFORE MEASURING RIDE HEIGHT.**

15. If you determine you need to adjust the ride height of the front suspension after getting the vehicle on the ground, **Steps 15a - 15e** will assist you in adjusting the ride height.

15a. Raise the vehicle and support it by the frame, allowing the suspension to hang freely. You do NOT need to remove the front wheels, but you may want to turn the steering wheel to gain better access to the CoilOver.

15b. Loosen the locking screw in the adjuster nut, but do not remove the locking screw.

15c. Measure from the bottom of the adjuster nut to the flat of the shock. You may want to write the measurement down.

15d. Using a spanner wrench, thread the adjuster up or down the shock to obtain the correct ride height. One complete revolution of the adjuster nut is approximately 1/8" at the wheel. Threading the adjuster nut up the shock will raise the ride height, threading it down will lower the ride height.

15e. Lock the adjusting nut in place by tightening the adjuster nut locking screw.

16. Turn the steering wheel until the front wheels are straight and set the front of the vehicle back on the ground.

17. After entire weight of vehicle is on the wheels, jounce the suspension and roll the vehicle forward and backward to alleviate suspension bind. **THIS IS NECESSARY BEFORE MEASURING RIDE HEIGHT.**

18. Recheck your ride height. If you need to readjust, repeat **Steps 15-17**.



Part # 12289100 - 1961-1965 Falcon Front MuscleBar

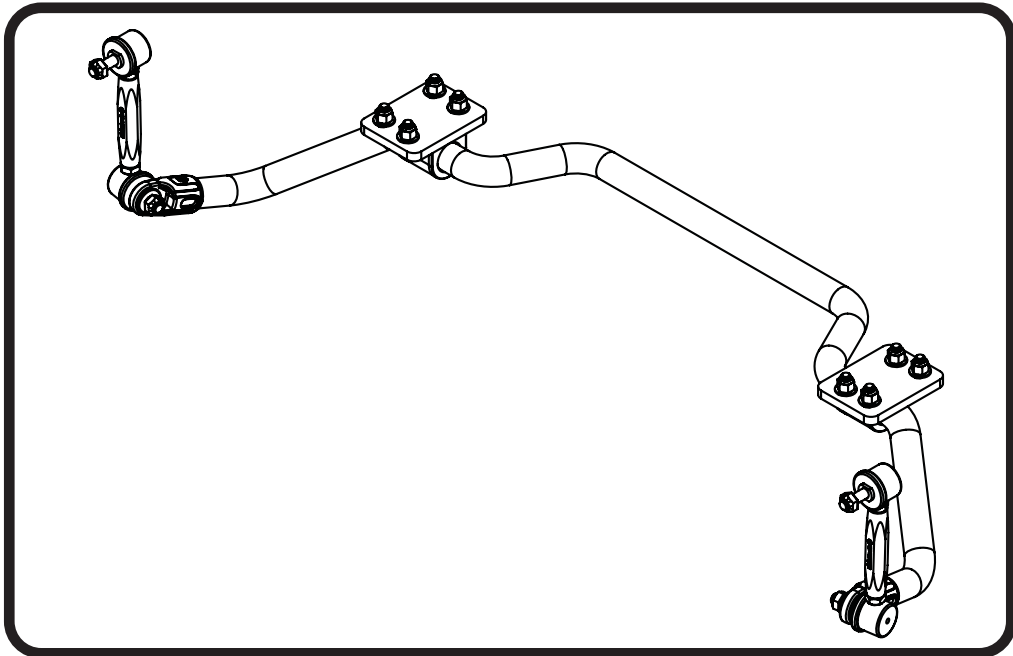

Recommended Tools



1961-1965 Falcon Front MuscleBar Installation Instructions

Table of contents	
Page 28.....	Included Components and Hardware List
Page 29-31.....	Sway Bar Installation

THIS SWAYBAR KIT IS DESIGNED TO BE USED WITH RIDETECH STRONGARMS ONLY. IT WILL NOT FIT THE OEM CONTROL ARMS.



Major ComponentsIn the box

Part #	Description	QTY
90003212	Front Sway Bar	1
90001344	Billet Bushing Strap	2
70015013	Lined Sway Bar Bushing	2
90003213	Offset Mounting Plate	2
90002571	90 Degree End Link	4
90001253	Sway Bar End Link T-Bushing	2
90001258	End Link to Sway Bar Adapter Bushing	4

Hardware ListIn the box (Kit# 99010152)

QTY	Part Number	Description	QTY	Part Number	Description
4	99371005	3/8"-16 x 1 1/4" Hex Bolt	4	99371018	3/8"-16 x 1 1/4" Socket Head Bolt
12	99373002	3/8" SAE Flat Washer	4	99373020	3/8" x 5/8" OD Flat Washer
8	99372001	3/8"-16 Nylok Nut			

Getting Started.....

THIS SWAYBAR KIT IS DESIGNED TO BE USED WITH RIDETECH STRONGARMS ONLY. IT WILL NOT FIT THE OEM CONTROL ARMS.

Install all Front suspension components before installing the MuscleBar.

Remove the OEM sway bar to prepare for the MuscleBar installation.

Note: This sway bar kit utilizes a anti-friction lining in the sway bar bushing. The lining allows the sway bar to move freely and quietly in the bushing. No lubrication is required.



1. Open the sway bar bushing at the split and slip it **OVER** the sway bar. Do this for both bushings.



Sway Bar Installation

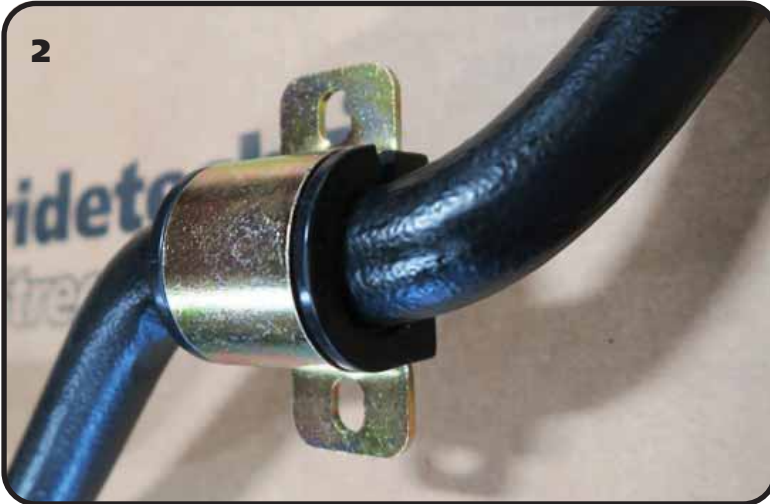

2. Install bushing straps over the poly sway bar bushings.



3. The offset mounting plate will get bolted to the OEM sway bar mount. It is bolted to the OEM holes using the SLOTTED holes in the offset plate with the (2) round holes offset toward the engine. Install a 3/8" flat washer on (2) 3/8"-16 x 1 1/4" hex bolts. A bolt/washer will go in each of the (2) mounting holes. Insert a bolt/washer through each slotted hole and OEM mounting hole. With the bolt/washers installed, install a 3/8" flat washer on the threads followed by a 3/8"-16 nylok nut. Torque the hardware to 30 ftlbs.



4. Slide the sway bar into position on the car. The sway bar arms will be bending upward with the center dropping toward the ground. **Install a 3/8" x 5/8" OD flat washer on (4) 3/8"-16 x 1 1/4" socket head bolts.** A bolt/washer will go in each of the 4 mounting holes. With the bolt/washers installed, install a 3/8" flat washer on the threads followed by a 3/8"-16 nylok nut. Do **NOT** completely tighten the hardware. It will be left partially loose until the end links are installed.



Sway Bar Installation

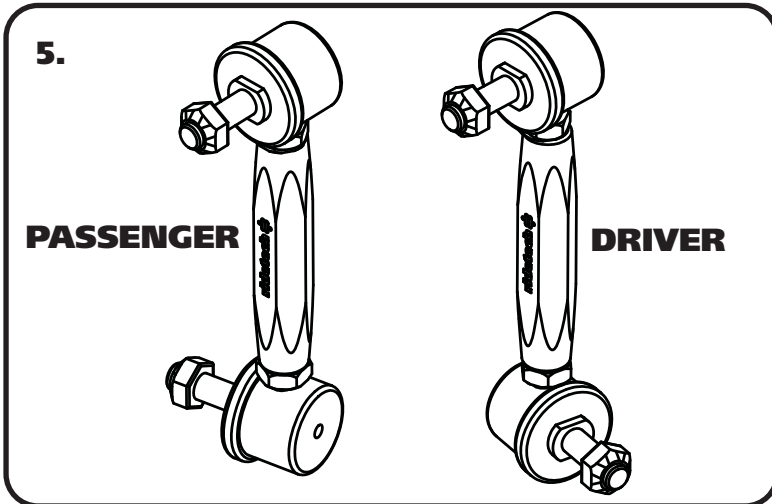

5. The driver and passenger sway bar linkages are clocked opposite of each other. With the top stud pointing toward you, the stud on the lower should be pointing to the right for the driver side, to the left for the passenger side. Using **Diagram 5** as a reference, set the linkage to 6" center to center. Snug the jam nuts against the center adapter.



6. Remove the nut from the top end link. Insert the stud of the end link in the tab of the upper control arm with the stud pointing to the rear of the car. The lower stud should be pointing toward the engine. Install the nut on the stud of the end link and torque to 37 ftlbs. Repeat on the second side.



7. Remove the nut from the bottom end link. Install a t-bushing on the lower 90 degree end link. The t-bushings are installed with the large diameter against the shoulder of the end link.

Drivers side shown in picture.



Sway Bar Installation



8. Insert the 90 degree end link/t-bushing into the swaybar end with the threads pointing toward the engine.



9. Install a 2nd t-bushing with the small diameter into the swaybar. Install the nut and torque to 37 ftlbs. Do this for both sides.



10. Install a 2nd t-bushing with the small diameter into the swaybar. Install the nut and torque to 37 ftlbs. Do this for both sides.

11. The bushing strap hardware can now be tightened. Torque to 30 ftlbs.

12. Check sway bar and end link clearance through full suspension travel.

13. Ensure that the end links do not bind through full suspension travel.



Part # 12287199 -1961-1965 Falcon Rear Bolt-in 4 Link

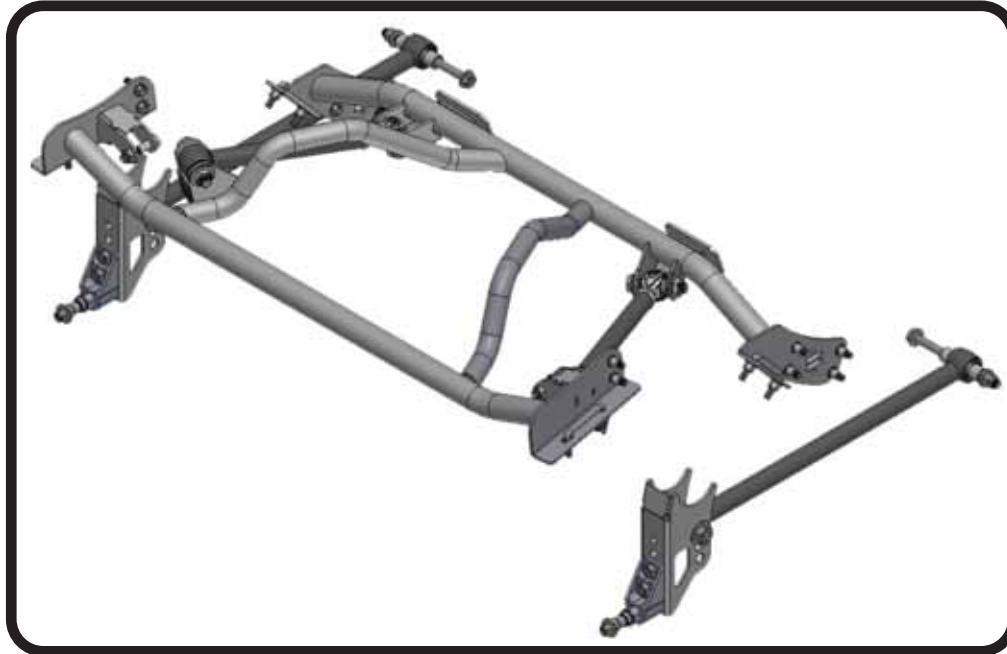

Recommended Tools

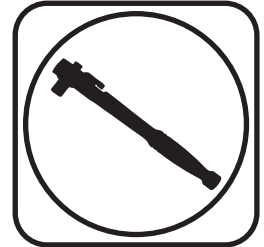

1961-1965 Falcon Rear Bolt-in 4 Link

Installation Instructions

Table of contents

Page 33-35.....	Major Components List, Diagram & Hardware List
Page 36.....	R-Joint Information & Getting Started
Page 37-42.....	Cradle Installation
Page 43.....	Installing Lower Axle Mount
Page 44.....	Lower Shock Mount & Lower Bar Installation
Page 45.....	Lower Bar & Shock Stud Installation
Page 46.....	Shock Stud Installation & Axle Positioning
Page 47.....	Setting Pinion Angle
Page 48.....	Upper Bar Axle Tab Installation
Page 49.....	Installing Axle Tabs & Upper Bars
Page 50.....	Upper Bars & Shock Installation
Page 51.....	Installing ShockWaves/CoilOvers





Major ComponentsIn the box

Item #	Part #	Description	QTY
1	90003214	Upper Cradle	1
2	90002843	Lower Bar Assembly - 21 3/4" center to center	2
3	90002844	Upper Bar - 11 3/4" center to center	2
4	70013767	Front Lower R-Joint Spacer - .500" ID x 1.240" Long (3.00" Wide")	4
5	70013543	Front Lower R-Joint Spacer - .500" ID x 1.00" Long (2.50" Wide")	4
6	90001318	RH R-Joint Threaded Housing End (installed in upper bars)	2
7	99752004	3/4"-16 Jam Nut (installed on upper bar R-Joint)	2
8	70013334	R-Joint Spacers	12
9	90002285	Square U-Bolts	4
10	90003216	Floor Mount Backing Plate	2
11	90002067	Lower Shock Spacers	4
12	90001624	Aluminum Lower Shock Mount	2
13	70002825	Lower Shock Stud	2
14	90002682	Panel Plug - for factory shock holes	2
15	70010694	Bar Tab Setting Jig	2
12287297 - WELD ON BRACKET KIT FOR 3" AXLE TUBES			
16	70014993	Upper Control Arm Outer Axle Tab	2
17	70014994	Upper Control Arm Inner Axle Tab	2
18	70013441	Upper Control Arm Tab Brace	2
19	70014999	Lower Control Arm Axle Mount	2
	99010150	Hardware Kit - List on Page 3	1
R-Joint Components - (Installed in bar ends)			
	70013279	Retaining Ring	8
	70013280	Wavo Wave Spring	8
	70013275	R-Joint Center Ball	8
	70013276	R-Joint Composite Center Ball Cage	8



Part Diagram

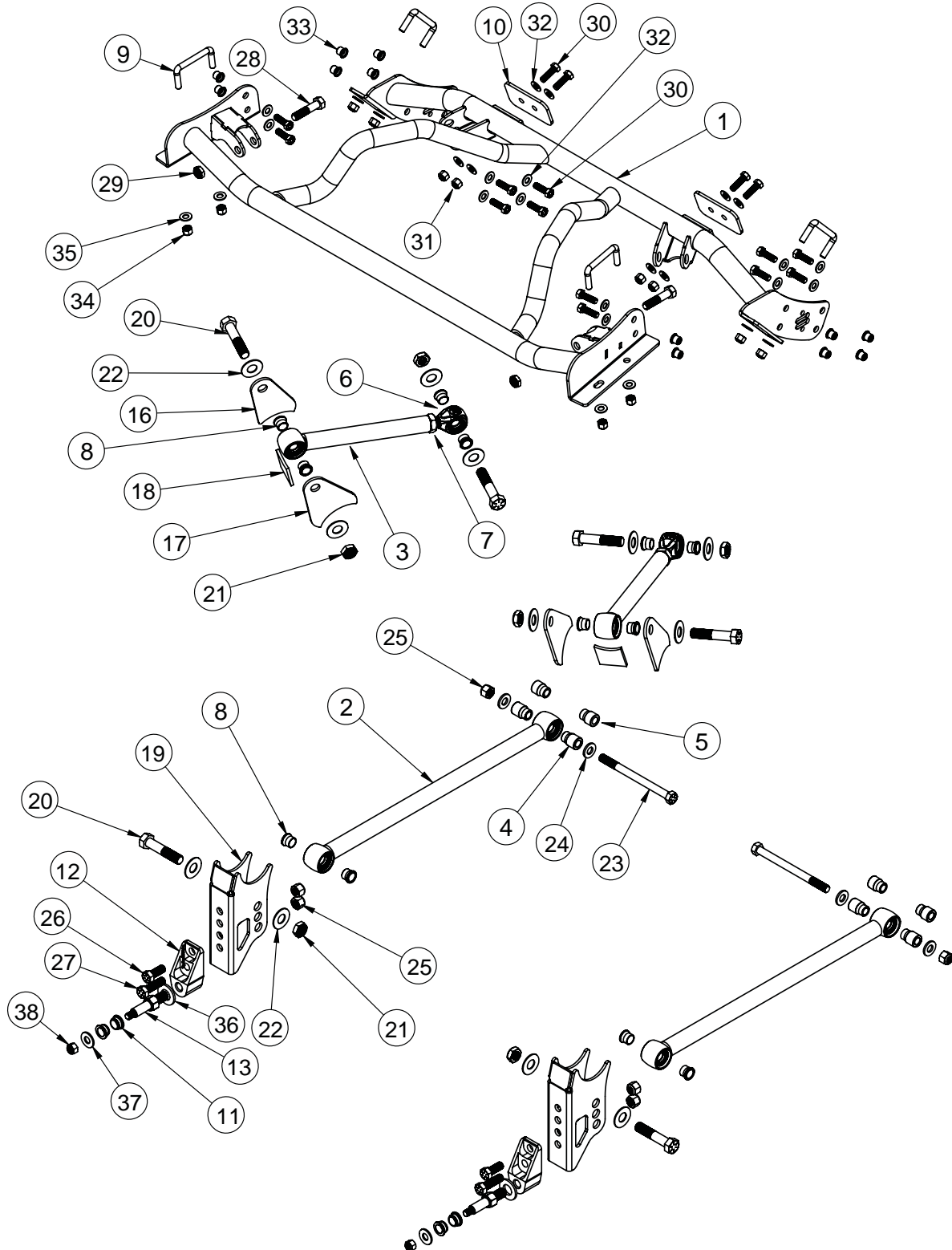



Hardware ListIn the box (Kit# 99010150)

The 4-Link Kit is supplied with a hardware kit. This hardware kit contains individual bags for the different parts of the installation. The bags are labeled to help determine the correct hardware for the installation of the specific parts of the kit. The instructions will aid you in selecting the correct hardware during the installation. The kit includes Rivnuts and installation tool for installation of the rear cradle. Refer to Page 9 for the correct installation procedure of the Rivnuts.

Item #	Upper & Lower Control Arms		QTY
20	99621004	5/8-18 X 3" Hex Bolt Gr8	6
21	99622006	5/8-18 Thin Nylok Jam Nut	6
22	99623001	5/8" SAE Flat Washer Gr8	12
23	99501029	1/2-20 X 6 1/2" Hex Bolt Gr8	2
24	99503014	1/2" SAE Flat Washer Gr8	4
25	99502002	1/2-20 Nylok Nut Gr8	2
Shock Mount To Lower Control Arm Mount			
25	99502002	1/2-20 Nylok Nut Gr8	4
26	99501007	1/2-20 X 1 1/4 Hex Bolt Gr8	2
27	99501009	1/2-20 X 1 3/4 Hex Bolt Gr8	2
Shock To Cradle			
28	99501010	1/2-20 X 2 1/4" Hex Bolt Gr8	2
29	99502003	1/2-20 Thin Nylok Jam Nut	2
Cradle To Floor			
30	99371005	3/8-16 X 1 1/4" Hex Bolt Gr8	4
31	99372001	3/8-16 Nylok Nut Gr8	4
32	99373002	3/8" SAE Flat Washer Gr8	8
Cradle To Frame			
30	99371005	3/8-16 X 1 1/4" Hex Bolt Gr8	12
32	99373002	3/8" SAE Flat Washer Gr8	12
33	99372007	3/8-16 Riv-Nut	12
Not Shown	85000007	17/32" Drill Bit for Riv-Nuts	1
Not Shown	85000008	3/8-16 Riv-Nut Installation Tool	1
Cradle U-Bolts To Frame			
34	99372001	3/8-16 Nylok Nut Gr8	8
35	99373002	3/8" SAE Flat Washer Gr8	8
Shock Stud			
36	99623004	5/8" SAE Flat Washer	2
37	99433002	7/16" SAE Flat Washer	2
38	99432002	7/16"-20 Nylok Nut	2
Bar Setting Jig			
Not Shown	99371001	3/8-16 X 3/4" Hex Bolt Gr5	2
Not Shown	99372004	3/8-16 Hex Nut Gr5	2



R-Joint Information

R-JOINT SPACER INSTALLATION

Install the Spacers by inserting the SMALL side of the SPACER into the Center Pivot Ball. Push them in until they bottom out and stop.

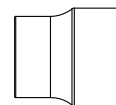
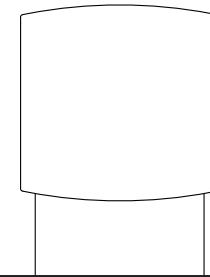
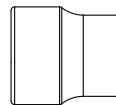

ALL OTHER R-JOINTS

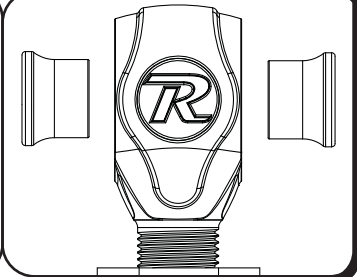

New R-Joints will be quite stiff (75-90 in/lbs breakaway torque) until they “break in” after a few miles of use. After the break in period they will move much more freely. Because the composite bearing race contains self lubricating ingredients, no additional lubrication is needed or desired. Any additional lubrication will only serve to attract more dirt and debris to the R-Joint and actually shorten its life.

Getting Started.....

Congratulations on your purchase of the Ridetech Rear 4-link System. This system has been designed to give your Falcon excellent handling along with a lifetime of enjoyment. This system provides tunability, replaces the leaf springs, and allows the 4-Link to locate the rearend and the CoilOvers/ShockWaves to support the car.

Note: This system is designed for use with the Ridetech Shockwaves or CoilOvers. **The factory shocks and springs will not fit this setup.**

1. Raise the vehicle to a safe and comfortable working height. Use jack stands to support the vehicle with the suspension hanging freely.
2. Support the axle and remove the leaf springs, shocks and tail pipes. Refer to the factory service manual for proper disassembly procedures. The rear seat will also need to be removed.



3. Remove the exhaust hanger reinforcing plate from the passenger side frame rail. This plate is on the inside of the frame rail, between the fuel tank and axle. We removed it by grinding into the spot welds and using a chisel.



Cradle Installation



4. We suggest recruiting an assistant to help install the cradle in the car. The cradle will get positioned in the car with the lower tabs of the side plates against the bottom of the frame rail and the (2) forward tabs against the floor pan.



5. With the cradle held in place, clamp the front frame mounts of the cradle to the frame rails.



6. Use a jack under the rear crossmember of the cradle to help hold it up in place.



Cradle Installation



7. Center punch the holes of the vertical surfaces of the frame mounts. These holes use Rivnuts to bolt the cradle to the frame. The holes need to be centered as much as possible. The front frame mount has (4) holes to center punch. The rear frame plate has (2) holes to center punch. Center punch the driver and passenger side holes. Also center punch the front tabs that are touching the floor pan.



8. Use the frame plates as a template to drill the holes in the bottom of the frame rails. Use a 7/16" drill bit to drill the holes. Drill the slotted hole to the outside of the slot.



9. Remove the cradle to drill the side holes and install the Rivnuts. The holes for the Rivnuts NEED to be drilled with the supplied 17/32" drill bit. We suggest drilling the holes with a smaller drill bit first to make it easier to drill with the 17/32" drill bit. Drill all (12) holes in the sides of the frame rails.



Cradle Installation



10. If you haven't done so already, remove the rear seat. Drill the (4) holes for the floor tabs using a 7/16" drill bit.



11. Install the Rivnuts in the sides of the frame rails. **Refer to the Rivnut installation instructions on PAGE 9 for proper Rivnut installation.** Image 11 illustrates a Rivnut being installed. Install all (12) Rivnuts in the frame rails.



12. Image 12 shows (2) of the Rivnuts installed in the frame rail.



Rivnut® Installation & Specs

1. Drill Hole in Frame using the SUPPLIED DRILL BIT keeping the Drill square with the metal.
2. We recommend installing (2) 3/8" Flat Washers between the bolt head and the lower anvil of the installation tool. Thread a Rivnut® onto the supplied Tool. Thread the Rivnut all the way onto the Tool until it stops.
3. Insert the Tool and Rivnut® into the drilled hole 90° to the Frame Rail.
4. The Tool requires (2) 9/16" Wrenches to use. A Ratchet can be used on the top of the Tool.

KEEP THE TOOL AND RIVNUT 90° TO THE SURFACE WHILE TIGHTENING

5. Put a 9/16" Wrench on the Lower Hex of the tool. Use a Wrench or Ratchet on the Top hex to Tighten.
6. Hold the Wrench in one position and turn the TOP HEX CLOCKWISE to engage the Rivnut®. Keep Turning the TOP WRENCH until you feel a positive stop and you can't turn the TOP WRENCH anymore.
7. Break the Tool loose by turning the TOP HEX counterclockwise and thread the Tool out of the Rivnut®

THE DATA BELOW ILLUSTRATES THE STRENGTH OF THE RIVNUT®

RIVNUT® Fastener Engineering Data

Upset Load (lbs.)		
RIVNUT * Size	Steel	
	Min. Grip	Max. Grip
3/8-16	4965	5325

Fig. 1

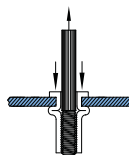

Ultimate thread strength (lbs.)		
RIVNUT * Size	Steel	
	Min. Grip	Max. Grip
3/8-16	11500	10450

Fig.2

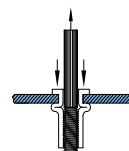

Ultimate tensile strength (lbs.)	
RIVNUT * Size	Steel
3/8-16	3900

Fig. 3

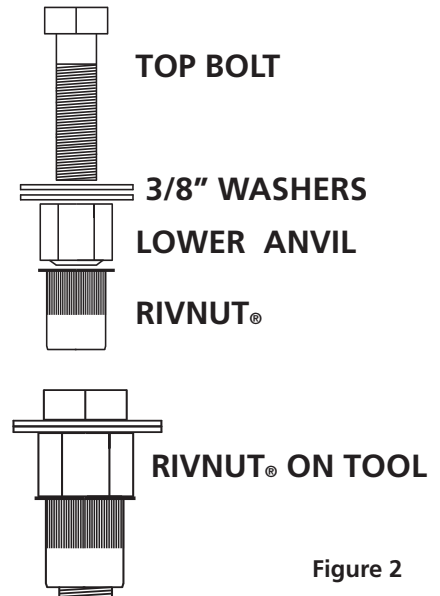
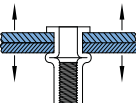

Figure 2

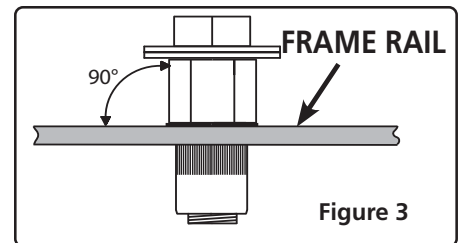

Figure 3

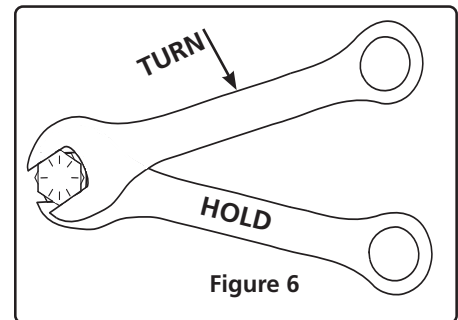

Figure 6

**Single Shear Strength 3/8" Grade 5 Bolt
3,975.8 lbs**



Cradle Installation



13. Reinstall the cradle in the car. Again, clamping it in place is helpful. Install a 3/8" flat washer on each of (12) 3/8"-16 x 1 1/4" hex bolts. Thread a bolt/washer in to each of the Rivnuts installed in the frame rails. Make sure the bottom tabs are against the frame rails before tightening the bolts. Torque the bolts to 23 ftlbs.



14. Install a 3/8" flat washer on each of (4) 3/8"-16 x 1 1/4" hex bolts. Insert the (4) bolt/washers through the floor tabs and floor.



15. Install the backing plates on the bolts sticking through the floor pan. Install a 3/8" flat washer and 3/8"-16 nylok nut on the threads of the bolts sticking through the backing plates. Torque the bolts to 30 ftlbs.



Cradle Installation



16. You will notice that the holes in the bottom of the frame are drilled in pairs. Each pair will receive a Square U-bolt. The U-bolts are installed by inserting one end into one of the drilled holes, using the other end as a handle, and feeding it through the frame until the inserted end will drop down through the remaining hole. Do this for all (4) U-bolts.



17. Feed one end of the u-bolt through the round hole of the pair of holes, using the other end of the u-bolt as a handle. You need to get the end of the u-bolt that you are using as a handle fed in until it is past the 90 degree bend to be able to drop the other end through the drilled hole. If the u-bolt will not line up with the drilled holes, it may be necessary to slot the frame hole in the slotted hole of the frame mount.



18. Install (1) 3/8" Flat washer and (1) 3/8"-16 nylok nut onto each stud sticking through the cradle. Do not tighten them until all Washers and Nuts are installed. Tighten each leg of the u-bolt evenly. Torque to 30 ftlbs. Do this for all (4) u-bolts.



Installing Lower Axle Mounts

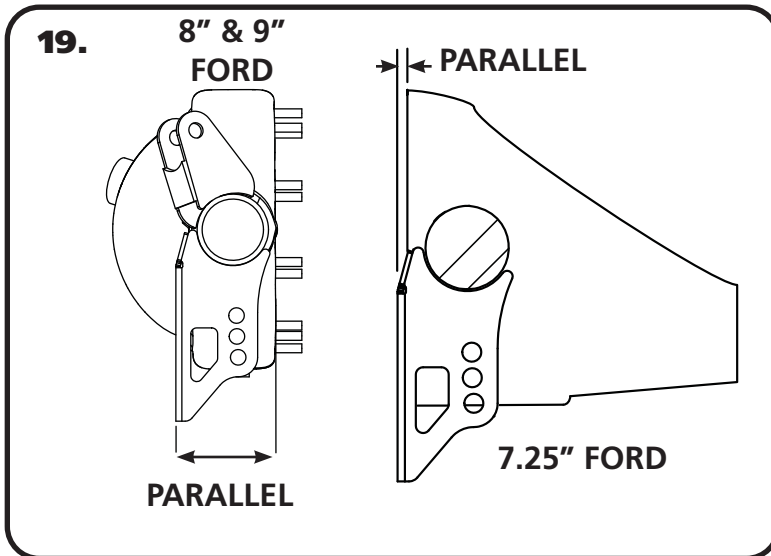

19. The Lower Axle Mounts need to be welded to the rear differential before placing it in the car. The Lower Axle Mounts need to be parallel to the flat surface of the center section. On a 7.25", it is the surface the rear cover bolts to. On 8" & 9", it's the surface the center section bolts to. The axle mounts need to be installed at 45" outside to outside and centered on the differential. **Image 19** shows a side view of a 7.25" and 9" illustrating the surface we used as a reference to place the Lower Mount. It is best done on a flat surface. We start by placing the differential on jack stands. We use a digital angle finder to get the vertical surface, shown in **Image 19**, straight up and down.

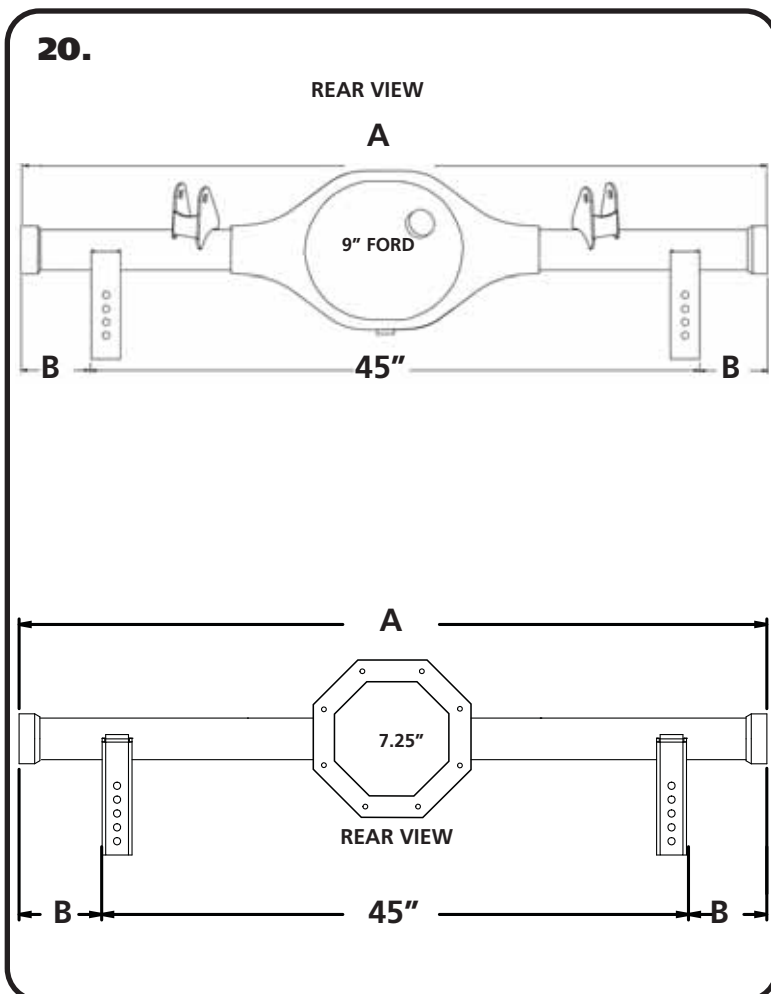

20. The Lower Axle Mounts need to be 45" outside to outside and centered on the differential. Start by establishing a common measurement point on each side of the axle to get a width measurement, Measurement "A". You will need this to get the "B" Measurement to use as a reference when positioning the lower mounts. Once the width measurement "A" is established, subtract 45 from that measurement. Take the remainder of A - 45 and divide by 2. The remainder will be your "B" measurement that will be used on both sides. Using the "B" measurement, measure from the location that was used to establish your width and put a mark on the axle tube. Do this for both sides. To check yourself, measure from mark to mark to verify it is 45". The OUTSIDE EDGE of the lower mounts will be placed at the mark on each side of the differential with the rear surface parallel with vertical surface shown in **Image 19**.

Formula:

$$A - 45 = X$$

$$X/2 = B$$

21. Place the mounts using **Steps 19 & 20**. Tack weld the brackets in place and verify their location. Lay 1" welds on the inside and outside of the lower mounts. Skip around from one side to the other to avoid overheating the tube.



Lower Axle Mount & Lower Bar Installation



22. Attach the lower shock mount to the axle mount using (1) 1/2"-20 x 1 1/4", (1) 1/2"-20 x 1 3/4" hex bolts, and (2) 1/2"-20 Nylok Nuts on each mount. The shock mount is installed in the BOTTOM 2 holes of the axle mount.



23. Depending on the year of your Falcon, the front leaf spring mount may be either 2 1/2" or 3" wide. Measure your car to determine which width of front leaf spring mount you have. This will help determine the width of the R-joint spacers required for your install. The 2 1/2" wide mount will use a 1" wide R-joint spacer in each side of the R-joint. The 3" wide mount will use a 1 1/4" wide R-joint spacer in each side of the R-joint. The lower bars are the longest bars included in the kit. Install the correct R-joint spacers in one end of the lower bars. Slip this end of the lower bar into the front leaf spring mount.



24. The front of the Lower Bar is attached with 1/2"x 6 1/2" Hex Bolt. Install a 1/2" flat washer on the 1/2"-13 x 6 1/2" bolts supplied in the hardware kit. With the R-joint through holes aligned with the OEM leaf spring hole, insert the 1/2" bolt/washer through the aligned mounting holes. Install a 1/2" flat washer and 1/2"-13 nylok nut on the threads of the bolt. Tighten enough to eliminate any gaps in the front mount.



Lower Bar & Shock Stud Installation



25. The Axle end of the bar gets a NARROW(70013334) R-Joint spacer inserted into each side of the R-Joint. Push them in until they stop. Align the R-joint with the **TOP** hole of the axle mount.



26. Install a 5/8" flat washer on a 5/8"-16 x 3" hex bolt. Insert the bolt/washer through the axle mount/bar. Install a 5/8" flat washer and 5/8"-16 thin nylok nut on the threads of the bolt. Do this for both sides. Tighten the bolt/nut enough to eliminate any gaps.



27. Install a 5/8" flat washer onto the 5/8"-18 threads of the shock stud. Apply Red Loctite to the 5/8" threads of the stud.



Shock Stud Installation & Axle Positioning



28. Thread the Shock Stud into the threaded hole of the Lower Mount. Repeat on both sides and torque the Shock Stud to 65-75 ftlbs.



29. One helpful trick to maintain ride height when setting the pinion angle is to put a spacer between the axle and the frame. The spacer should be 4 1/2" tall.



30. Set the pinion angle and axle center. When measuring the axle center you can measure off of the frame rails. We also use a plum bob off the quarter panels to double check the axle center. Refer to **Page 16** on Setting the Pinion Angle.



Setting Pinion Angle

READ PAGES 47 & 48 ON SETTING PINION ANGLES, UPPER BAR TAB JIG INSTALLATION, & SETTING RIDE HEIGHT.

How do you set the pinion angle? On a single-piece shaft you want to set it up where a line drawn through the center of the engine crankshaft or output shaft of the transmission and a line drawn through the center of the pinion are parallel to each other but not the same line.

Your transmission angle should be around 3 degrees down in the rear. If it is more or less than 3 degrees, you might want to consider changing it. Too little angle on the transmission reduces the amount of oil getting to the rear bushing. Too much transmission angle will increase the working angles of the u-joints which will increase the wear. With the transmission at 3 degrees down in the rear, you will want to set the pinion 3 degrees up in the front.

A simple way to do this is to place a digital angle finder or dial level on the front face of the lower engine pulley or harmonic balancer. This will give you a reading that is 90 degrees to the crank or output shaft unless you have real problems with your balancer. At the other end, you can place the same level or angle finder against the front face of the pinion yoke that is also at 90 degrees to the centerline. If you rotate the yoke up or down so both angles match, you have perfect alignment.

Road testing will tell you if you have it right. If you accelerate and you get or increase a vibration, then the pinion yoke is too HIGH. Rotate it downward in small increments of a degree or two until the problem goes away. If you get or increase a vibration when decelerating, then the pinion yoke is too LOW. Rotate it upward to correct it.

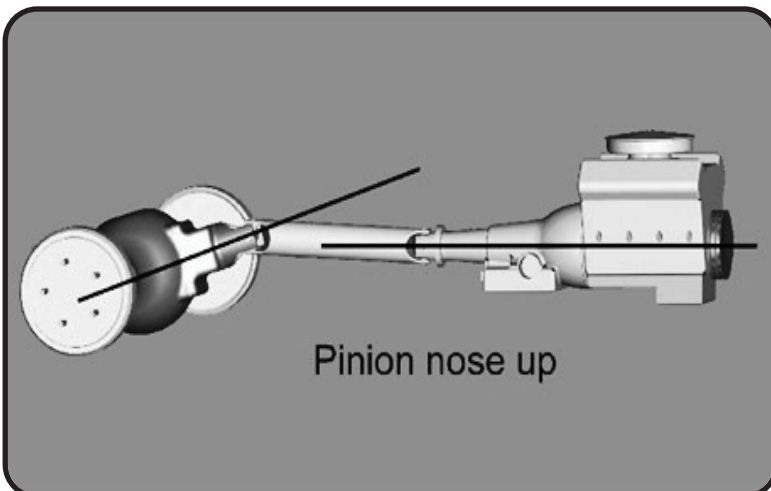
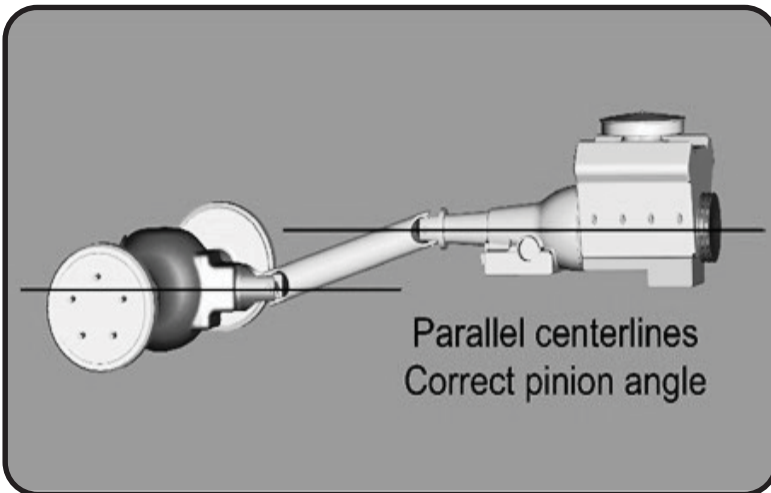
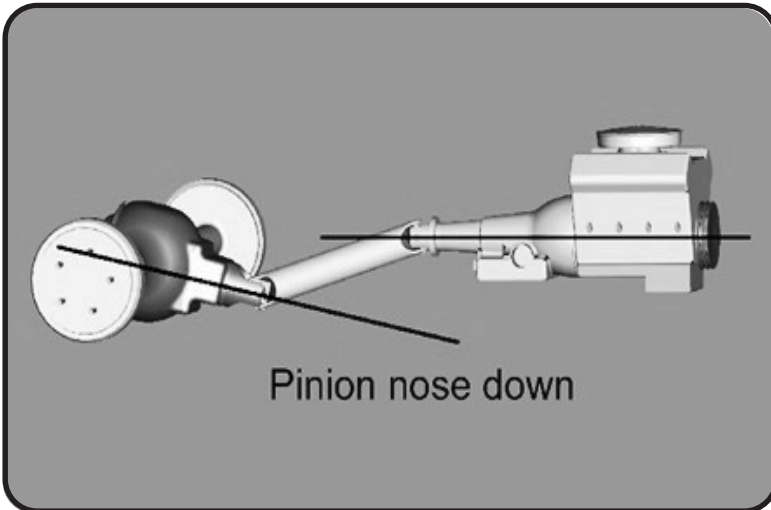



Upper Bar Tab Installation Jig

Upper Bar Installation Jig

- This jig has been supplied to aid in the installation of the upper 4 link bar. It can be temporarily used to properly align, locate and weld the tabs onto the axle. It will also ensure that the mounting bolts are parallel to each other.
- Follow the diagram below to set the jig to the same length as the upper bar, use the 3/8" x 3/4" bolt and nuts to set the length.
- Position the axle at ride height. Center the axle left to right between the quarter panels. Set pinion angle.
- Bolt one end of the jig to the cradle using a 5/8" x 3" bolt.
- Using another 5/8" x 3" bolt, fasten the axle tabs to the other end. Tab 70014993 goes to the outside of the car with the part number to the rear of the car. Tab 70014994 goes to the outside of the car with the part number to the rear of the car. The tabs must be bolted to the outside of the jig.
- Swing the bar down letting the tabs rest onto the axle.
- Check pinion angle, ride height and axle center. Tack-weld the tabs in place.
- Remove jig and install upper bar.
- Repeat this process for the other side.
- Recheck pinion angle, ride height and axle center. (Sound familiar?)
- After the tabs have been tack welded on both sides, remove the upper bars to avoid melting the bushings. Let the axle drop down for better access to the tabs. Lay 1" welds on the inside and outside of the tabs. Skip around from one side to the other to avoid overheating the tube.

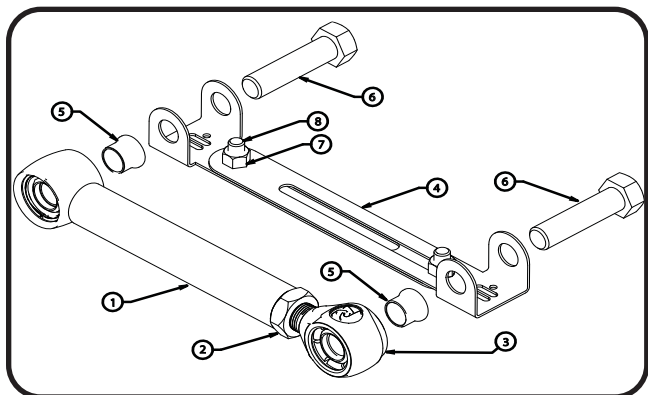

Item#	Description
1	Upper Bar
2	3/4"-16 Jam Nut
3	R-Joint End
4	Alignment Jig
5	Aluminum Spacer
6	5/8" x 3" Bolt
7	3/8"-16 Nut
8	3/8"-16 x 3/4" Bolt



Installing Axle Tabs & Upper Bars



31. Weld the rear brace on each set of axle tabs. The radius needs to be positioned up. Make sure that it isn't welded on the tabs too high, you don't want it to interfere with the R-joint end of the bars.



32. Insert NARROW(70013334) spacers into each side of the R-Joints of the Upper Bar. Align the R-joint with the upper bar mounts in the cradle.



33. Install a 5/8" flat washer on a 5/8"-16 x 3" hex bolt. Insert the bolt/washer through the upper bar mount/bar. Install a 5/8" flat washer and 5/8"-16 thin nylok nut on the threads of the bolt. Do this for both sides. Tighten the bolt/nut enough to eliminate any gaps. Do this for both upper bars.



Upper Bars & Shock Installation



34. When the tabs cool down, insert NARROW(70013334) spacers into each side of the R-Joints of the Upper Bar. Align the R-joint with the upper bar mounts on the axle.



35. Install a 5/8" flat washer on a 5/8"-16 x 3" hex bolt. Insert the bolt/washer through the upper bar mount/bar. Install a 5/8" flat washer and 5/8"-16 thin nylok nut on the threads of the bolt. Do this for both sides. Tighten the bolt/nut enough to eliminate any gaps. Do this for both upper bars.

Note: Steps 36 & 37 cover the CoilOver/ ShockWave installation. CoilOvers can be installed with the shock body up or down. ShockWaves must be installed with the shock body down.



36. Ridetech CoilOvers or ShockWaves require a spacer on each side of the bearing. The upper shock uses a 1/2" ID spacer that is 3/8" long (90002043). The overall width with a spacer on each side will be 1 1/4". **The small side of the spacer goes into the shock bearing.** Insert the Shock with the 1/2" ID Spacers into the shock mount. Line up the holes in the mount with the spacers and shock bearing. Insert a 1/2-20 x 2 1/4" hex bolt into the lined up holes. Install a 1/2"-20 Thin Jam Nylok Nut. Torque to 22 ftlbs



Installing Shockwaves/Coilovers



37. The Shock Stud requires spacers that are .400" long (90002067). Install a 5/8" ID 90002067 spacer (**Small side towards shock body**) onto the lower Shock Stud. Slide the bottom of the Shock onto the Stud. Install a second 5/8" ID 90002067 Spacer onto the Stud (**small side towards shock**). You may need to jack the rearend up to Slide the Shock onto the Stud. Install the 7/16" Flat washer and 7/16" Nylok nut. Tighten the upper and lower shock bolts. Torque the Upper Bolt to 75 ftlbs and the Lower Nut to 40 ftlbs.

NOTE: BEFORE INSTALLING SHOCKWAVES
The correct pinion angle must be set first. Failure to do so could result in damage to the ShockWave by the bag rubbing the Lower Axle Mount.



38. Install the supplied panel plugs in the OEM shock holes.

Note: If installing Shockwaves and you want to locate the air fitting in a different location, the air spring assembly can be rotated on the shock by grabbing the shock and air spring assembly by hand and spinning the shock in the air spring assembly.

The designed ride height of the CoilOver/Shockwave is 14 1/2" center to center.

Double check all the hardware to ensure it is tight.



Part # 12286510

1961-1965 Ford Falcon HQ Rear CoilOvers

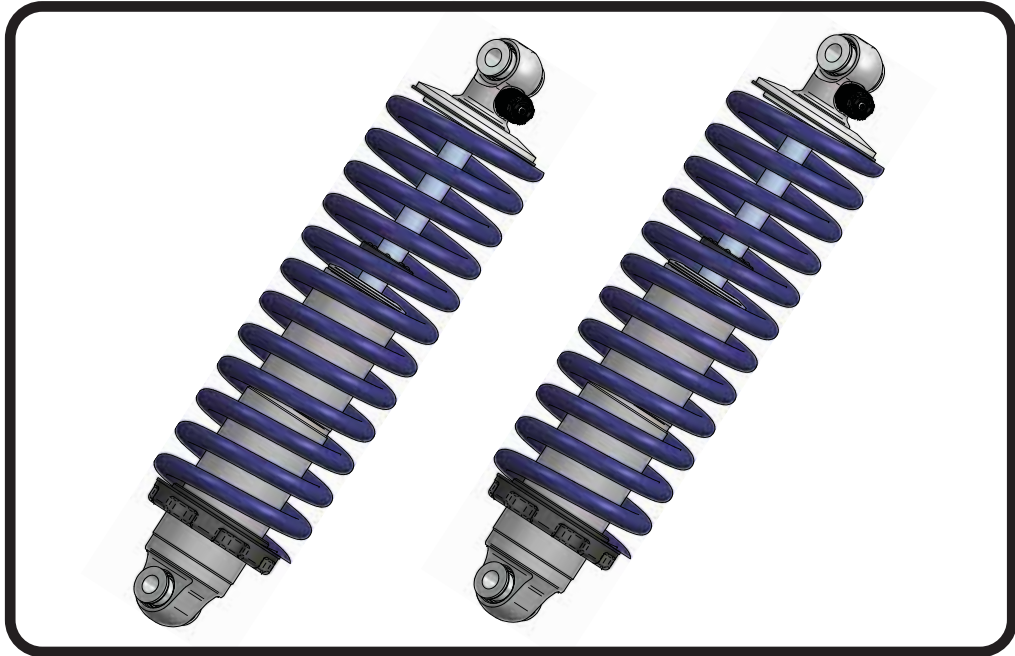

Recommended Tools



1961-1965 Ford Falcon HQ Series Rear CoilOvers

Installation Instructions

Table of contents

Page 53..... Included Components

Page 54..... Assembly and Adjusting

Page 55..... Final Adjustment and Setting Height

CoilOver Dimensions:

Center of bearing to Center of bearing:	
Compressed:	11.23"
Ride Height:	14.50"
Extended:	16.43"



Major ComponentsIn the box

Item #	Part #	Description	QTY
1	982-10-805	5.2" Stroke HQ Series Shock	2
2	815-05-022-KIT	1.7" Shock Eyelet	2
3	803-00-109(kit)	Upper CoilSpring Retaining Plate (803-00-109 kit)	
4	59120150	Coilspring 12" 150lb	2
5	70010828	Delrin Spring Washer	4
6	803-00-109(kit)	Lower Spring Adjuster Nut (803-00-109 kit)	2
7	803-00-109(kit)	Adjuster Nut Locking Screw (803-00-109 kit)	2
8	803-00-109(kit)	Retaining Ring (803-00-109 kit)	2
9	90002043	1/2" ID Upper Shock Bearing Spacer Half	4
	90001994	5/8" ID Bearing (installed in shock and eyelet)	4
	90001995	Bearing Snap Ring (installed in shock and eyelet)	8

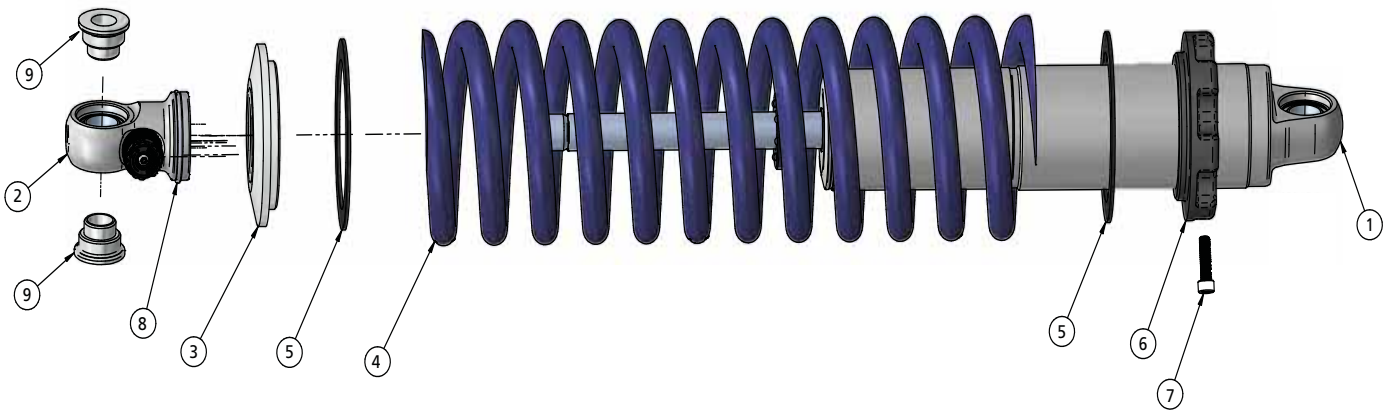



CoilOver Assembly...



1

First, using the supplied lower adjuster nut (803-00-199) thread the nut onto the shock from the bottom side as seen in figure 1. Remove the plastic pellet that is in the split of the adjuster nut.



4

Once the knob is removed slide a Delrin washer over the eyelet. Next, slide the upper spring mount (803-00-199) over eyelet as seen in figure 4.



2

Next, install a delrin washer then coil spring over the top of the shock as seen in figure 2.



5

Install upper spring mount retainer clip (803-00-199) into the groove on the upper eyelet as seen in figure 5. Then, reinstall adjuster to complete assembly.



3

Before the upper spring mount can be installed screw the adjuster knob on the upper eye mount to the firmest setting (clockwise) as seen in figure 3. Then remove the Knob by holding it while removing the center screw.

Install the locking screw in the adjuster nut before setting spring preload, but DO NOT tighten until the spring preload has been set.

NOTE: Remember to adjust the shock valving before driving, the shock is currently set to full stiff.

CoilSpring Adjustment

6. Preload the springs of the CoilOver 1" to start. **Steps 6a - 6e** will assist you with preloading the coil spring. You may need to adjust the amount of preload in the spring, but this will be determined after the vehicle has been sat on the ground.

6a. Verify the adjuster nut locking screw is installed in the adjuster nut, but not tight.

6b. Thread the spring adjuster nut up the shock body until it is snug against the spring. You should NOT be able to move the spring up and down on the shock (0 preload). Verify the upper coil spring cap is seated correctly on the upper shock stud.

6c. Measure from the bottom of the adjuster nut to the flat of the shock. You may want to write the measurement down.

6d. Using a spanner wrench, thread the adjuster up the shock an additional 1" (from the measurement you took in step 2) to preload the spring.

6e. Lock the adjusting nut in place by tightening the adjuster nut locking screw.

7. Reinstall the rear wheels and tires and set the rear of the vehicle back on the ground.

8. After entire weight of vehicle is on the wheels, jounce the suspension and roll the car forward and backward to alleviate suspension bind. **THIS IS NECESSARY BEFORE MEASURING RIDE HEIGHT.**



CoilSpring Adjustment

9. If you determine you need to adjust the ride height of the rear suspension after getting the vehicle on the ground, **Steps 9a - 9e** will assist you in adjusting the ride height.
 - 9a. Raise the vehicle and support it by the frame, allowing the suspension to hang freely. You do NOT need to remove the rear wheels.
 - 9b. Loosen the locking screw in the adjuster nut, but do not remove the locking screw.
 - 9c. Measure from the bottom of the adjuster nut to the flat of the shock. You may want to write the measurement down.
 - 9d. Using a spanner wrench, thread the adjuster up or down the shock to obtain the correct ride height. One complete revolution of the adjuster nut is approximately 1/16" at the wheel. Threading the adjuster nut up the shock will raise the ride height, threading it down will lower the ride height.
 - 9e. Lock the adjusting nut in place by tightening the adjuster nut locking screw.
10. After entire weight of vehicle is on the wheels, jounce the suspension and roll the vehicle forward and backward to alleviate suspension bind. **THIS IS NECESSARY BEFORE MEASURING RIDE HEIGHT.**
11. Recheck your ride height. If you need to readjust, repeat **Steps 9-10.**

Shock Adjustment 101- Single Adjustable

Rebound Adjustment:

How to adjust your new shocks.

The rebound adjustment knob is located on the top of the shock absorber protruding from the eyelet. You must first begin at the ZERO setting, then set the shock to a medium setting of 12.



-Begin with the shocks adjusted to the ZERO rebound position (full stiff). Do this by rotating the rebound adjuster knob clockwise until it stops.

-Now turn the rebound adjuster knob counter clock wise 12 clicks. This sets the shock at 12. (settings 21-24 are typically too soft for street use).

Take the vehicle for a test drive.



-if you are satisfied with the ride quality, do not do anything, you are set!

-if the ride quality is too soft increase the damping effect by rotating the rebound knob clock wise 3 clicks.

Take the vehicle for another test drive.



-if the vehicle is too soft increase the damping effect by rotating the rebound knob clock wise 3 additional clicks.

-If the vehicle is too stiff rotate the rebound adjustment knob counter clock wise 2 clicks and you are set!

Take the vehicle for another test drive and repeat the above steps until the ride quality is satisfactory.

Note: One end of the vehicle will likely reach the desired setting before the other end. If this happens stop adjusting the satisfied end and keep adjusting the unsatisfied end until the overall ride quality is satisfactory.