

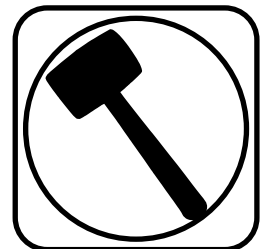

Part # 12287197 -1961-1965 Falcon Rear Bolt-in 4 Link



Recommended Tools



1961-1965 Falcon Rear Bolt-in 4 Link Installation Instructions

Table of contents

Page 2-4.....	Major Components List, Diagram & Hardware List
Page 5.....	R-Joint Assembly
Page 6.....	R-Joint Information & Getting Started
Page 7-12....	Cradle Installation
Page 13.....	Installing Lower Axle Mount
Page 14.....	Lower Shock Mount & Lower Bar Installation
Page 15.....	Lower Bar & Shock Stud Installation
Page 16.....	Shock Stud Installation & Axle Positioning
Page 17.....	Setting Pinion Angle
Page 18.....	Upper Bar Axle Tab Installation
Page 19.....	Installing Axle Tabs & Upper Bars
Page 20.....	Upper Bars & Shock Installation
Page 21.....	Installing ShockWaves/CoilOvers





Major ComponentsIn the box

Item #	Part #	Description	QTY
1	90003214	Upper Cradle	1
2	90003094	Lower Bar Assembly - 21 3/4" center to center	2
3	90003091	Upper Bar - 11 3/4" center to center	2
4	70013767	Front Lower R-Joint Spacer - .500" ID x 1.240" Long (3.00" Wide")	4
5	70013543	Front Lower R-Joint Spacer - .500" ID x 1.00" Long (2.50" Wide")	4
6	90001318	RH R-Joint Threaded Housing End	4
6a	90001319	LH R-Joint Threaded Housing End	4
7	99752004	3/4"-16 Jam Nut	4
7a	99752006	LH 3/4"-16 Jam Nut	4
8	70013334	R-Joint Spacers	12
9	90002285	Square U-Bolts	4
10	90003216	Floor Mount Backing Plate	2
11	90002067	Lower Shock Spacers	4
12	90001624	Aluminum Lower Shock Mount	2
13	70002825	Lower Shock Stud	2
14	90002682	Panel Plug - for factory shock holes	2
15	70010694	Bar Tab Setting Jig	2
12287297 - WELD ON BRACKET KIT FOR 3" AXLE TUBES			
16	70014993	Upper Control Arm Outer Axle Tab	2
17	70014994	Upper Control Arm Inner Axle Tab	2
18	70013441	Upper Control Arm Tab Brace	2
19	70014999	Lower Control Arm Axle Mount	2
	99010150	Hardware Kit - List on Page 3	1



Part Diagram

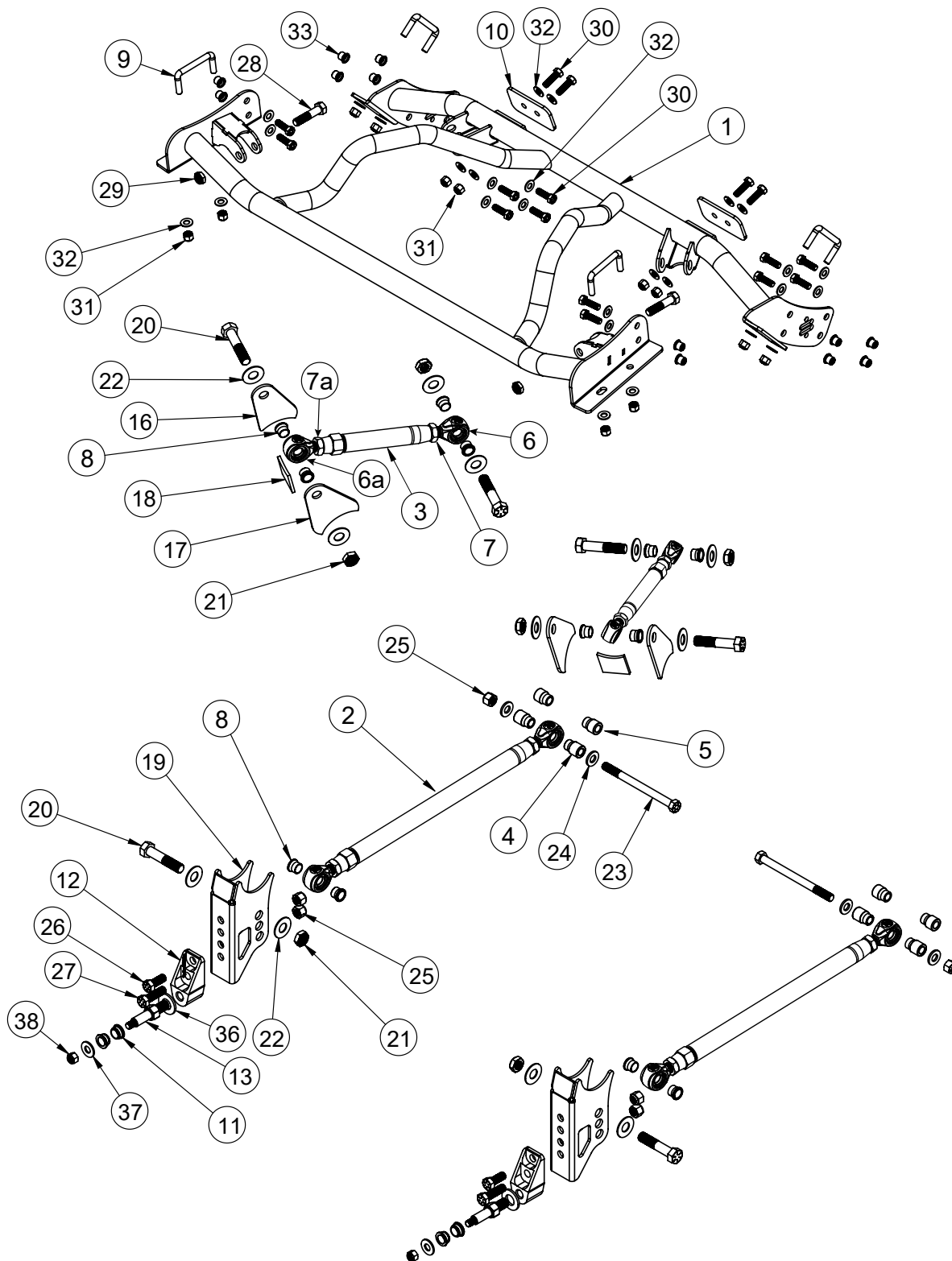



Hardware ListIn the box (Kit# 99010150)

The 4-Link Kit is supplied with a hardware kit. This hardware kit contains individual bags for the different parts of the installation. The bags are labeled to help determine the correct hardware for the installation of the specific parts of the kit. The instructions will aid you in selecting the correct hardware during the installation. The kit includes Rivnuts and installation tool for installation of the rear cradle. Refer to Page 9 for the correct installation procedure of the Rivnuts.

Item #	Upper & Lower Control Arms		QTY
20	99621004	5/8-18 X 3" Hex Bolt Gr8	6
21	99622006	5/8-18 Thin Nylok Jam Nut	6
22	99623001	5/8" SAE Flat Washer Gr8	12
23	99501029	1/2-20 X 6 1/2" Hex Bolt Gr8	2
24	99503014	1/2" SAE Flat Washer Gr8	4
25	99502002	1/2-20 Nylok Nut Gr8	2
Shock Mount To Lower Control Arm Mount			
25	99502002	1/2-20 Nylok Nut Gr8	4
26	99501007	1/2-20 X 1 1/4 Hex Bolt Gr8	2
27	99501009	1/2-20 X 1 3/4 Hex Bolt Gr8	2
Shock To Cradle			
28	99501010	1/2-20 X 2 1/4" Hex Bolt Gr8	2
29	99502003	1/2-20 Thin Nylok Jam Nut	2
Cradle To Floor			
30	99371005	3/8-16 X 1 1/4" Hex Bolt Gr8	4
31	99372001	3/8-16 Nylok Nut Gr8	4
32	99373002	3/8" SAE Flat Washer Gr8	8
Cradle To Frame			
30	99371005	3/8-16 X 1 1/4" Hex Bolt Gr8	12
32	99373002	3/8" SAE Flat Washer Gr8	12
33	99372007	3/8-16 Riv-Nut	12
Not Shown	85000007	17/32" Drill Bit for Riv-Nuts	1
Not Shown	85000008	3/8-16 Riv-Nut Installation Tool	1
Cradle U-Bolts To Frame			
34	99372001	3/8-16 Nylok Nut Gr8	8
35	99373002	3/8" SAE Flat Washer Gr8	8
Shock Stud			
36	99623004	5/8" SAE Flat Washer	2
37	99433002	7/16" SAE Flat Washer	2
38	99432002	7/16"-20 Nylok Nut	2
Bar Setting Jig			
Not Shown	99371001	3/8-16 X 3/4" Hex Bolt Gr5	2
Not Shown	99372004	3/8-16 Hex Nut Gr5	2



R-Joint Bar Assembly

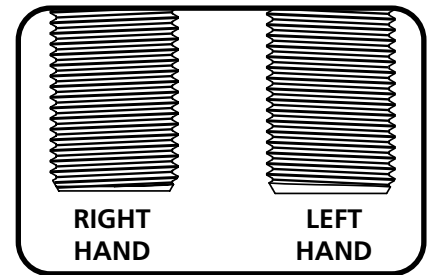
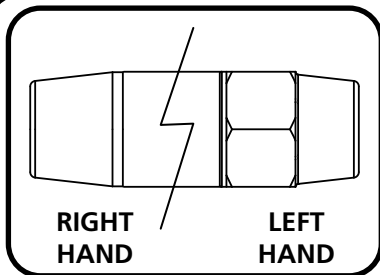

THE 4-LINK BARS, R-JOINTS, AND JAM NUTS HAVE RIGHT HAND AND LEFT HAND THREADS. THIS ALLOWS THE BAR TO BE ADJUSTED WITHOUT REMOVING IT. THE HEX END OF THE BAR IS LEFT HAND THREAD. THE LEFT HAND JAM NUT HAS AN COUNTER-CLOCKWISE ARROW STAMPED INTO IT. IMAGE 3 WILL HELP YOU DETERMINE THE THREADS OF THE R-JOINTS.

14a. Component List:

1. 4-Link Bar
2. Right Hand Thread R-joint
3. Right Hand Thread Jam Nut
4. Left Hand Thread R-Joint
5. Left Hand Thread Jam Nut

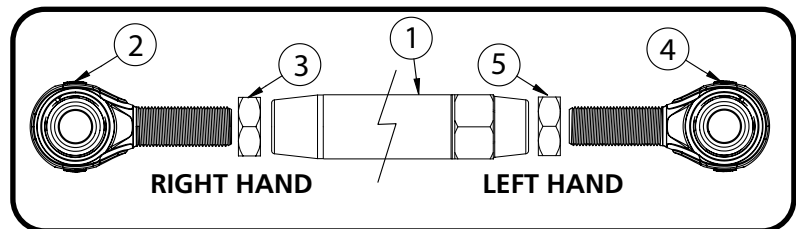

14b. Thread the jam nuts onto the threaded shank of the r-joints. Thread the nuts all the way on to the r-joint.

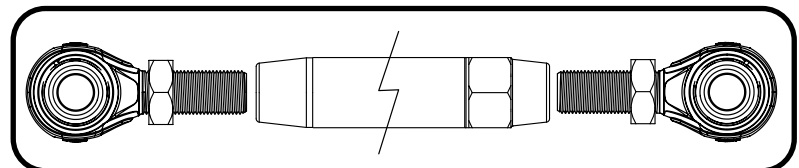

14c. Apply anti-seize to the threads of the r-joint. This will prevent the threads from galling.



14d. Thread the r-joints into the 4-link bar. Thread them in evenly until you achieve the correct center to center length.

Upper Bar Length: 11 3/4"

Lower Bar Length: 21 3/4"

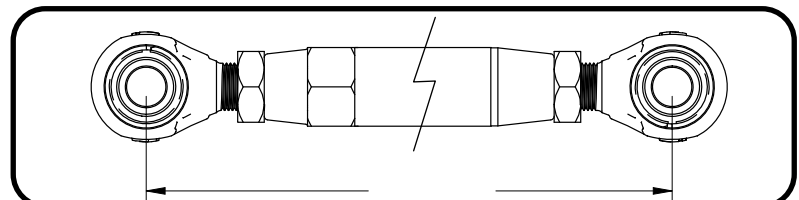

14e. After getting one bar length set, you can put a 5/8" bolt through the r-joints to simplify setting the next bar. Adjust the bar length of the 2nd bar until it will slip on and off the bolts. Torque the jam nuts 65-75 ft-lbs using an 1 1/8" crows foot on a torque wrench.





R-Joint Information

R-JOINT SPACER INSTALLATION

Install the Spacers by inserting the SMALL side of the SPACER into the Center Pivot Ball. Push them in until they bottom out and stop.

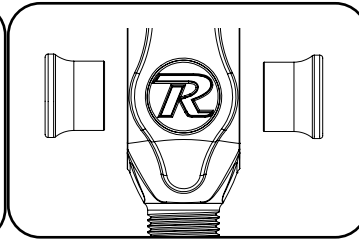

New R-Joints will be quite stiff (75-90 in/lbs breakaway torque) until they "break in" after a few miles of use. After the break in period they will move much more freely. Because the composite bearing race contains self lubricating ingredients, no additional lubrication is needed or desired. Any additional lubrication will only serve to attract more dirt and debris to the R-Joint and actually shorten its life.

Getting Started.....

Congratulations on your purchase of the Ridetech Rear 4-link System. This system has been designed to give your Falcon excellent handling along with a lifetime of enjoyment. This system provides tunability, replaces the leaf springs, and allows the 4-Link to locate the rearend and the CoilOvers/ShockWaves to support the car.

Note: This system is designed for use with the Ridetech Shockwaves or CoilOvers. **The factory shocks and springs will not fit this setup.**

1. Raise the vehicle to a safe and comfortable working height. Use jack stands to support the vehicle with the suspension hanging freely.
2. Support the axle and remove the leaf springs, shocks and tail pipes. Refer to the factory service manual for proper disassembly procedures. The rear seat will also need to be removed.



3. Remove the exhaust hanger reinforcing plate from the passenger side frame rail. This plate is on the inside of the frame rail, between the fuel tank and axle. We removed it by grinding into the spot welds and using a chisel.



Cradle Installation



4. We suggest recruiting an assistant to help install the cradle in the car. The cradle will get positioned in the car with the lower tabs of the side plates against the bottom of the frame rail and the (2) forward tabs against the floor pan.



5. With the cradle held in place, clamp the front frame mounts of the cradle to the frame rails.



6. Use a jack under the rear crossmember of the cradle to help hold it up in place.



Cradle Installation



7. Center punch the holes of the vertical surfaces of the frame mounts. These holes use Rivnuts to bolt the cradle to the frame. The holes need to be centered as much as possible. The front frame mount has (4) holes to center punch. The rear frame plate has (2) holes to center punch. Center punch the driver and passenger side holes. Also center punch the front tabs that are touching the floor pan.



8. Use the frame plates as a template to drill the holes in the bottom of the frame rails. Use a 7/16" drill bit to drill the holes. Drill the slotted hole to the outside of the slot.



9. Remove the cradle to drill the side holes and install the Rivnuts. The holes for the Rivnuts NEED to be drilled with the supplied 17/32" drill bit. We suggest drilling the holes with a smaller drill bit first to make it easier to drill with the 17/32" drill bit. Drill all (12) holes in the sides of the frame rails.



Cradle Installation



10. If you haven't done so already, remove the rear seat. Drill the (4) holes for the floor tabs using a 7/16" drill bit.



11. Install the Rivnuts in the sides of the frame rails. **Refer to the Rivnut installation instructions on PAGE 9 for proper Rivnut installation.** Image 11 illustrates a Rivnut being installed. Install all (12) Rivnuts in the frame rails.



12. Image 12 shows (2) of the Rivnuts installed in the frame rail.



Rivnut® Installation & Specs

1. Drill Hole in Frame using the SUPPLIED DRILL BIT keeping the Drill square with the metal.
2. We recommend installing (2) 3/8" Flat Washers between the bolt head and the lower anvil of the installation tool. Thread a Rivnut® onto the supplied Tool. Thread the Rivnut all the way onto the Tool until it stops.
3. Insert the Tool and Rivnut® into the drilled hole 90° to the Frame Rail.
4. The Tool requires (2) 9/16" Wrenches to use. A Ratchet can be used on the top of the Tool.

KEEP THE TOOL AND RIVNUT 90° TO THE SURFACE WHILE TIGHTENING

5. Put a 9/16" Wrench on the Lower Hex of the tool. Use a Wrench or Ratchet on the Top hex to Tighten.
6. Hold the Wrench in one position and turn the TOP HEX CLOCKWISE to engage the Rivnut®. Keep Turning the TOP WRENCH until you feel a positive stop and you can't turn the TOP WRENCH anymore.
7. Break the Tool loose by turning the TOP HEX counterclockwise and thread the Tool out of the Rivnut®

THE DATA BELOW ILLUSTRATES THE STRENGTH OF THE RIVNUT®

RIVNUT® Fastener Engineering Data

Upset Load (lbs.)		
RIVNUT * Size	Steel	
	Min. Grip	Max. Grip
3/8-16	4965	5325

Fig. 1

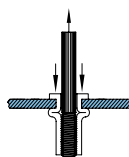

Ultimate thread strength (lbs.)		
RIVNUT * Size	Steel	
	Min. Grip	Max. Grip
3/8-16	11500	10450

Fig.2

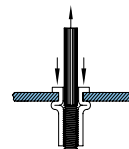

Ultimate tensile strength (lbs.)	
RIVNUT * Size	Steel
3/8-16	3900

Fig. 3

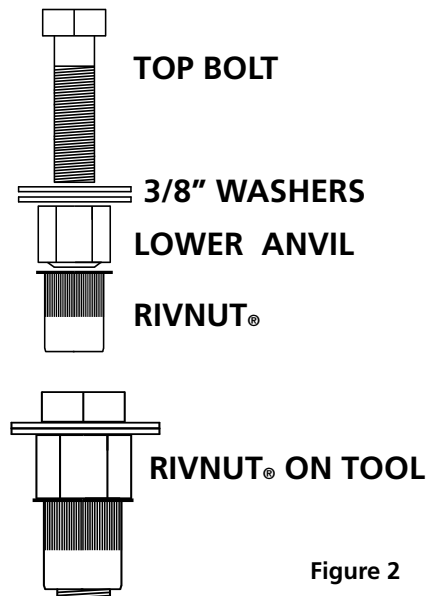
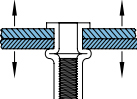

Figure 2

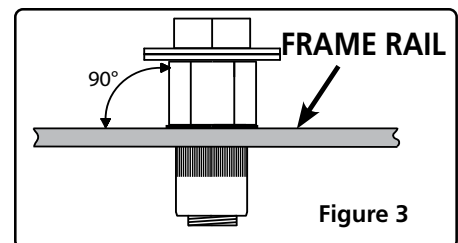

Figure 3

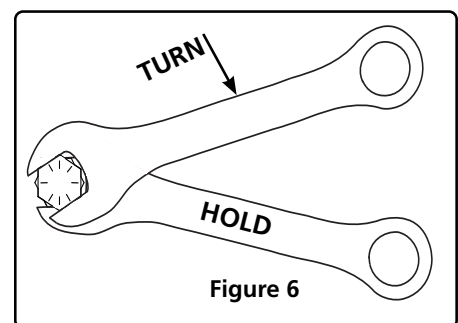

Figure 6

**Single Shear Strength 3/8" Grade 5 Bolt
3,975.8 lbs**



Cradle Installation



13. Reinstall the cradle in the car. Again, clamping it in place is helpful. Install a 3/8" flat washer on each of (12) 3/8"-16 x 1 1/4" hex bolts. Thread a bolt/washer in to each of the Rivnuts installed in the frame rails. Make sure the bottom tabs are against the frame rails before tightening the bolts. Torque the bolts to 23 ftlbs.



14. Install a 3/8" flat washer on each of (4) 3/8"-16 x 1 1/4" hex bolts. Insert the (4) bolt/washers through the floor tabs and floor.



15. Install the backing plates on the bolts sticking through the floor pan. Install a 3/8" flat washer and 3/8"-16 nylok nut on the threads of the bolts sticking through the backing plates. Torque the bolts to 30 ftlbs.



Cradle Installation



16. You will notice that the holes in the bottom of the frame are drilled in pairs. Each pair will receive a Square U-bolt. The U-bolts are installed by inserting one end into one of the drilled holes, using the other end as a handle, and feeding it through the frame until the inserted end will drop down through the remaining hole. Do this for all (4) U-bolts.



17. Feed one end of the u-bolt through the round hole of the pair of holes, using the other end of the u-bolt as a handle. You need to get the end of the u-bolt that you are using as a handle fed in until it is past the 90 degree bend to be able to drop the other end through the drilled hole. If the u-bolt will not line up with the drilled holes, it may be necessary to slot the frame hole in the slotted hole of the frame mount.



18. Install (1) 3/8" Flat washer and (1) 3/8"-16 nylok nut onto each stud sticking through the cradle. Do not tighten them until all Washers and Nuts are installed. Tighten each leg of the u-bolt evenly. Torque to 30 ftlbs. Do this for all (4) u-bolts.



Installing Lower Axle Mounts

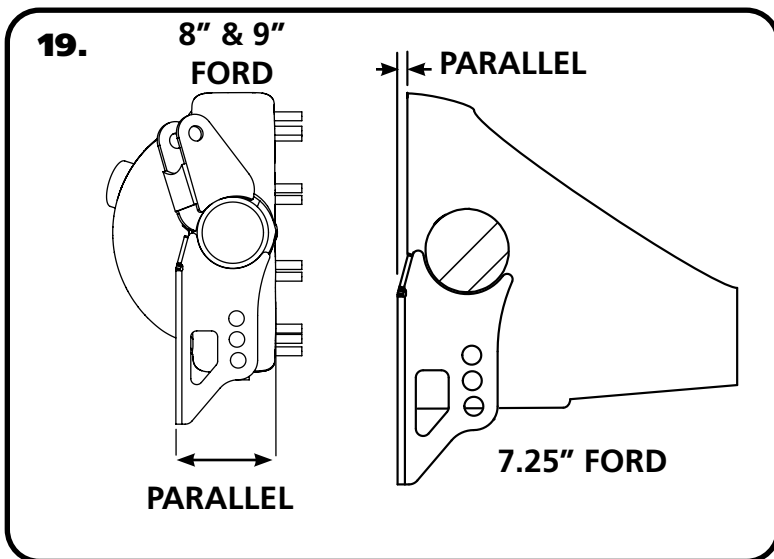

19. The Lower Axle Mounts need to be welded to the rear differential before placing it in the car. The Lower Axle Mounts need to be parallel to the flat surface of the center section. On a 7.25", it is the surface the rear cover bolts to. On 8" & 9", it's the surface the center section bolts to. The axle mounts need to be installed at 45" outside to outside and centered on the differential. **Image 19** shows a side view of a 7.25" and 9" illustrating the surface we used as a reference to place the Lower Mount. It is best done on a flat surface. We start by placing the differential on jack stands. We use a digital angle finder to get the vertical surface, shown in **Image 19**, straight up and down.

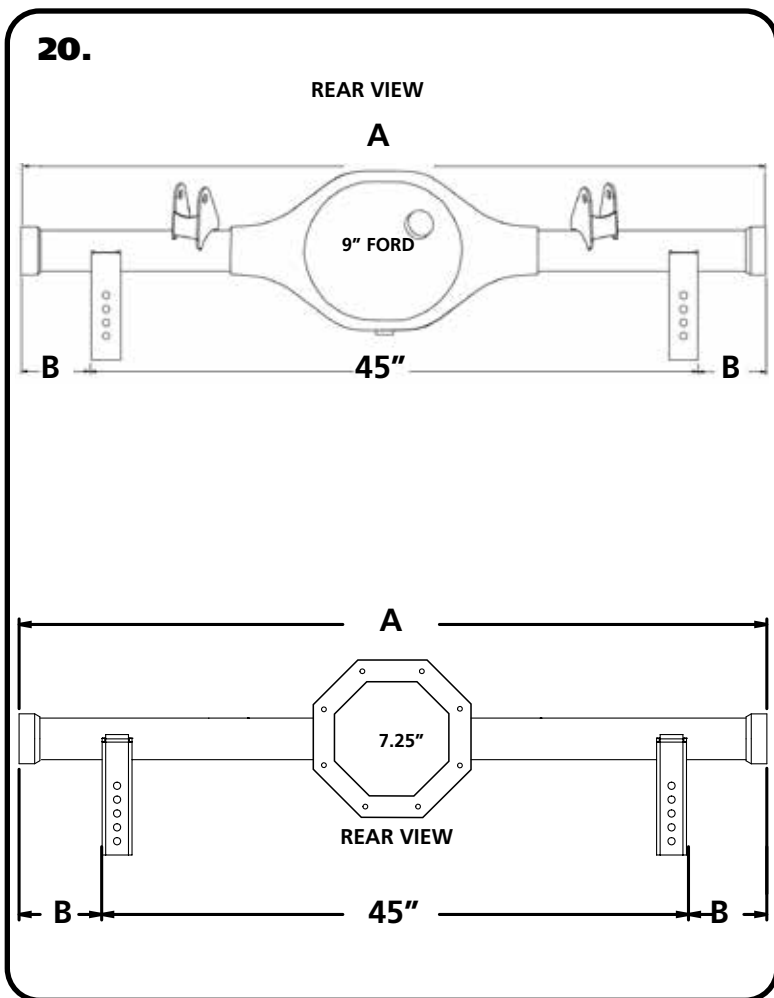

20. The Lower Axle Mounts need to be 45" outside to outside and centered on the differential. Start by establishing a common measurement point on each side of the axle to get a width measurement, Measurement "A". You will need this to get the "B" Measurement to use as a reference when positioning the lower mounts. Once the width measurement "A" is established, subtract 45 from that measurement. Take the remainder of A - 45 and divide by 2. The remainder will be your "B" measurement that will be used on both sides. Using the "B" measurement, measure from the location that was used to establish your width and put a mark on the axle tube. Do this for both sides. To check yourself, measure from mark to mark to verify it is 45". The OUTSIDE EDGE of the lower mounts will be placed at the mark on each side of the differential with the rear surface parallel with vertical surface shown in **Image 19**.

Formula:

$$A - 45 = X$$

$$X/2 = B$$

21. Place the mounts using **Steps 19 & 20**. Tack weld the brackets in place and verify their location. Lay 1" welds on the inside and outside of the lower mounts. Skip around from one side to the other to avoid overheating the tube.



Lower Axle Mount & Lower Bar Installation



22. Attach the lower shock mount to the axle mount using (1) 1/2"-20 x 1 1/4", (1) 1/2"-20 x 1 3/4" hex bolts, and (2) 1/2"-20 Nylok Nuts on each mount. The shock mount is installed in the BOTTOM 2 holes of the axle mount.



23. Depending on the year of your Falcon, the front leaf spring mount may be either 2 1/2" or 3" wide. Measure your car to determine which width of front leaf spring mount you have. This will help determine the width of the R-joint spacers required for your install. The 2 1/2" wide mount will use a 1" wide R-joint spacer in each side of the R-joint. The 3" wide mount will use a 1 1/4" wide R-joint spacer in each side of the R-joint. The lower bars are the longest bars included in the kit. Install the correct R-joint spacers in one end of the lower bars. Slip this end of the lower bar into the front leaf spring mount.



24. The front of the Lower Bar is attached with 1/2"x 6 1/2" Hex Bolt. Install a 1/2" flat washer on the 1/2"-13 x 6 1/2" bolts supplied in the hardware kit. With the R-joint through holes aligned with the OEM leaf spring hole, insert the 1/2" bolt/washer through the aligned mounting holes. Install a 1/2" flat washer and 1/2"-13 nylok nut on the threads of the bolt. Tighten enough to eliminate any gaps in the front mount.



Lower Bar & Shock Stud Installation



25. The Axle end of the bar gets a NARROW(70013334) R-Joint spacer inserted into each side of the R-Joint. Push them in until they stop. Align the R-joint with the **TOP** hole of the axle mount.



26. Install a 5/8" flat washer on a 5/8"-16 x 3" hex bolt. Insert the bolt/washer through the axle mount/bar. Install a 5/8" flat washer and 5/8"-16 thin nylok nut on the threads of the bolt. Do this for both sides. Tighten the bolt/nut enough to eliminate any gaps.



27. Install a 5/8" flat washer onto the 5/8"-18 threads of the shock stud. Apply Red Loctite to the 5/8" threads of the stud.



Shock Stud Installation & Axle Positioning



28. Thread the Shock Stud into the threaded hole of the Lower Mount. Repeat on both sides and torque the Shock Stud to 65-75 ftlbs.



29. One helpful trick to maintain ride height when setting the pinion angle is to put a spacer between the axle and the frame. The spacer should be 4 1/2" tall.



30. Set the pinion angle and axle center. When measuring the axle center you can measure off of the frame rails. We also use a plum bob off the quarter panels to double check the axle center. Refer to **Page 16** on Setting the Pinion Angle.



Setting Pinion Angle

READ PAGES 16 & 17 ON SETTING PINION ANGLES, UPPER BAR TAB JIG INSTALLATION, & SETTING RIDE HEIGHT.

How do you set the pinion angle? On a single-piece shaft you want to set it up where a line drawn through the center of the engine crankshaft or output shaft of the transmission and a line drawn through the center of the pinion are parallel to each other but not the same line.

Your transmission angle should be around 3 degrees down in the rear. If it is more or less than 3 degrees, you might want to consider changing it. Too little angle on the transmission reduces the amount of oil getting to the rear bushing. Too much transmission angle will increase the working angles of the u-joints which will increase the wear. With the transmission at 3 degrees down in the rear, you will want to set the pinion 3 degrees up in the front.

A simple way to do this is to place a digital angle finder or dial level on the front face of the lower engine pulley or harmonic balancer. This will give you a reading that is 90 degrees to the crank or output shaft unless you have real problems with your balancer. At the other end, you can place the same level or angle finder against the front face of the pinion yoke that is also at 90 degrees to the centerline. If you rotate the yoke up or down so both angles match, you have perfect alignment.

Road testing will tell you if you have it right. If you accelerate and you get or increase a vibration, then the pinion yoke is too HIGH. Rotate it downward in small increments of a degree or two until the problem goes away. If you get or increase a vibration when decelerating, then the pinion yoke is too LOW. Rotate it upward to correct it.

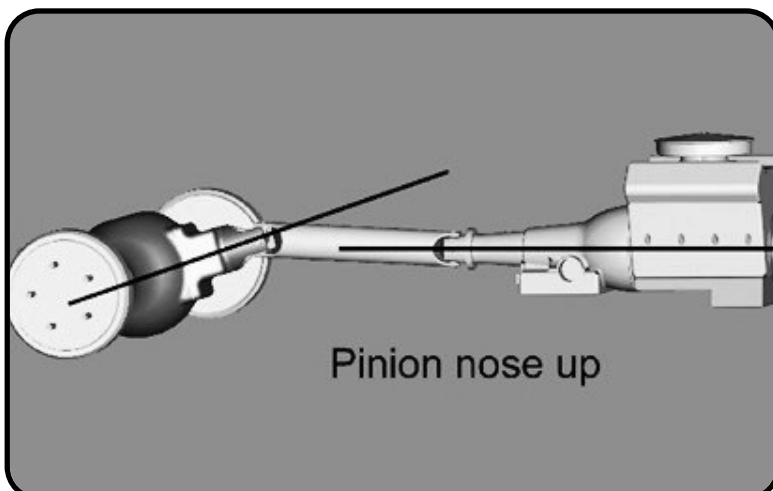
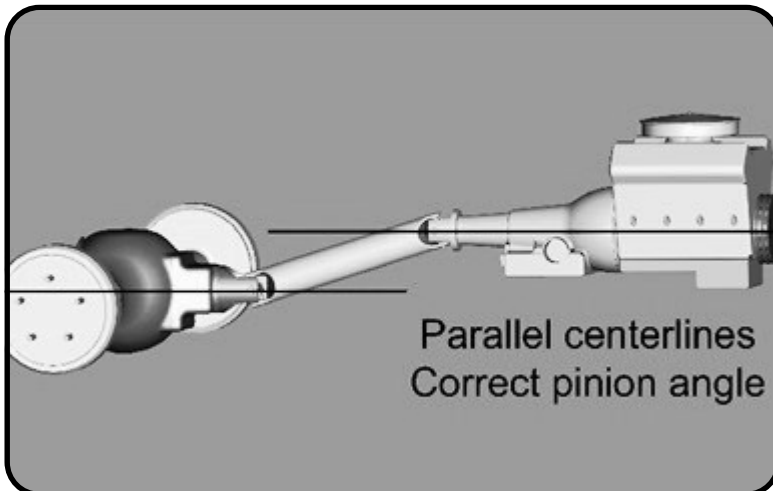
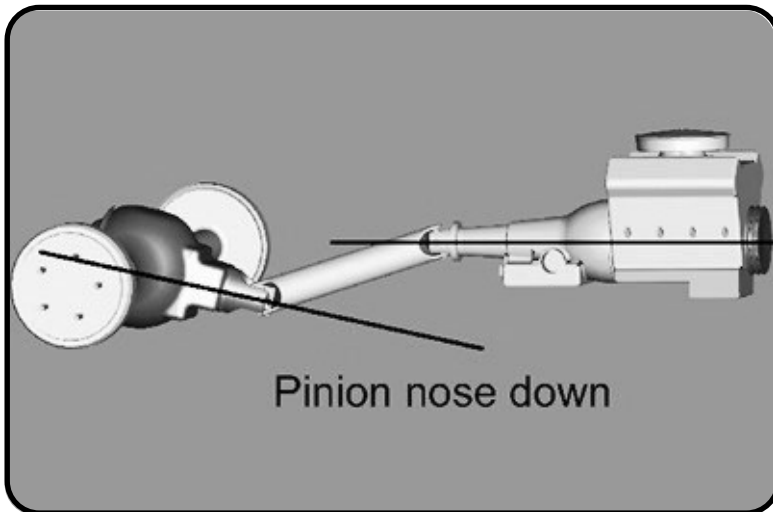



Upper Bar Tab Installation Jig

Upper Bar Installation Jig

- This jig has been supplied to aid in the installation of the upper 4 link bar. It can be temporarily used to properly align, locate and weld the tabs onto the axle. It will also ensure that the mounting bolts are parallel to each other.
- Follow the diagram below to set the jig to the same length as the upper bar, use the 3/8" x 3/4" bolt and nuts to set the length.
- Position the axle at ride height. Center the axle left to right between the quarter panels. Set pinion angle.
- Bolt one end of the jig to the cradle using a 5/8" x 3" bolt.
- Using another 5/8" x 3" bolt, fasten the axle tabs to the other end. Tab 70014993 goes to the outside of the car with the part number to the rear of the car. Tab 70014994 goes to the outside of the car with the part number to the rear of the car. The tabs must be bolted to the outside of the jig.
- Swing the bar down letting the tabs rest onto the axle.
- Check pinion angle, ride height and axle center. Tack-weld the tabs in place.
- Remove jig and install upper bar.
- Repeat this process for the other side.
- Recheck pinion angle, ride height and axle center.
- After the tabs have been tack welded on both sides, remove the upper bars to avoid melting the bushings. Let the axle drop down for better access to the tabs. Lay 1" welds on the inside and outside of the tabs. Skip around from one side to the other to avoid overheating the tube.

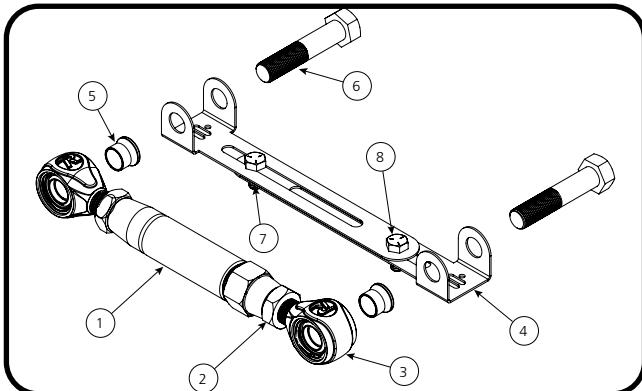

Item#	Description
1	Upper Bar
2	3/4"-16 Jam Nut
3	R-Joint End
4	Alignment Jig
5	Aluminum Spacer
6	5/8" x 3" Bolt
7	3/8"-16 Nut
8	3/8"-16 x 3/4" Bolt



Installing Axle Tabs & Upper Bars



31. Weld the rear brace on each set of axle tabs. The radius needs to be positioned up. Make sure that it isn't welded on the tabs too high, you don't want it to interfere with the R-joint end of the bars.



32. Insert NARROW(70013334) spacers into each side of the R-Joints of the Upper Bar. Align the R-joint with the upper bar mounts in the cradle.



33. Install a 5/8" flat washer on a 5/8"-16 x 3" hex bolt. Insert the bolt/washer through the upper bar mount/bar. Install a 5/8" flat washer and 5/8"-16 thin nylok nut on the threads of the bolt. Do this for both sides. Tighten the bolt/nut enough to eliminate any gaps. Do this for both upper bars.



Upper Bars & Shock Installation



34. When the tabs cool down, insert NARROW(70013334) spacers into each side of the R-Joints of the Upper Bar. Align the R-joint with the upper bar mounts on the axle.



35. Install a 5/8" flat washer on a 5/8"-16 x 3" hex bolt. Insert the bolt/washer through the upper bar mount/bar. Install a 5/8" flat washer and 5/8"-16 thin nylok nut on the threads of the bolt. Do this for both sides. Tighten the bolt/nut enough to eliminate any gaps. Do this for both upper bars.

Note: Steps 36 & 37 cover the CoilOver/ ShockWave installation. CoilOvers can be installed with the shock body up or down. ShockWaves must be installed with the shock body down.



36. Ridetech CoilOvers or ShockWaves require a spacer on each side of the bearing. The upper shock uses a 1/2" ID spacer that is 3/8" long (90002043). The overall width with a spacer on each side will be 1 1/4". **The small side of the spacer goes into the shock bearing.** Insert the Shock with the 1/2" ID Spacers into the shock mount. Line up the holes in the mount with the spacers and shock bearing. Insert a 1/2-20 x 2 1/4" hex bolt into the lined up holes. Install a 1/2"-20 Thin Jam Nylok Nut. Torque to 22 ftlbs



Installing Shockwaves/Coilovers



37. The Shock Stud requires spacers that are .400" long (90002067). Install a 5/8" ID 90002067 spacer (**Small side towards shock body**) onto the lower Shock Stud. Slide the bottom of the Shock onto the Stud. Install a second 5/8" ID 90002067 Spacer onto the Stud (**small side towards shock**). You may need to jack the rearend up to Slide the Shock onto the Stud. Install the 7/16" Flat washer and 7/16" Nylok nut. Tighten the upper and lower shock bolts. Torque the Upper Bolt to 75 ftlbs and the Lower Nut to 40 ftlbs.

NOTE: BEFORE INSTALLING SHOCKWAVES
The correct pinion angle must be set first. Failure to do so could result in damage to the ShockWave by the bag rubbing the Lower Axle Mount.



38. Install the supplied panel plugs in the OEM shock holes.

Note: If installing Shockwaves and you want to locate the air fitting in a different location, the air spring assembly can be rotated on the shock by grabbing the shock and air spring assembly by hand and spinning the shock in the air spring assembly.

The designed ride height of the CoilOver/Shockwave is 14 1/2" center to center.

Double check all the hardware to ensure it is tight.