

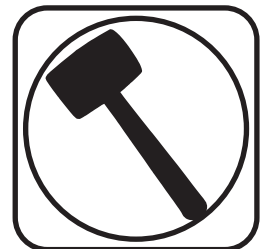

Part # 12289599 - 1961-1965 Ford Falcon Front TruTurn System

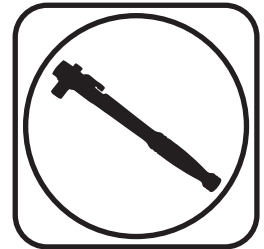

Recommended Tools



1961-1965 Ford Falcon TruTurn System Installation Instructions

Table of contents

Page 2.....	Major Components
Page 3.....	Upper Control Arm Components
Page 4.....	Lower Control Arm Components
Page 5.....	TruTurn Steering Components
Page 6.....	Hardware & Getting Started
Page 7.....	Installing Strut Rod Adapter
Page 8-10.....	Installing Control Arms
Page 10.....	Spindle Installation
Page 11-12.....	Installing Idler Arm
Page 13.....	Installing Pitman Arm & Centerlink
Page 14-15.....	Centerlink Adapter Installation
Page 16.....	Steering Arm & Stop Installation
Page 17-18.....	Tie-Rod Assembly and Installation

Mini-Starter required to clear TruTurn Centerlink Adapter (not Included).

The OEM Front Brakes will not work with this kit. (See Page 6 for details)



Major Components AssembledIn the box

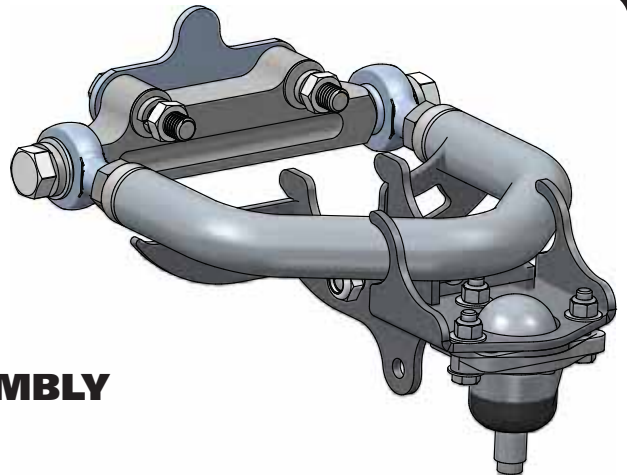

DRIVER UPPER CONTROL ARM ASSEMBLY

Exploded View on Page 3

DRIVER LOWER CONTROL ARM ASSEMBLY

Exploded View on Page 4

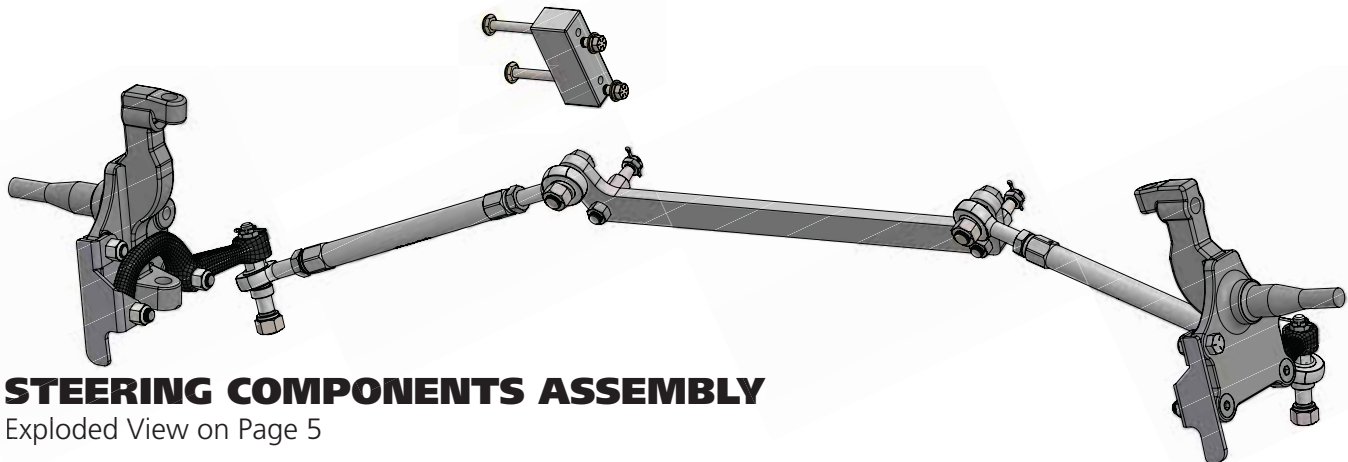
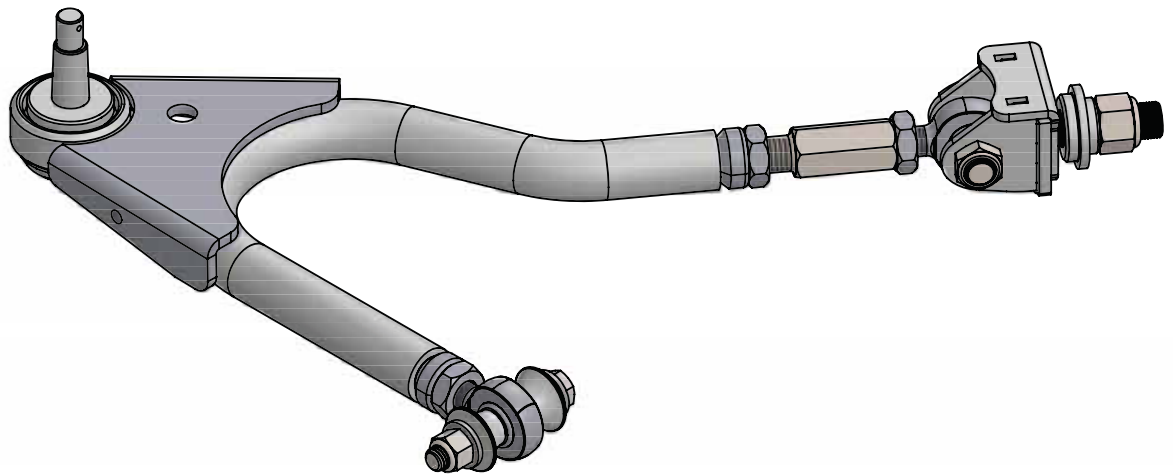

STEERING COMPONENTS ASSEMBLY

Exploded View on Page 5



Upper Control Arm ComponentsIn the box

Item #	Part Number	Description	QTY
1	90002339	Driver Upper Control Arm (Shown)	1
1	90002340	Passenger Upper Control Arm	1
2	90001589	Heim End	4
3	90009967	Upper Cross Shaft	2
4	70010866	Ball joint Assembly - Proforged # 101-10083	2
5	90002633	Ball joint Spacer	2
6	90002341	3/16" Alignment Shim	2
7	99621002	5/18"-18 x 1 3/4" Hex Bolt	4
8	99623001	5/8" SAE Flat Washer	4
9	99623002	5/8" Split Lock Washer	4
10	99311002	5/16"-18 x 1 1/4" Hex Bolt	6
11	99312003	5/16"-18 Nylok Nut	6
12	99313002	5/16" SAE Flat Washer	12
13	90002067	Shock Bearing Spacers	4

Driver Side Shown

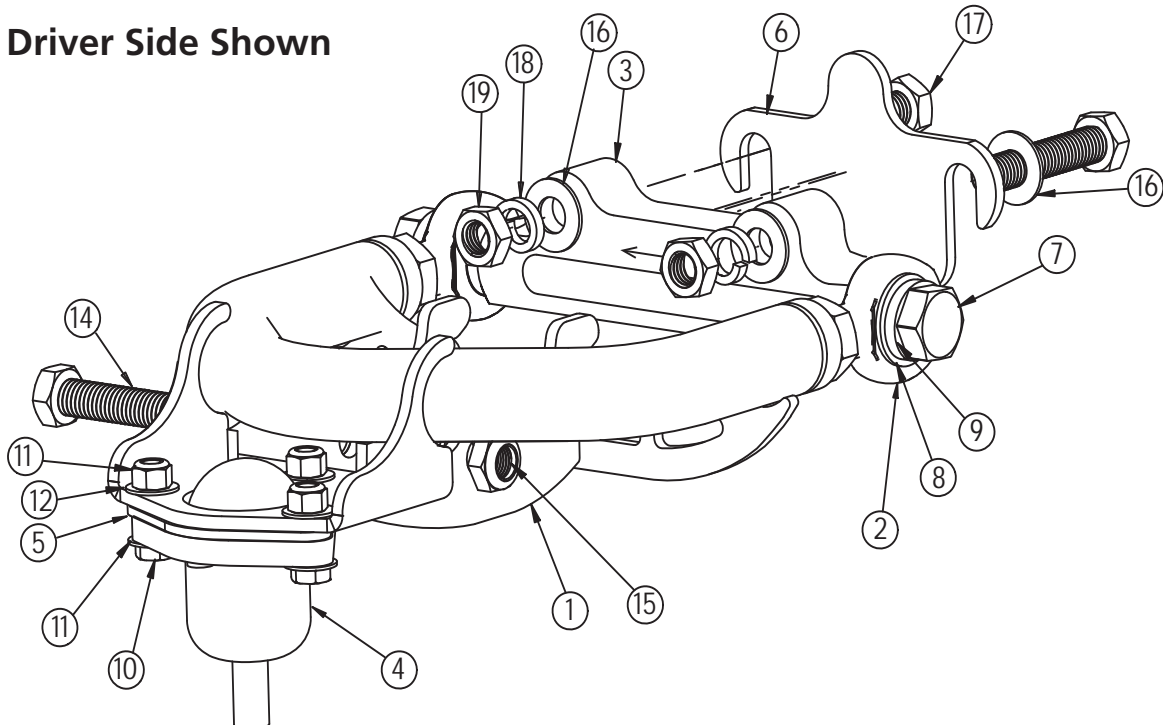

NOTE: DISCARD THE BALL JOINT NUT INCLUDED WITH THE BALL JOINT KIT. A NEW BALL JOINT NUT IS SUPPLIED IN THE HARDWARE KIT.



Lower Control Arm ComponentsIn the box

Item #	Part Number	Description	QTY
20	90003221	Driver Lower Control Arm (Shown)	1
21	90003222	Passenger Lower Control Arm	1
22	90003223	Strut Rod Frame Bracket Assembly	2
23	90003224	Frame T-Bushing	2
24	90001589	3/4" -16 x 5/8" Bolt Heim End - RH	2
25	90001591	3/4" -16 x 5/8" Bolt Heim End - LH	2
26	99752004	3/4" -16 Jam Nut - RH	4
27	99752006	3/4" -16 Jam Nut - LH	2
28	90002338	Frame Heim Spacer - 1/2" ID x 1.00" Long	4
29	90003225	Strut Rod Bracket Heim Spacer - 5/8" ID x .320" Long	4
30	90002582	Heim End Double Adjuster	2
31	90000898	Lower Ball joint - Proforged # 101-10013	2

Driver Side Shown

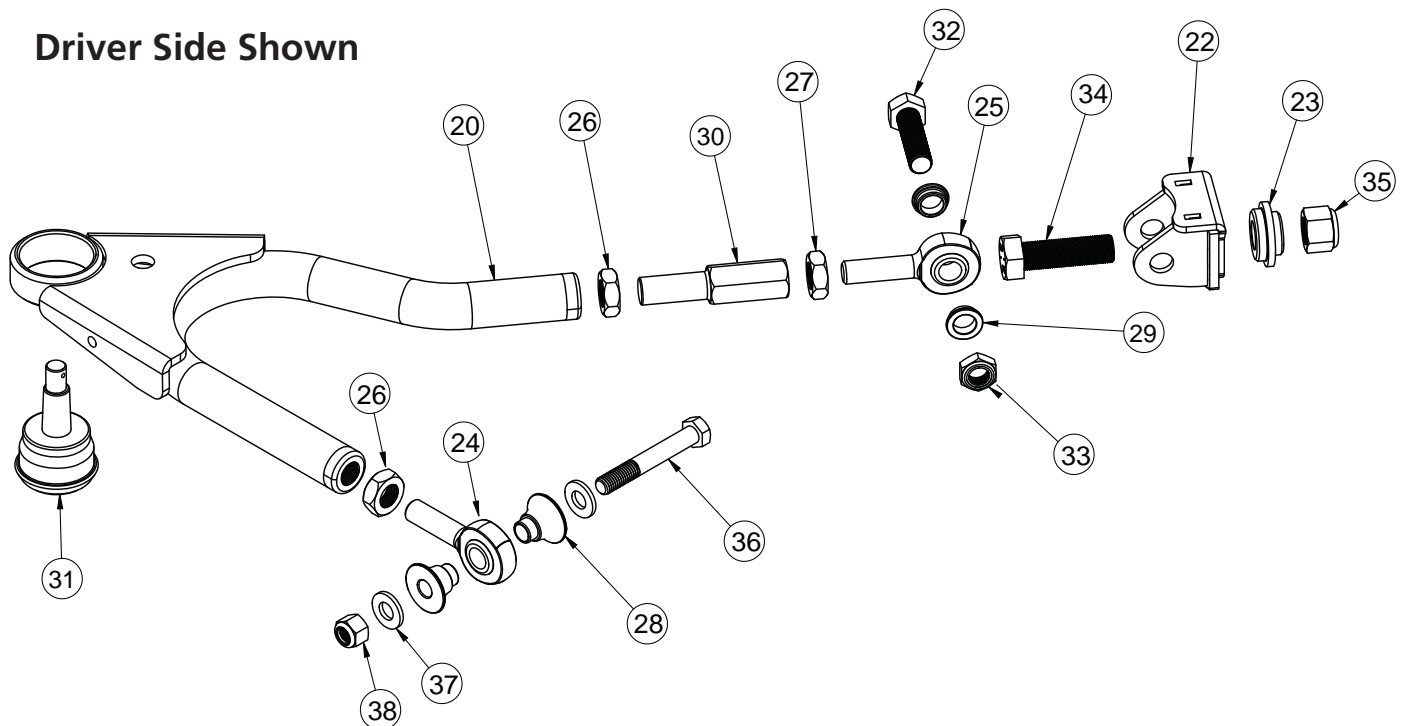



TruTurn Steering ComponentsIn the box

Item #	Part Number	Description	QTY
39	11009300	Ridetech Tall Spindle	1 pr
40	90002345	Drag Link Stud	2
41	90002351	Inner Tie Rod Stud	2
42	90002346	Tie-Rod Adjuster	2
43	90002347	Driver Steering Arm	1
44	90002348	Passenger Steering Arm	1
45	90002349	Bolt On Steering Stop - Driver	1
46	90002350	Bolt On Steering Stop - Passenger	1
47	90001582	Heim End - 5/8"-18 x 5/8" Bolt - RH Thread	2
48	90001590	Heim End - 5/8"-18 x 5/8" Bolt - LH Thread	2
49	90003219	Outer Tie Rod Stud	2
50	90003220	Outer Tie Rod Spacer - 5/8" ID x .375" BORGESON BOX ONLY	2
51	90002676	Outer Tie Rod Spacer - 5/8" ID x .125"	2
52	90003204	Centerlink Adapter	1
53	90003211	Offset Idler Mount - used with Borgeson Power Steering Box	1
54	90003205	Falcon Centerlink	1
55	90003206	Falcon Pitman Arm	1
56	90003207	Falcon Idler Arm Mount	1
57	90003055	Falcon/Mustang Idler Arm	1

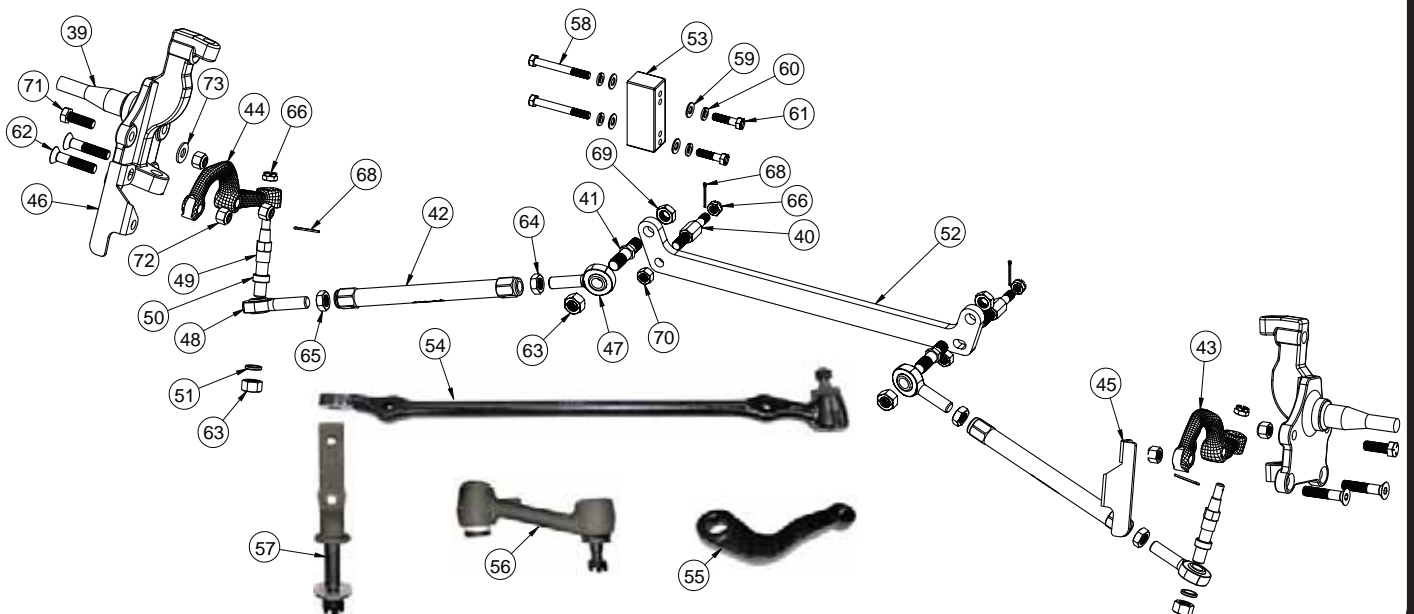



Hardware Shown in DiagramsKit# 99010151

ITEM #	Shock To Upper Control Arm		QTY	ITEM #	Idler Mounting Bracket To Mounting Block		QTY
14	99501005	1/2"-13 x 3 1/2" bolt GR8	2	59	99373002	3/8" SAE Flat Washer Gr8	2
15	99502009	1/2"-13 Nylok Nut GR8	2	60	99373006	3/8" Lock Washer	2
16	99503014	1/2" SAE Flat Washer GR8	4	61	99371007	3/8-16 X 1 1/2" Hex Bolt Gr8	2
Upper Control Arm To Car				Spindle To Steering Arm			
16	99503014	1/2" SAE Flat Washer GR8	8	62	99501054	1/2-20 X 2 1/2" Flat Head Socket Cap Screw	2
17	99501050	1/2"-13 x 2 1/2" bolt GR8	4	Steering Linkage			
18	99503015	1/2" SPLIT LOCK WASHER, GR8	4	63	99622003	5/8"-18 TOP LOCK NUT	4
19	99502021	1/2"-13 HEX Nut GR8	4	64	99800003	5/8"-18 RH Jam Nut	2
Upper Ball Joint To Spindle				65	99800002	5/8"-18 LH Jam Nut	2
	99502017	1/2"-20 Castle Nut	2	66	99432005	7/16"-20 Castle Nut	2
Heim End To Strut Rod Frame Bracket				67	99433002	7/16" SAE Flat Washer	2
32	99621031	5/8-18 X 2 1/4" Hex Bolt Gr8	2	68	99952002	3/32" Cotter Pin	2
33	99622006	5/8-18 Thin Nylok Nut	2	Draglink Adapter			
Strut Rod Frame Bracket To Car				66	99432005	7/16"-20 Castle Nut	2
34	99751005	3/4-16 X 2" Hex Bolt Gr8	2	67	99433002	7/16" SAE Flat Washer	4
35	99752001	3/4-16 Nylok Nut Gr8	2	68	99952002	3/32" Cotter Pin	2
Lower Control Arm To Car				69	99622005	5/8"-18 THIN mechanical locking nut	2
36	99501005	1/2-13 X 3 1/2" Bolt GR8	2	70	99502010	1/2"-20 Mechanical Locking Nut	2
37	99503001	1/2" SAE Flat Washer	4	Steering Stop			
38	99502001	1/2-13 Nylok Nut	2	71	99501053	1/2"-13 x 1 1/2" Hex Bolt GR8	2
Frame To Idler Mounting Block				72	99502009	1/2"-13 Nylok Nut GR8	2
58	99371067	3/8-16 X 3 1/4" Hex Bolt Gr8	2	73	99503014	1/2" SAE Flat Washer GR8	2
59	99373002	3/8" SAE Flat Washer Gr8	2				
60	99373006	3/8" Lock Washer	2				

Getting Started.....

Congratulations on your purchase of the Ridetech TruTurn System. This System has been designed to give your Falcon excellent handling along with a lifetime of enjoyment. Some of the key features of the TruTurn System: Ball joint angles have been optimized for the lowered ride height, eliminated rubber bushings to get rid of bushing deflection and provide free suspension movement through the entire range of travel. The geometry has been optimized for excellent handling, driveability and minimal bump steer.

Note: These control arms are designed for use with the Ridetech CoilOvers and the MuscleBar swaybar. **The factory shocks and springs or the factory sway bar will not fit these arms.**

Mini-Starter required to clear TruTurn Centerlink Adapter (not Included).

Ridetech offers a **V8 only** crossmember brace to help strengthen the front end of our Falcon. Part # **12289550**

Brake Kits

The Falcon TruTurn Suspension package uses a GM Spindle used on 67-69 F body, 64-72 A body, and 68-74 X body. Any brake kit designed for this spindle will work. It just **needs a 4 1/2" on 5 bolt pattern** to keep the same bolt pattern as the rear of the Falcon.

We collaborated with Baer and Wilwood to develop brake kits that work in harmony with our suspension. Depending on wheel size and your braking needs, both Wilwood and Baer have brake kits that will work with your car. Please visit our website to review options for your application.

1. Remove the entire front suspension from the car including the centerlink, idler arm, and pitman arm. Refer to a Factory Service Manual for the proper method. The control arms, spindles, and steering linkage will all be replaced with the TruTurn package.



Installing Strut Rod T-Bushing

2.

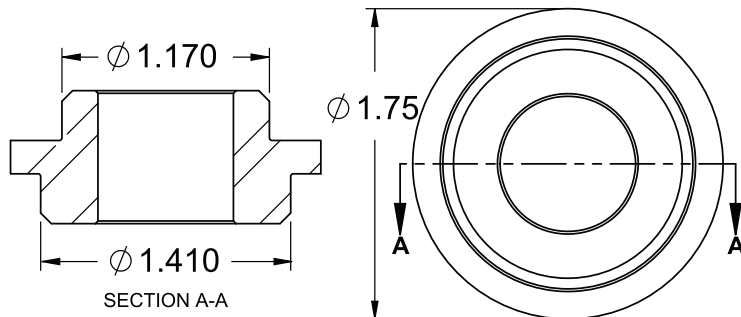

2. This kit includes a t-bushing for the strut rod bushing factory hole. The factory hole can be 2 different diameters depending on the year of the car. The size of your frame hole will determine which direction the t-bushing is installed.

3.



3. Test fit the t-bushing in your car's strut rod mount to help determine which direction it needs to be installed. The t-bushing is installed from the front side of the car.

4.



4. Insert 3/4\"-16 x 2\" bolt in the strut rod frame bracket. The head of the bolt needs to be on the side of the bracket with the 2 mounting ears.



Installing Lower Control Arm



5. With the 3/4"-16 x 2" bolt installed in the bracket, attach the bracket to the front heim of the control arm with the flat side of the bracket on the same side as the ball joint pin. The bracket is installed with a 5/8" ID x .320" spacer on each side of the heim. The spacers need to be installed with the small outside diameter against the heim end. Align the holes of the bracket with the through holes of the spacers and heim. Install a 5/8"-18 x 2 1/4" bolt through the aligned holes. Install a 5/18"-18 thin nylok nut on the threads of the bolt and torque to 45 ftlbs.



6. Insert the 3/4" bolt of the strut rod adapter bracket through the center hole of the t-bushing. The t-bushing and threads of the bolt should be to the front of the car.



7. Install a 3/4"-16 nylok nut on the threads of the bolt sticking through the t-bushing. Torque to 120 ftlbs.



Installing Lower & Upper Control Arm



8. Install the 2 aluminum spacers into the rod end that goes into the factory control arm pivot. Slip the control arm into the factory frame mount.



9. Align the factory holes with the control arm through hole. Install a 1/2" flat washer on a 1/2"-13 x 3 1/2" hex bolt. Insert the bolt/washer through the aligned holes. Install a 1/2" flat washer and 1/2"-13 nylok nut on the threads of the bolt. Torque to 75 ftlbs.



10. Bolt the upper StrongArm to the body using 1/2"-13 x 2 1/2" bolts, flat washers and lock washers. The ARROW points to the front of the vehicle. A shim is supplied and may need to be installed between the body and the arms to achieve proper alignment. The arms are preset at the factory so the alignment should be close, but the vehicle must be aligned before driving.

Note: The upper arm mounting holes on many cars have been redrilled 1" lower. This is done to improve the handling. Our cross shaft has the drop built into it; **make sure to use the factory mounting holes.**



Upper Control Arm & Spindle Installation



11. Install a 1/2" flat washer, 1/2" split lock washer, and 1/2"-13 nut on the threads of the 2 bolts sticking through into the engine compartment. Torque to 75 ftlbs.



12. Install the spindle on the lower ball joint pin. Torque the ball joint castle nut to 65 ftlbs and tighten to align the cotter pin holes. Install the cotter pin in the ball joint pin hole and bend the ends of the cotter pin to hold it in place. Install the grease zerk supplied with the ball joint.



13. DISCARD THE BALL JOINT NUT THAT IS SUPPLIED IN THE BALL JOINT KIT. A NEW 1/2"-20 CASTLE NUT IS SUPPLIED IN THE HARDWARE KIT. Install the spindle on the upper ball joint pin. THREAD THE 1/2"-20 CASTLE NUT SUPPLIED IN THE HARDWARE KIT ON THE THREADS OF THE BALL JOINT PIN. Torque the ball joint castle nut to 50 ftlbs and tighten to align the cotter pin holes. Install the cotter pin in the ball joint pin hole and bend the ends of the cotter pin to hold it in place. Install the grease zerk supplied with the ball joint.



Installing Idler Arm - Stock Steering Box



14. Remove the idler arm that is currently installed on the car. Your current idler arm may have 3 mounting holes, but there is a 2 hole bolt pattern under it. The idler arm supplied with the kit will use the 2 mounting holes circled in **Image 14**.

IF YOU HAVE A BORGESON STEERING BOX ON YOUR FALCON, SKIP TO STEP 16!



15. Attach the new idler arm using the OEM hardware. **Skip to Step 19.**

Installing Idler Arm - Borgeson Power Steering Box



CARS WITH BORGESON POWER STEERING BOX ONLY!!

16. If using a Borgeson steering box, the idler arm needs to be lowered to optimize the steering geometry. The kit includes a spacer block to do this. The spacer block has 2 sets of mounting holes, but each set is only threaded on one side. The idler arm needs to bolt to the set of holes closest to the edge of the spacer block. See **Image 16**.



Installing Idler Arm - Borgeson Power Steering Box



17. The idler mount is attached to the spacer block using (2) 3/8" 16 x 1/2" hex bolts, (2) 3/8" split lock washers, and (2) 3/8" SAE flat washers. Install a 3/8" split lock washer followed by a 3/8" SAE flat washer on each bolt. Line up the idler mount with the bolt pattern the will position it closest to the edge of the spacer block. The idler mount needs to be positioned so the offset positions the pivot under the spacer block. See **Image 17**. Line up the mounting holes with the threaded holes of the spacer block and thread in the bolt/washers into each mounting hole. You can torque these after it is installed on the car.



18. The idler/spacer is attached to the car using (2) 3/8"-16 x 3 1/4" hex bolts, (2) 3/8" split lock washers, and (2) 3/8" SAE flat washers. Install a 3/8" split lock washer followed by a 3/8" SAE flat washer on each bolt. Insert the bolt/washers into the mounting holes circled in Step 14. Thread the bolts into the 2 top holes of the spacer block. Torque all the 3/8" bolts to 35 ftlbs.



19. Install the idler arm on the idler mount with the pin pointing up. Position the pin of the idler to the front of the car before torquing the castle nut. Torque the castle nut to 35-47 ftlbs and tighten to align the cotter pin hole. Install the cotter pin and bend the ends.



Installing Pitman Arm & Centerlink



20. The TruTurn kit includes a new pitman arm. A pitman arm puller is necessary to replace the pitman arm. Remove the OEM pitman arm using a pitman arm puller. If you do not have one, they can usually be rented from your local auto parts store. Install the new pitman arm using **Image 20** as a reference. The large diameter of the centerlink pin taper should be down toward the ground. Torque the nut 85-110 ftlbs.-+



21. Attach the new centerlink in the pitman arm. The centerlink only has a tapered pin on one end, it goes into the pitman arm. Torque the nut of the centerlink pin to 35-47 ftlbs and tighten to align the cotter pin hole. Install the cotter pin and bend the ends.



22. The other end of the centerlink will sit down on the stud of the idler arm. Install the end of the centerlink on the stud and torque the castle nut to 25-30 ftlbs. Tighten the nut to align the cotter pin. Install the cotter pin and bend the ends.



Centerlink Adapter Installation



23. The studs with the long hex on them will get installed into the factory centerlink with the taper going into the centerlink, a 7/16" castle nut is used to attach it to the centerlink. The straight shank will point to the front of the car.

Note: It may be necessary to install 7/16" washers under the castle nut to get the cotter pin engaged properly.



24. Torque the nuts to 35 ftlbs and tighten as needed to align cotter pin. Install cotter pin and bend the ends.

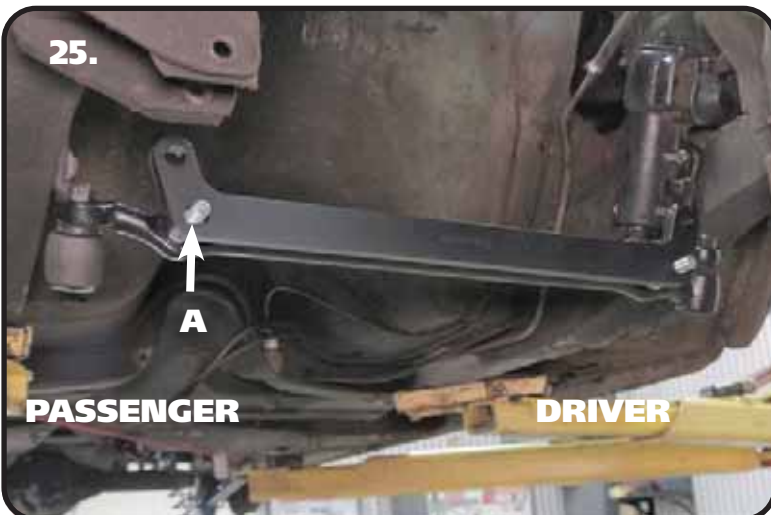

25. The centerlink bracket has one attachment hole [A] that is slotted. This is to accommodate the variations in manufacturing and machining processes, as well as any wear that may have occurred to the original centerlink over time. The slot goes on the passenger side centerlink adapter stud.



Centerlink Adapter Installation

26.



26. Install the 1/2"-20 mechanical locking nuts and torque to 50 ftlbs.

27.



27. The studs with the short hex get installed into the centerlink adapter. The short side goes into the adapter attached with the 5/8"-18 thin top lock nut, with the long side of the stud pointing forward.

28.



28. Install the 5/8"-18 **THIN** mechanical locking nut on the threads of the stud sticking through the centerlink adapter and torque to 45 ftlbs.



Steering Arm & Stop Installation

29a.

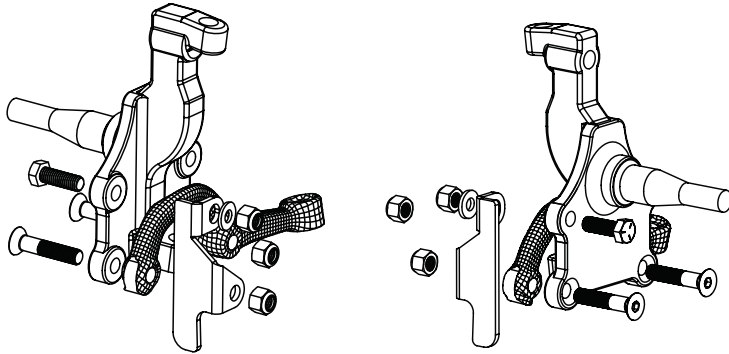

PASSENGER

DRIVER

29a. Install the steering arms and steering stops onto the spindle using **Images 29a & 29b** as a reference. The steering arms angle toward the centerlink, and the tie rod mounting holes are to the rear of the car. The steering stops are marked D and P.

The steering arm is attached to the spindle using 1/2"-20 x 2 1/2" flat socket cap bolts and nylok nuts. Torque to 100 ftlbs.

The upper tab of the steering stop is attached to the spindle using 1/2"-13 x 1 1/2" hex head bolt, 1/2" SAE flat washer, and Nylok. Torque to 75 ftlbs.

29b.

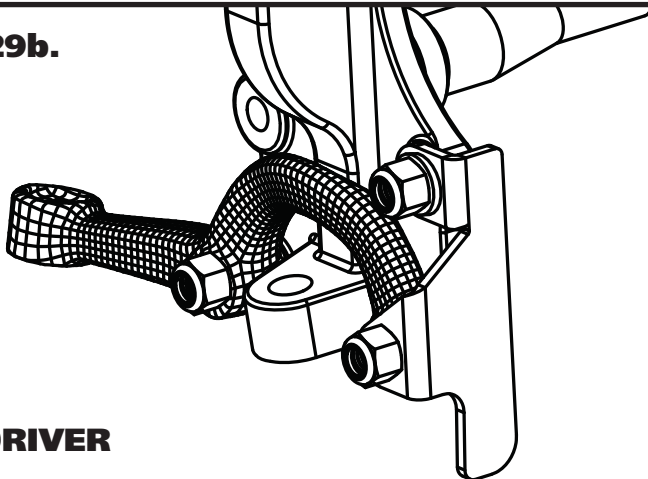

DRIVER

29b. You will notice in **Image 29b**, the bottom hole of the steering stop is mounted on top of the front steering arm mounting hole. The top mounting tab of the steering stop is on the engine side of the spindle.

30.



30. Install the stud with the round flange into the steering arm with the taper going into the steering arm. Torque the nuts to 35 ftlbs and tighten as needed to align cotter pin hole and install cotter pin.



Tie Rod Assembly & Installation

31.

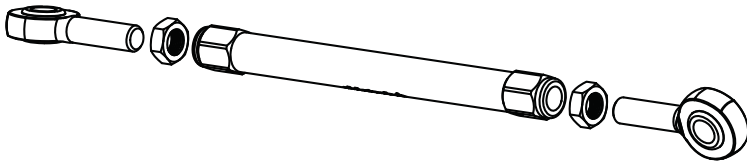

31. The tie rod adjuster has 2 threads in it; 5/8"-18 RH & 5/8"-18 LH. The 5/8"-18 LH thread is marked with a groove on the outside of the adjuster. The tie rod can now be assembled to a center to center length of xx xx" to start with, having equal amount of threads on both ends. These aluminum adjusters have a left hand thread on one end and a right hand thread on the other. You should use anti seize when threading the heim ends into the adjuster. **FOR YOUR SAFETY, THE TIE ROD & HEIM NEED A MINIMUM OF 15/16" OF THREAD ENGAGEMENT INTO THE TIE ROD ADJUSTER.**

32.



32. Install one end of the tie rod onto the stud of the centerlink adapter. Install a 5/8"-18 mechanical locking nut on the threads of the stud and torque to 45 ftlbs.

IF YOU HAVE A BORGESON STEERING BOX ON YOUR FALCON, SKIP TO STEP 34!

33.



33. **STOCK STEERING BOX ONLY!** Install the outer end of the tie rod on the steering arm stud. Skip to Step 35.



Tie Rod Installation



CARS WITH BORGESON POWER STEERING BOX ONLY!!

34. Install a 5/8" ID x 3/8" spacer on the steering arm stud, followed by the outer end of the tie rod.



35. Install the 5/8" ID x .125" spacer on the stud followed by a 5/8"-18 mechanical locking nut. Torque to 45 ftlbs.

36. Double check that you have tightened all hardware to the proper torque. If you are going to install the Ridetech MuscleBar, now is a good time to do it.

Suggested Alignment Specs:

Camber: Street: -.5 degrees
Caster: Street: +3.0 to + 5.0 degrees
Toe: Street: 1/16" to 1/8" toe in