

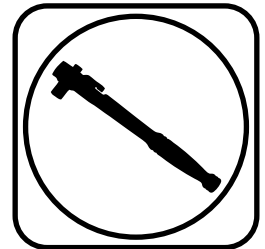

**Part # 12293699 - 2015-Up Ford F150 HQ Upper Control Arms**

### Recommended Tools



## 2015-Up Ford F150 Front Upper Control Arms Installation Instructions

### Table of contents

- Page 2..... Included Components
- Page 3..... Disassembly and Installation
- Page 4..... Installing Upper Control Arm

**IF INSTALLING COILOVERS, INSTALL THEM IN CONJUNCTION WITH THE UPPER CONTROL ARMS.**

***IF YOU ARE INSTALLING THIS KIT ON A 2021+ WITH HEADLIGHT SENSORS, YOU WILL ALSO NEED KIT # 12299501.***

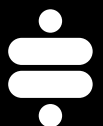



### Major Components .....In the box

Item #	Part #	Description	QTY
1	90003266	Upper Control Arm - Driver	1
2	90003267	Upper Control Arm - Passenger	1
3	90003269	Upper Control Arm Bushings - Tenneco # MB05B714620	4
4	90003268	Upper Control Arm Ball Joint - Moog # K6696	2
5	70015619	Upper Ball Joint Dust Cap	2
6	90002283	Ball Joint Nut Spacer	2

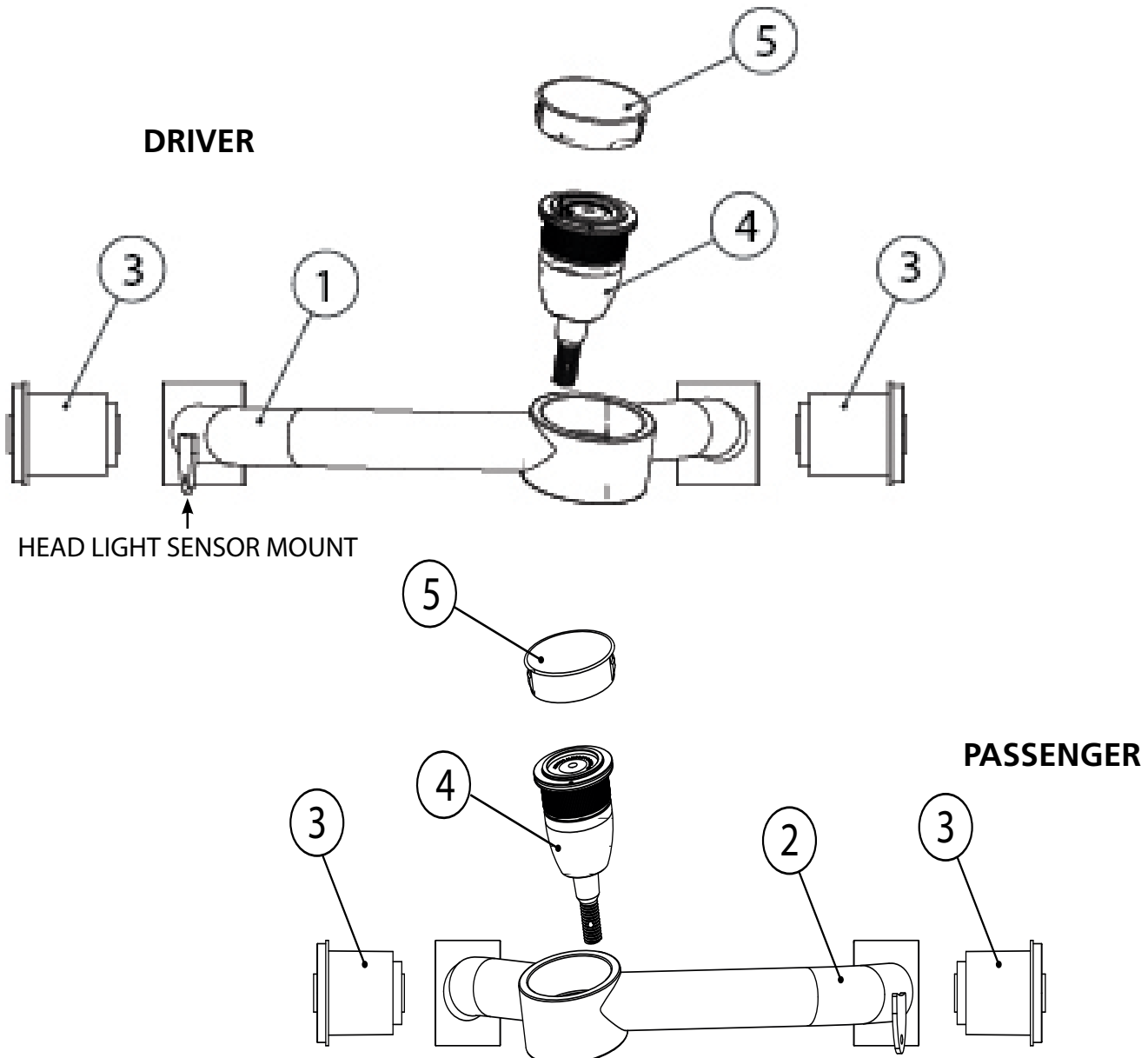



### Disassembly

1. Block the rear wheels of the truck to prevent it from rolling.
2. Raise the front of the truck and support it by the frame, allowing the suspension to hang freely.
3. Remove the wheels.
4. Remove the OEM upper control arm. Retain the hardware to install the new upper control arm. **2021 or newer F150 trucks will require the headlight sensor linkage to be disconnected from the upper control arms.**
5. If installing with Ridetech Coilovers, install the coilovers at this time. Follow instructions included with the coilovers.

### Installation

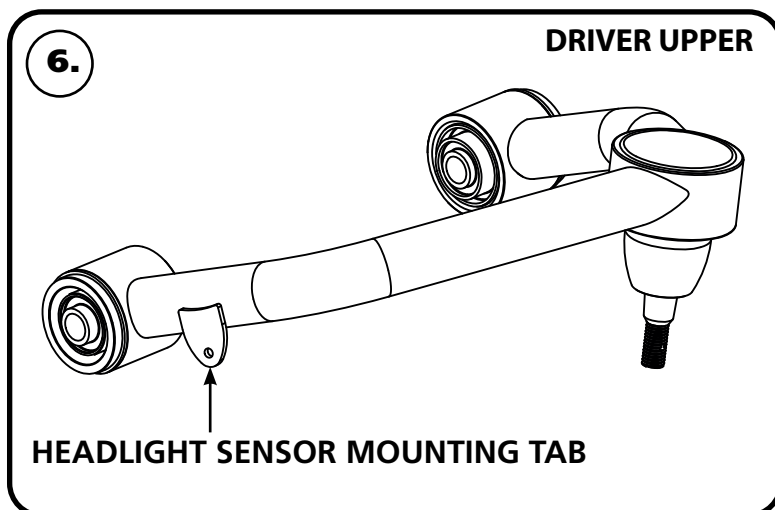

6. The upper control arm has a headlight sensor tab on the front tube. The headlight sensor is only on 2021 & up model year trucks.



7. Install the Ridetech upper control arms using the OEM hardware. The headlight sensor tab should be to the front of the truck. If installing controls arms on a 2021+ F150, reattach the headlight sensor linkage to the tab of the control arm. The control arm mounting bolts will need to be tightened after the truck is sitting on the ground.



### Installing Upper Control Arm



**8.** Insert the ball joint stud into the spindle. Install the flat washer supplied with the ball joint nut. Next, install the ball joint nut and torque to 50 ft-lbs. Tighten the nut until a slot in the nut aligns with the hole in the ball joint pin. **NEVER LOOSEN THE NUT TO ALIGN THE HOLE!**

**NOTE:** Some years of trucks will require a spacer under the ball joint nut to get proper alignment of the castle nut with the cotter pin hole. If the cotter pin hole is above the castle nut, the spacer will need to be installed under the castle nut.



**9.** Install the supplied cotter pin. Bend the tabs of the cotter pin.

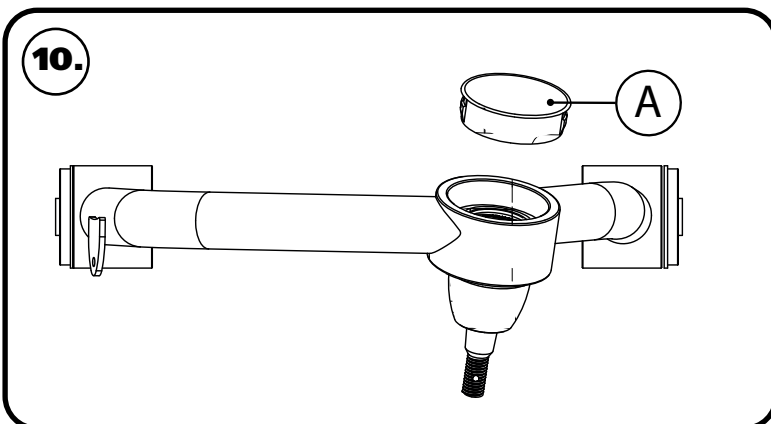

**10.** Insert the grease zerks in the ball joints. Grease the ball joints and install the supplied caps(A). These caps will help keep debris out of the control arms.

**11.** Reinstall wheels and torque lug nuts to factory specifications.

**12.** Lower the vehicle to the ground and torque upper control arm hardware to 111 ft-lbs.

**13.** Recheck hardware after 500 miles.

**14.** Remove the cap and grease the ball joint at regular service intervals.