



### Part # 12294050 - 2015-Up Ford F150 Helper Air Springs



#### Recommended Tools



## 2015-Up F150 Helper Air Springs Installation Instructions

### Table of contents

- Page 2..... Air Spring Kit Components
- Page 3..... Hardware List & Getting Started
- Page 4-6..... Installation

THIS AIR SPRING KIT IS DESIGNED TO BE USED WITH RIDETECH'S REAR LOWERING KIT.





### Air Spring Kit Components .....In the box

Item #	Part Number	Description	QTY
1	90007076	4" Diameter Rolling Sleeve Air Spring	2
2	90003287	Driver Upper Frame Bracket	1
3	90003288	Passenger Upper Frame Bracket	1
4	90003289	Lower Spring Bracket	2
5	90003297	Air Spring Roll Plate	2
6	90003290	Nut Plate	4
7	31952201	1/8" NPT x 1/4" Tube 90 Degree Fitting	2
8	31954400	1/4" Tube T fitting - NOT SHOWN	1
9	31957005	1/4" Tube Inflation Valve - NOT SHOWN	1
10	31940003	1/4" Air Line by <b>foot</b> - NOT SHOWN	15

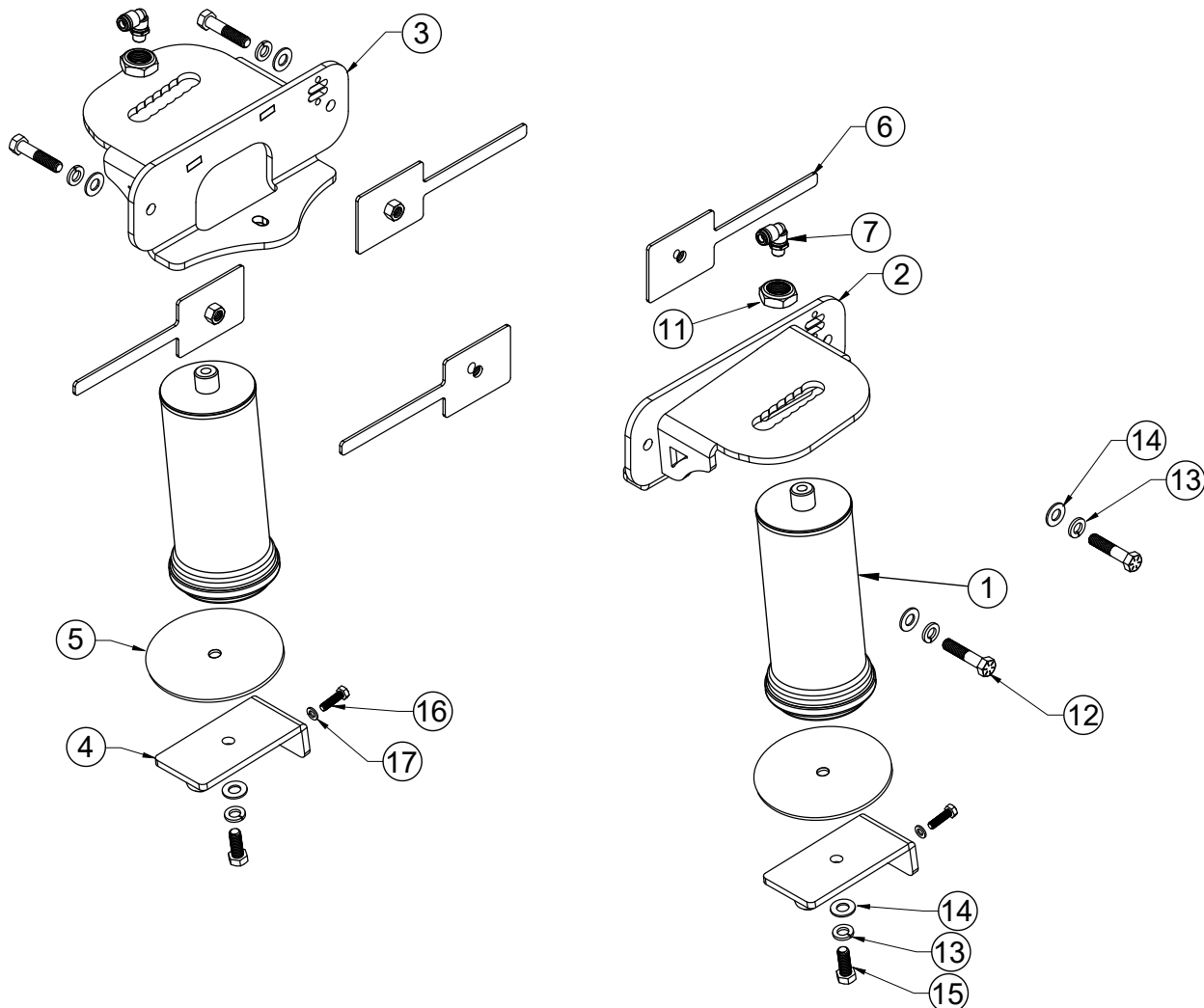



### Hardware List .....In the box (Kit# 99010172)

The Hardware Kit contains bags to help aid in selecting the correct hardware for the component being installed. The hardware list shows how the hardware is bagged.

Item #	Part Number	Description	QTY	Item #	Part Number	Description	QTY
<b>AIR SPRING TO UPPER MOUNT</b>				<b>AIR SPRING TO LOWER MOUNT</b>			
11	99752004	3/4"-16 Thin Jam Nut	2	13	99373006	3/8" Split Lock Washer	2
<b>UPPER MOUNT TO FRAME</b>				14	99373002	3/8" SAE Flat Washer	2
12	99371024	3/8"-16 x 1 3/4" Hex Bolt	4	15	99371005	3/8"-16 x 1 1/4" Hex Bolt	2
13	99373006	3/8" Split Lock Washer	4	<b>LOWER AIR SPRING MOUNT TO SPRING PERCH</b>			
14	99373002	3/8" SAE Flat Washer	4	16	99081009	M8-1.25 X 30 Hex Bolt	2
	90002263	Red Loctite		17	99013001	M8 Flat Washer	2

### Getting Started.....

This kit is designed to be used with the Ridetech F150 rear lowering kit. The rear lowering kit needs to be installed before the air spring kit can be installed.



1. Remove the bump stops from the OEM location. It will be reinstalled to help hold the upper air spring mount in place.



2. Remove the brake line bracket bolt from the rear of the leaf spring pads.



### Installation

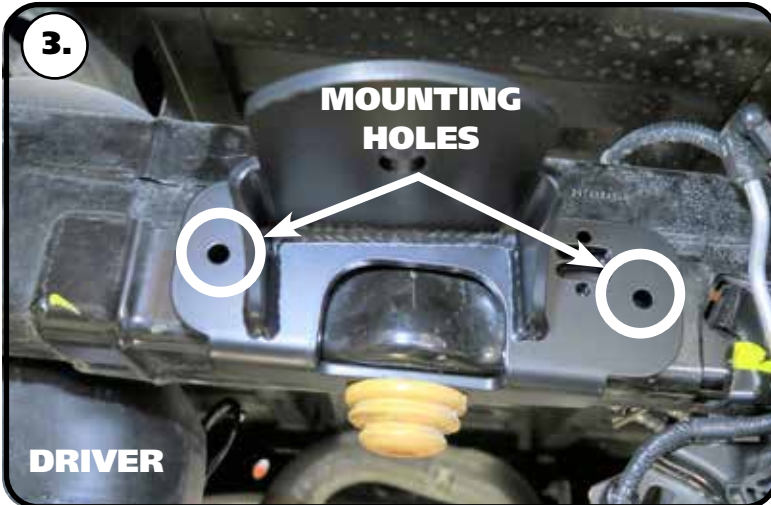

**3.** Position the upper air spring mount in place over the OEM bumpstop hole. The air spring mount is positioned with the ICON to the rear of the truck. The Driver side is shown in **Image 3**. Reinstall the bumpstop to hold the upper air spring mount in place.



**4.** The kit includes (4) nut plates to be used to attach the upper mounts. The nut plates have a handle made into them that can be BENT to help position the nut plate. Each upper mount uses (2) nut plates to hold it in place. The nut plates are inserted through the large hole in the inner frame rail. The large hole is right behind the air spring mount. We found bending the nut plate handle at a 90 degree angle about half way up the handle works well. The handle needs to be bent toward the nut side of the plate. The flat side will go against the frame



**5.** Install a 3/8" split lock washer & 3/8" SAE flat washer on each of (2) 3/8"-16 x 1 3/4" hex bolts. Apply Red Loctite to the threads of each bolt. Insert the bolts into each mounting hole in the side of the upper air spring mount. Thread each bolt into a nut plate. Torque the bolts to 30 ft-lbs.



### Installation

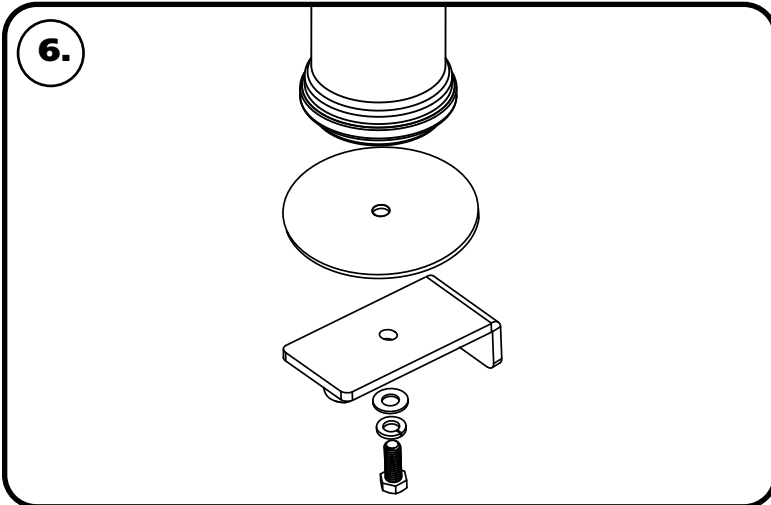

6. Attach the roll plate and lower air spring mount to the bottom of the air spring using a 3/8"-16 x 1 1/4" bolt, 3/8" split lock washer, & 3/8" SAE flat washer. Torque to 23 ft-lbs. Repeat for the 2nd air spring, roll plate, & mount.



7. Insert the air spring into position with the upper mounting stud through the 3/4" hole in the upper mount. The long tab of the lower mount will go against the rear of the leaf spring mount of the axle.

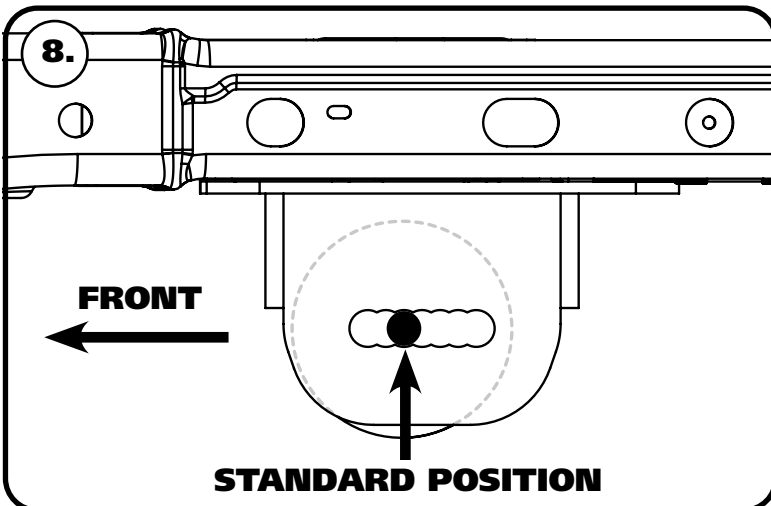

8. The upper air spring mount has multiple mounting positions to help optimize the air spring alignment. The standard mounting position is the 3rd notch from the front. Ideally, you want the upper and lower mounting bolts lined up with each other as well as possible at ride height.



### Installation



**9.** Insert the mounting stud of the air spring into the standard position, but do NOT install the nut at this time.



**10a. & 10b.** The lower mount gets attached with the M8-1.25 x 30mm & M8 flat washer supplied with the kit. **10a** is 2015-2020 F150, it has no headlight sensor. **10b** is 2021 F150 WITH a headlight sensor on the driver side. Align the rear tab of the lowering mount with the mounting hole in the leaf spring mount. Install the M8 flat washer on the M8-1.25 x 30 mm bolt and thread it into the OEM mounting hole. Torque to 169 in-lbs.



**2021 F150 DRIVER SIDE**



### Installation



**11.** Verify the top and bottom of the air spring are in line with each other. If not, move the top forward or backward to get them as close as possible. Thread the 3/4"-16 jam nut on the upper stud of the air spring. Torque the nut to 350-400 in-lbs.

**12.** Put thread sealant on the 90 degree air fittings and thread them into the top of each air spring and tighten.

**13.** Establish a location for the inflation fitting and run the air lines. The air springs will get hook together with the supplied "t" fitting. Cut the air line with a razor blade, making sure the cut is straight. Keep the airline at least 6" from any heat source.

**14.** After putting the truck back on the ground, you will need to put air in the air springs to make them take shape. It can take 30-40 psi in the air springs to make them straighten out. After they straighten out, reduce the air pressure back down to 15 psi (or whatever air pressure is needed to offset the current load).

**ALWAYS KEEP A MINIMUM OF 15 PSI IN THE AIR SPRINGS TO PREVENT DAMAGE TO THE AIR SPRINGS.**