



**Part # 12299122 - 2015-Up Ford F150 Rear Sway Bar**

### Recommended Tools



## 2015-Up- Ford F150 Rear Sway Bar Installation Instructions

### Table of contents

Page 2.....	Included Components
Page 3.....	Hardware List & Getting Started
Page 4-8.....	Sway Bar Installation
Page 8.....	Final Tightening

**THIS SWAY BAR IS DESIGNED TO BE USED WITH THE REAR LOWERING KIT.**

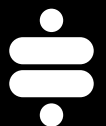





### Hardware Kit .....# 99010171

Item #	Part #	Description	QTY
<b>U-BOLT</b>			
13	99432007	7/16"-20 Nylok Nut	4
14	99433005	7/16" SAE Flat Washer	4
<b>SWAY BAR BRACKET TO FRAME</b>			
15	99501004	1/2"-13 X 3" Hex Bolt	2
16	99503015	1/2" Split Lock Washer	2
	90002263	Red Loctite	1

### Getting Started.....

**Note:** This sway bar kit utilizes a anti-friction lining in the sway bar bushing. The lining allows the sway bar to move freely and quietly in the bushing. No lubrication is required.

#### THIS SWAYBAR ATTACHES TO THE AXLE AND FRAME.

1. Jack the vehicle up to a safe working height and support with jack stands. Make sure the jack stands are stable before working under the truck.
2. The rear flip kit needs to be installed before the rear sway bar.

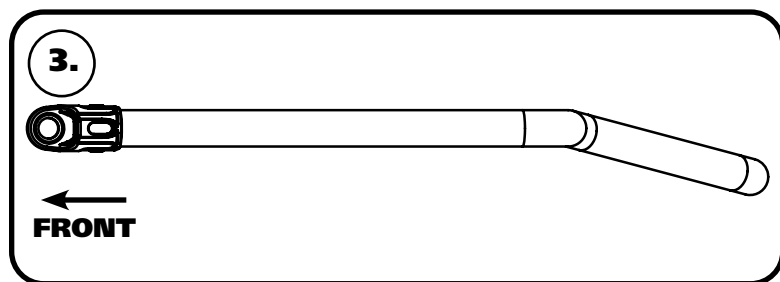

**3. Diagram 3** shows how the sway bar will be positioned on the rear differential.



**4.** Open the sway bar bushing at the split and slip it **OVER** the sway bar. Do this for both bushings.



### Sway Bar Installation



5. Install the bushing straps over the sway bar bushings.



6. The gas tank/shock crossmember will need to be drilled to attach the frame mount. We use the rear of the frame slot as a guide. Drill the crossmember straight above the frame slot using a 1/2" drill bit.

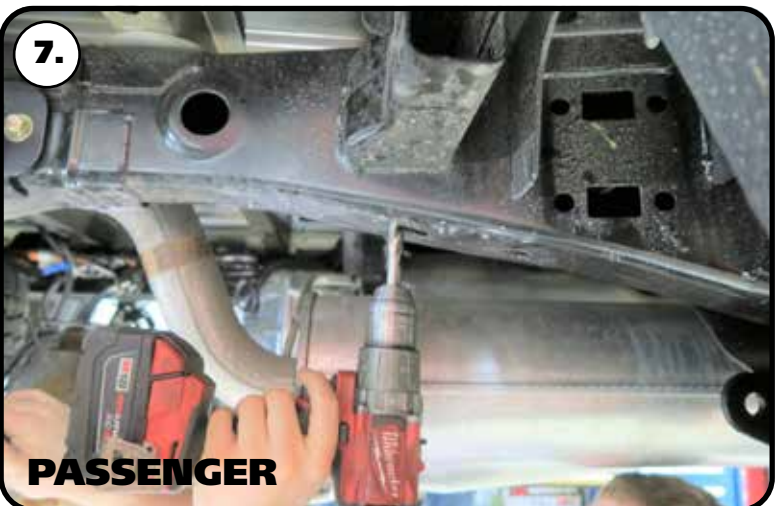

7. Drill the passenger side shock crossmember using a 1/2" drill bit. We use the back edge of the frame slot as a guide. Drill the whole straight up from the rear of the frame slot.



### Sway Bar Installation



8. The frame mount will get attached to the frame using a 1/2"-13 x 3" bolt, 1/2" split lock washer, red loctite, and a nut plate. The frame mounts are the same for driver and passenger, but the nut plate are different. The frame mount has a tab that will index of the inside of the frame rail. Install a 1/2" split lock washer on a 1/2"-13 x 3" hex bolt and insert it into the frame mount. Apply red loctite to the threads of the bolt. Slip the SHORT nut plate into the driver crossmember. Position the frame mount on the frame with the 1/2" bolt inserted through the drilled hole and the frame tab on the inside of the frame rail. Thread the bolt into the nut plate and torque to 75 ft-lbs.



9. Repeat the above steps on the passenger side using the LONG nut plate to hold the frame mount.



10. Install a 7/16" u-bolt on the driver side axle tube just to the outside of the brake line mount.

**NOTE:** You may have to pull the wiring harness to the side slightly to allow the U-bolt to pass through. The harness should settle back to its original position once the U-bolt is in place.



### Sway Bar Installation

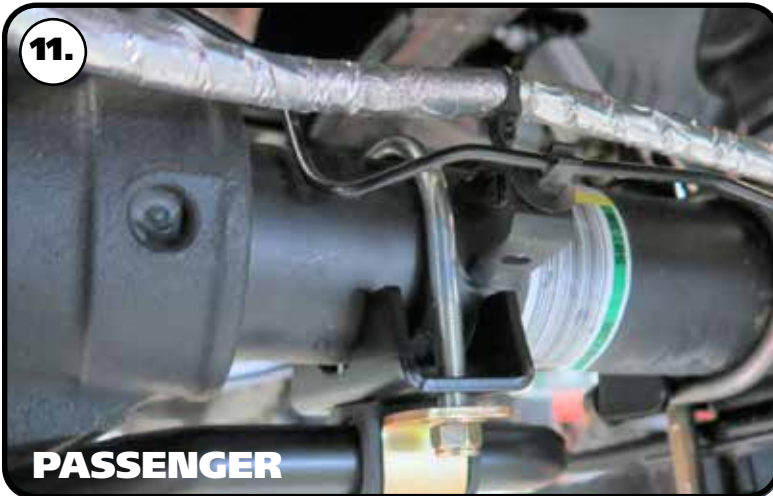

**11.** Install a 7/16" u-bolt on the passenger side axle tube just to the inside of the brake line bracket.

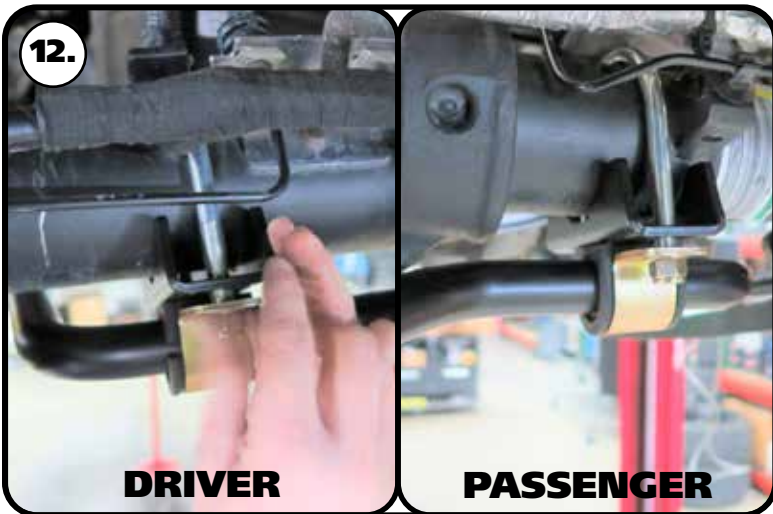

**12.** Hold the sway bar in position on the truck with the center bend toward the ground. Install a 7/16" Flat Washer & 7/16"-20 Nylok Nut on the threads of the u-bolts. The axle mounts should be positioned parallel with the leaf springs. Snug the hardware down and verify the axle mounts are parallel with the leaf springs. Torque the u-bolt hardware to 35 ft-lbs.

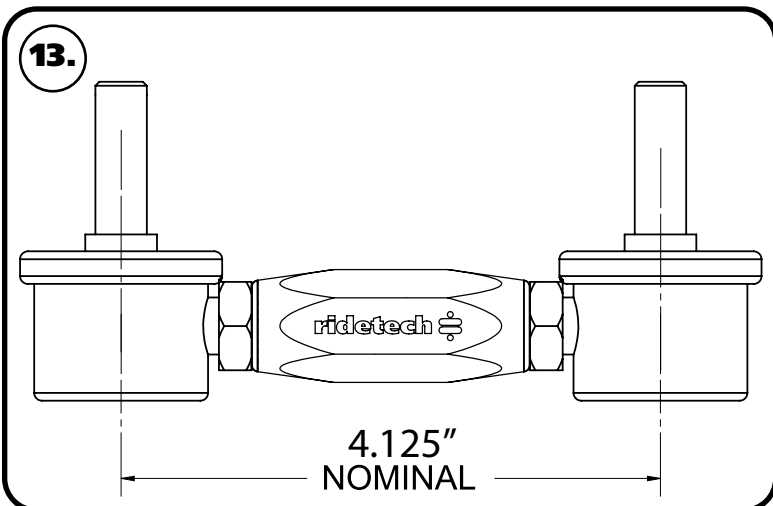

**13.** Set the Linkage to 4 1/8" center to center with the threaded studs pointed the same direction. Snug the jam nuts against the center adapter. Use **Diagram 13** as a reference.



### Sway Bar Installation



**14.** Attach the linkage to the frame bracket with the threads of the end link pointing outward. Use the hardware on the linkage to attach it. Torque the nut to 37 ft-lbs. Repeat on the other side.



**15.** Install a T-Bushing on each of the bottom 90 degree end links. The t-bushings are installed with the large diameter against the shoulder of the end link. Insert the 90 degree end link/t-bushing into the swaybar end with the threads pointing outward.



**16.** Install a 2nd t-bushing with the small diameter into the swaybar. Install the nut and torque to 37 ft-lbs. Do this for both sides.



### Sway Bar Installation



**17.** Install the locking rings on the inside of each bushing assembly. Use a hex key to take the locking ring apart. Reassemble it on the bar positioned next to the inside of the bushing assembly. Push the locking ring up against the bushing assembly and tighten.

### Final Tightening

**18. DOUBLE CHECK THE HARDWARE TO MAKE SURE IT IS TIGHT.**