

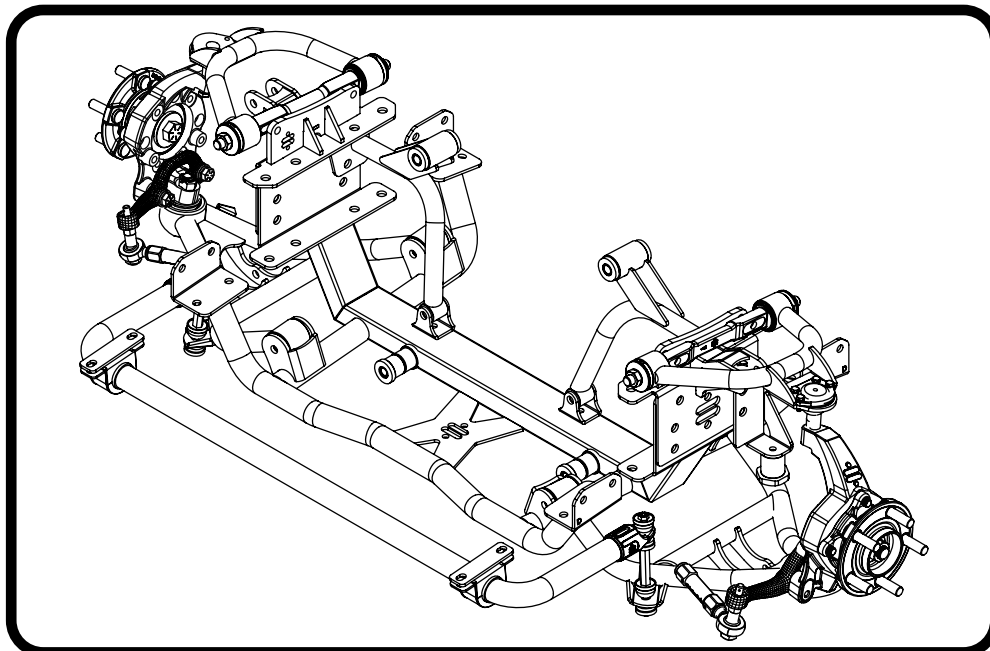

12312798

1965-1979 Ford F100 Front Suspension System w/ Hub Bearing Spindle



Recommended Tools

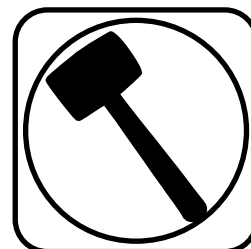
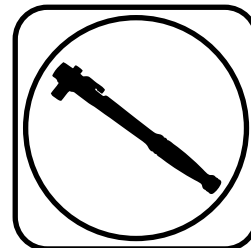

65-79 Ford F100 Front Suspension Installation Instructions

Table of contents

Page 2-3.....	Component Assemblies
Page 4-9.....	Included Components & Lists
Page 10.....	Important Notes
Page 10-16.....	Disassembly
Page 16-21.....	Cradle Installation
Page 22.....	Lower Control Arm Installation
Page 23.....	Caster Explained
Page 24.....	Offset Upper Cross Shaft
Page 25.....	Upper Control Arm Installation
Page 26-27.....	Shock Installation
Page 28-29.....	Rack Installation
Page 29.....	Spindle Installation
Page 30-32.....	Caliper Bracket Installation
Page 33.....	Steering Arm Installation
Page 34-35.....	Steering Linkage Installation
Page 35-37.....	Sway Bar Installation
Page 38.....	Finishing and Alignment





Major Components AssembledIn the box

CRADLE ASSEMBLY

Exploded View on Page 5

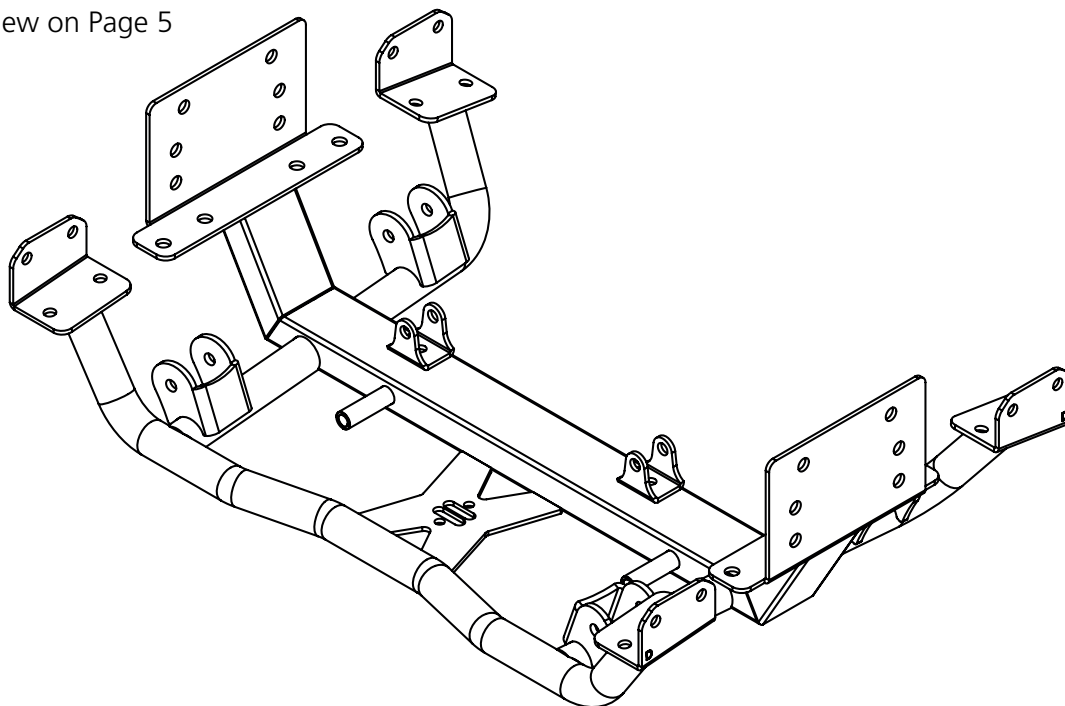

CRADLE COMPONENTS

Exploded View on Page 5

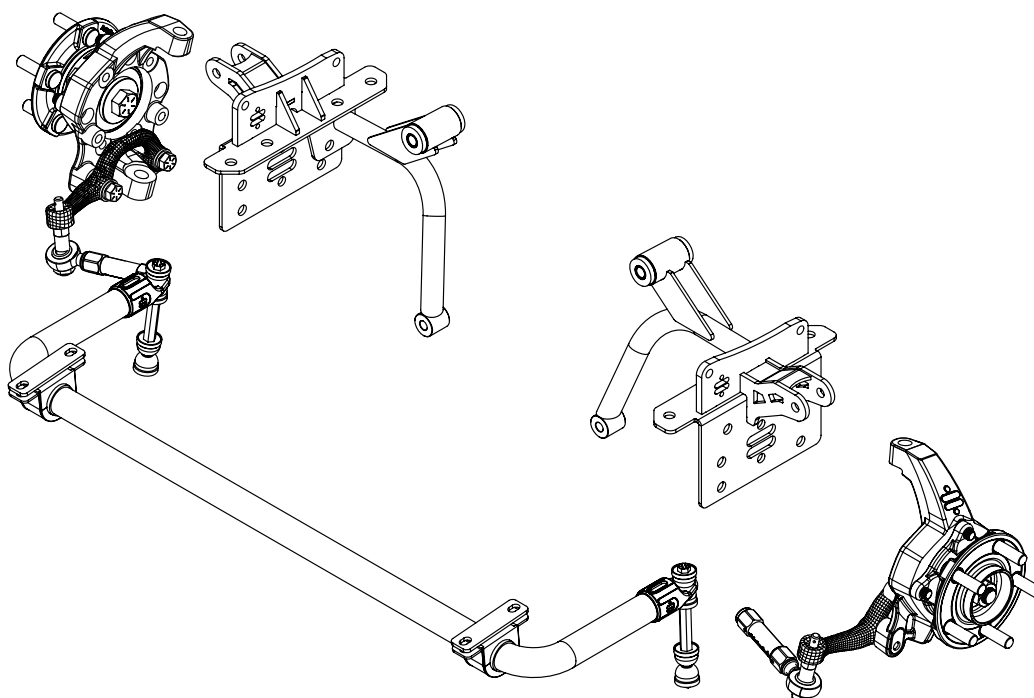



Major Components AssembledIn the box

DRIVER LOWER CONTROL ARM ASSEMBLY

Exploded View on Page 6

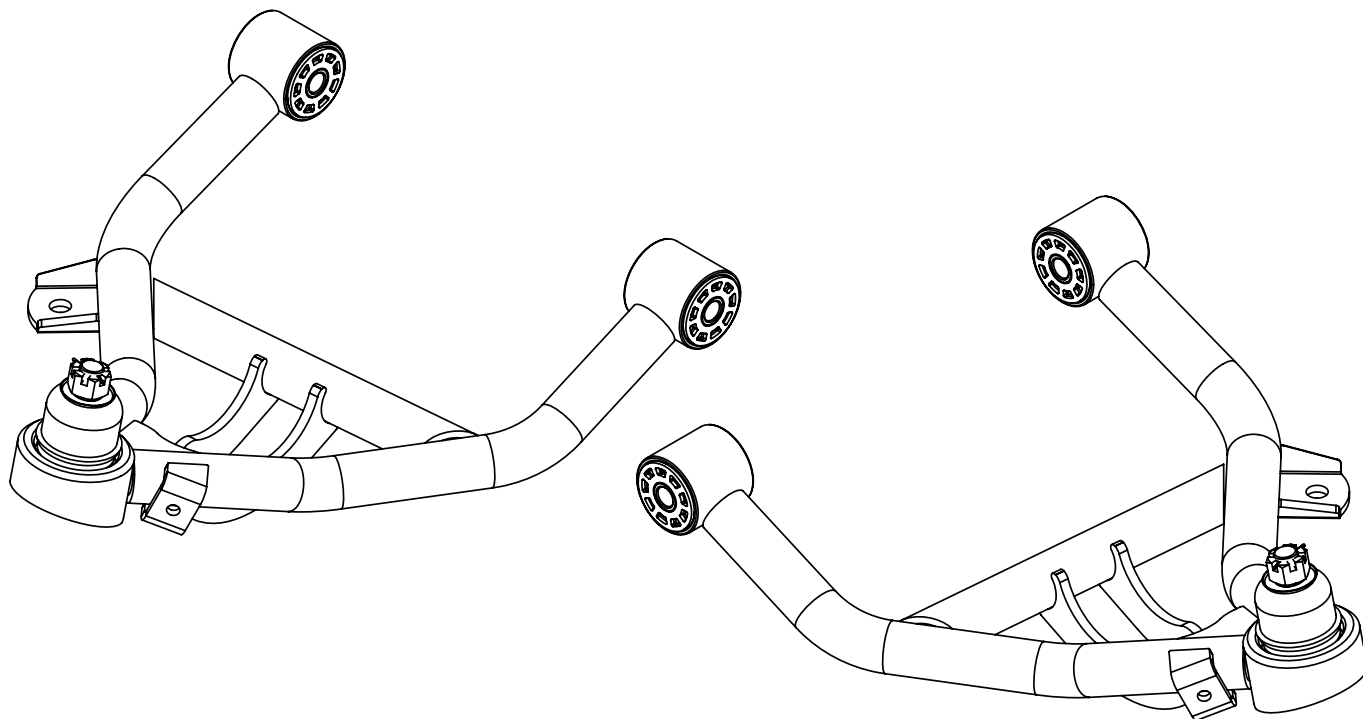

DRIVER UPPER CONTROL ARM ASSEMBLY

Exploded View on Page 6

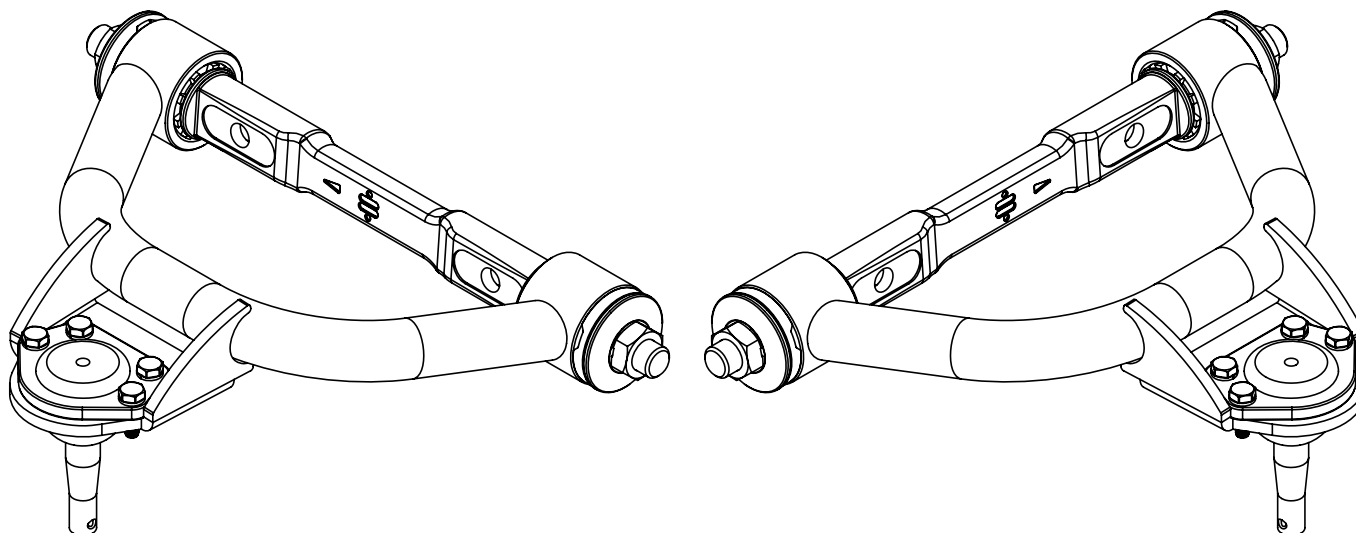



This system includes 2015-2023 S550 Mustang rear hubs. If replacing these in the future, the 3/4" retaining bolt and t-washers must be installed into the new hub. This hardware needs to be torqued to 200 ft-lbs. **Failure to do will result in immediate bearing failure.**

Item #	Part Number	Description	QTY
2	70013663	Hub Bearing (Moog 512517)	1
2a	90003508	Top T-Washer	1
2b	90003509	Bottom T-Washer	1
2c	99751006	3/4"-16 x 3 1/2" Bolt	1
2d	99752005	3/4"-16 Lock Nut	1

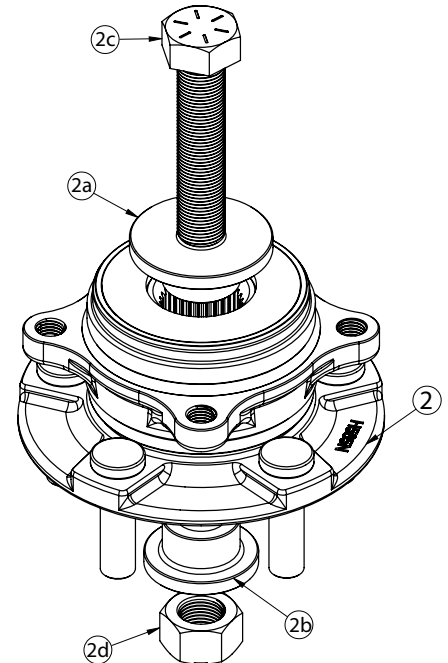

If replacing the hubs in the future, the center bolt and t-washers will need to be installed in the new hub. Torque the 3/4" bolt and nut to 200 ft-lbs.

Upper Control Arm ComponentsIn the box

Item #	Part Number	Description	QTY
1	11009300	Hub Bearing Spindle Kit	1
1a	70015751	Hub Spindle	2
1b	90003535	Steering Arm Threaded Slug	4
1c	99121018	M12-1.5 x 40mm Socket Head Cap Screw	8
2	12129501	Bearing Hub Assembly	
3	90003386	Cradle Assembly	1
4	90003387	Upper Control Arm Mount - Driver	1
5	90003388	Upper Control Arm Mount - Passenger	1
6	90003395	Motor Mount - Driver	1
7	90003396	Motor Mount - Passenger	1
8	70015348	Poly Bushing (Pack of 4)	2
9	90002672	Inner Sleeve - 9/16" ID x 3.0" long	2
10	90003000	Steering Arm Kit - Driver and Passenger	1



Upper Control Arm ComponentsIn the box

Item #	Part Number	Description	QTY
11	90003399	Tie Rod Stud	2
12	90001582	Heim End - 5/8" -18 LH x 5/8" Bolt	2
13	90002676	1/8" Tie Rod Spacer	2
14	90003400	Tie Rod Adjuster - 5/8" -18 LH & 9/16" -18 x 4 1/2" Long	2
15	90003397	Sway Bar	1
16	90001346	Sway Bar Bushing Mount	2
17	70015016	1 1/2" ID Lined Sway Bar Bushing	2
18	90003398	Sway Bar Mount Spacer	2
19	90002934	Sway Bar End Link Kit	2
20	90003391	Driver Lower Control Arm (Shown)	1
20	90003392	Passenger Lower Control Arm	1
21	90000549	Inner Bushing Sleeve	4
22	70010827	Delrin Control Arm Bushing, 1.75" Shoulder	8
23	90000898	Lower Ball Joint Assembly	2
24	90003393	Bump Stop Mount-Driver	1
25	90003394	Bump Stop Mount-Passenger	1
26	70013322	Bump Stop	2
27	90000472	Bump Stop Spacer	2
28	90003389	Driver Upper Control Arm (Shown)	1
28	90003390	Passenger Upper Control Arm	1
29	90003375	Upper Control Arm Cross Shaft	2
30	70010759	Delrin Control Arm Bushing, 2.0" Shoulder	4
31	70010826	Delrin Control Arm Bushing, No Shoulder	2
32	90002737	Aluminum T-Washer	4
33	70010882	Caster Slug	4
34	90000894	Upper Ball Joint Assembly	2
35	90003934	Washer; 1.70 OD	2
36	90003933	Washer; 1.45 OD	2
37	99622005	5/8" -18 Thin Top Lock Nut	4
38	99501043	1/2" -13 x 2" Hex Bolt - Steering Arm	2
39	99501026	1/2" -13 x 2 1/4" Hex Bolt - Steering Arm	2
40	99503014	1/2" SAE Flat Washer	4



Cradle and Steering ComponentsIn the box

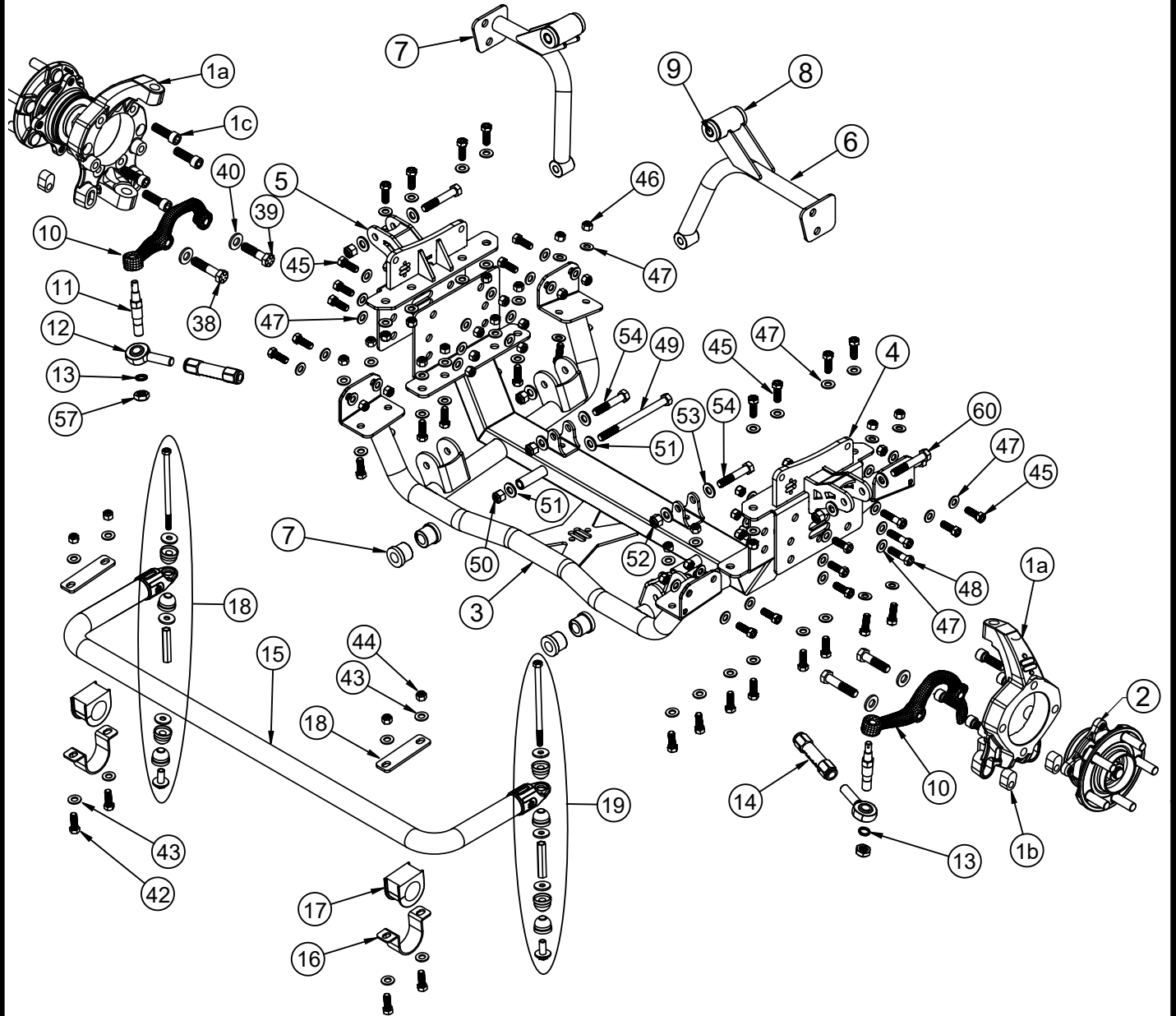



Control Arm ComponentsIn the box

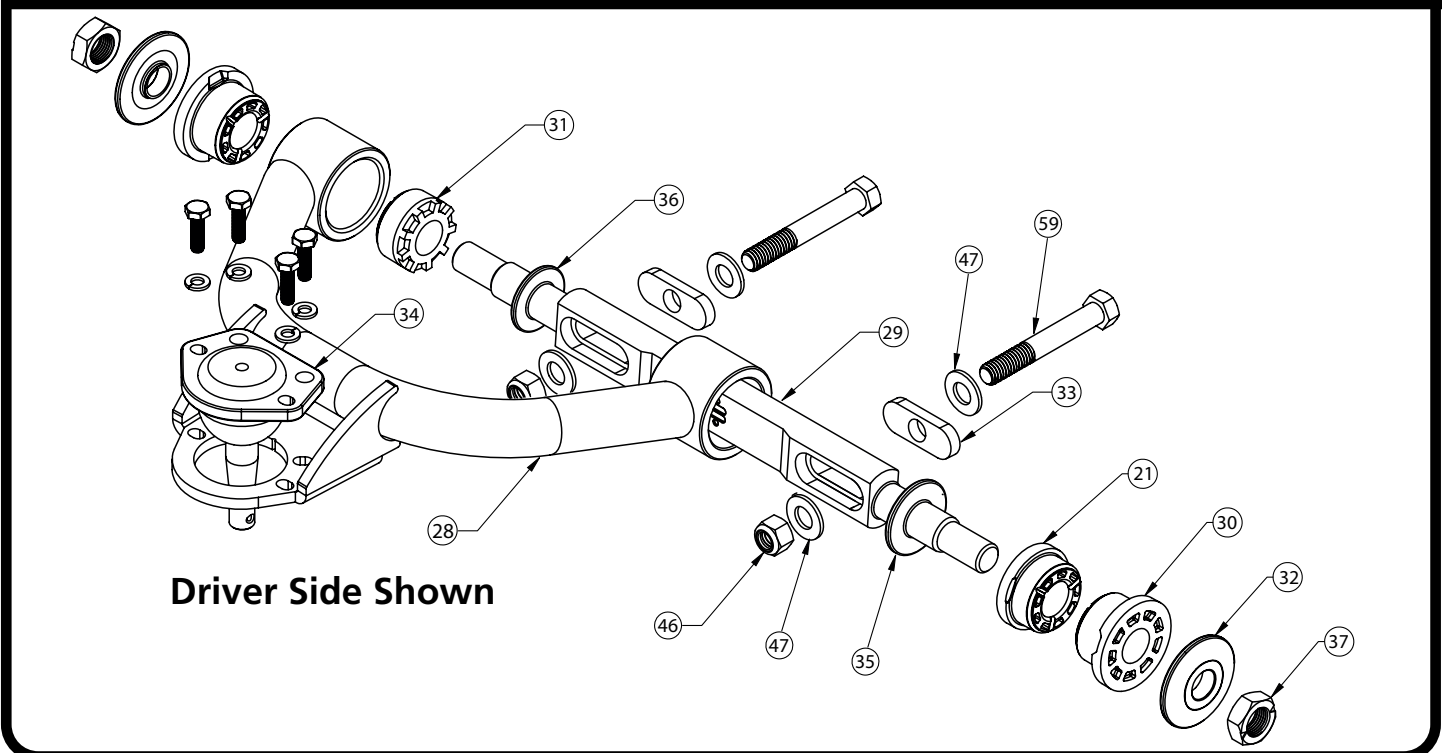
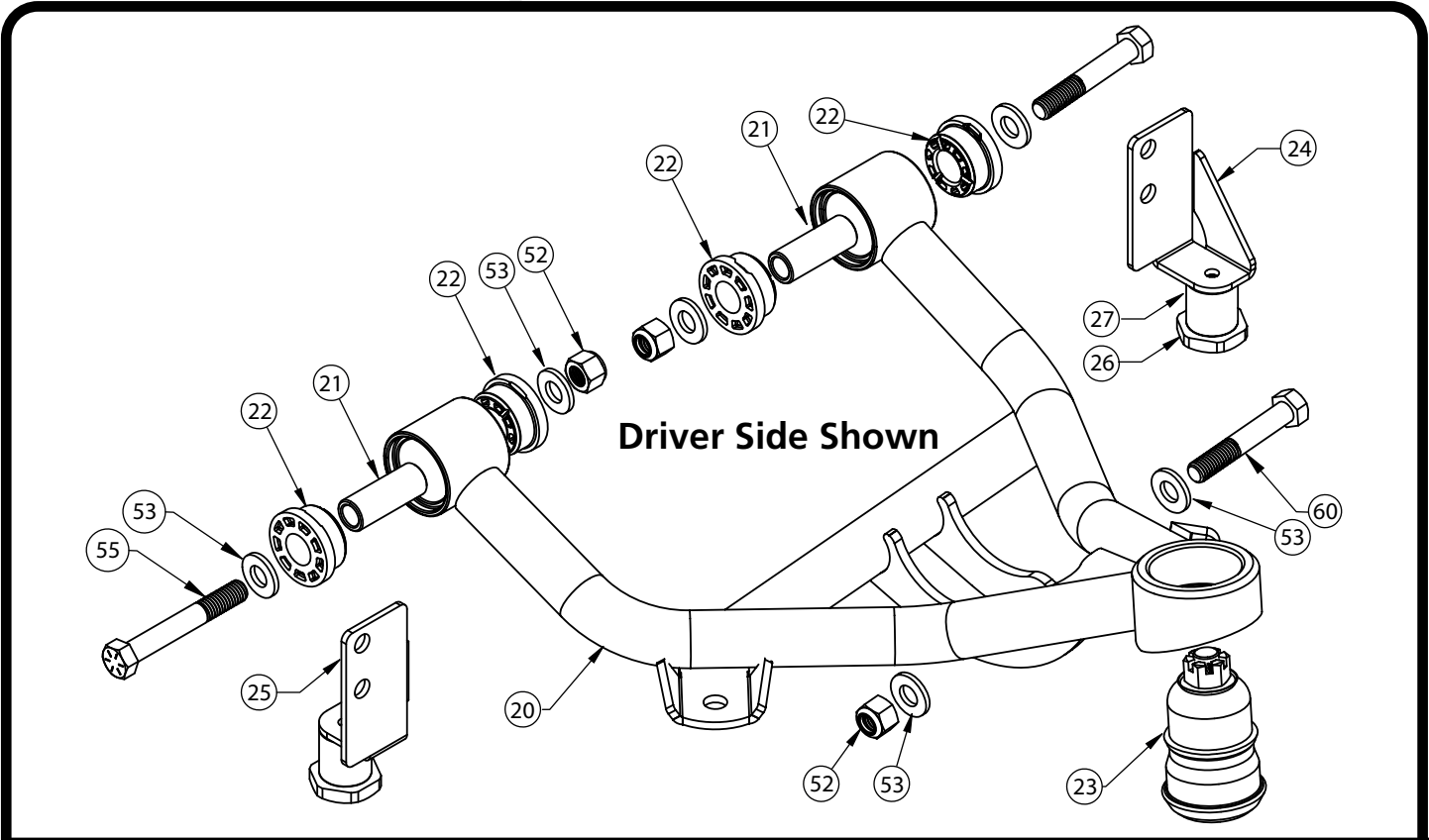



Hardware Kit ListsIn the boxes

THIS KIT INCLUDES (5) HARDWARE KITS. THE KITS ARE BROKEN DOWN ON THIS PAGE. THE HARDWARE KITS ARE LABELED AND BAGGED ACCORDING TO THE LOCATION THEY ARE USED. THESE LISTS, ALONG WITH THE DIAGRAMS ON THE PREVIOUS PAGES, WILL HELP GUIDE YOU WITH THE KIT INSTALLATION.

THE STEERING KIT CONTAINS KIT #S:
99010192
99010201
99010206

THE LOWER CONTROL ARM KIT CONTAINS KIT #:
99010204

THE LOWER CONTROL ARM KIT CONTAINS KIT #:
99010205

Kit #99010204

Item #	Part Number	Description	QTY
LOWER CONTROL ARM TO CRADLE			
52	99502009	1/2"-13 Nylok Nut	4
53	99503014	1/2" SAE Flat Washer	8
55	99501005	1/2"-13 x 3 1/2" Hex Bolt	4
BUMP STOP TO BRACKET			
56	99371001	3/8"-16 x 3/4" Hex Bolt	2
57	99373003	3/8" SAE Flat Washer	2
58	99373005	3/8" Split Lock Washer	2

Kit #99010205

Item #	Part Number	Description	QTY
UPPER CONTROL ARM TO MOUNT			
59	99431021	7/16"-14 x 3" Hex Bolt	4
46	99432010	7/16"-14 Nylok Nut	4
47	99433005	7/16" Flat Washer	8
SHOCK TO SHOCK MOUNTS			
60	99501004	1/2"-13 x 3" Hex Bolt	4
52	99502009	1/2"-13 Nylok Nut	4
53	99503014	1/2" SAE Flat Washer	8

Kit #99010192

Item #	Part Number	Description	QTY
SWAY BAR TO FRAME			
42	99371005	3/8"-16 x 1 1/4" Hex Bolt	4
43	99373002	3/8" Flat Washer	8
44	99372001	3/8"-16 Nylok Nut	4

Kit #99010201

Item #	Part Number	Description	QTY
CRADLE/UPPER ARM MOUNT TO FRAME			
45	99431021	7/16"-14 x 1 1/4" Hex Bolt	38
46	99432010	7/16"-14 Nylok Nut	44
47	99433005	7/16" Flat Washer	88
48	99431023	7/16"-14 x 1 3/4" Hex Bolt	6
RACK TO CRADLE			
49	99121017	M12-1.75 x 170mm Bolt	2
50	99122009	M12-1.75 Nylok Nut	2
51	99123002	M12 Flat Washer	4
MOTOR MOUNT TO CRADLE			
52	99502009	1/2"-13 Nylok Nut	2
53	99503014	1/2" SAE Flat Washer	4
54	99501064	1/2"-13 x 2 3/4" Hex Bolt	2

Kit #99010206

Item #	Part Number	Description	QTY
TIE ROD STUD			
61	99622006	5/8"-18 THIN Lock Nut	2
Not Shown	99432005	7/16" Castle Nut	2
Not Shown	99952002	3/32" Cotter Pin	2
TIE ROD ADJUSTER			
Not Shown	99562002	9/16"-18 Jam Nut	2
Not Shown	99800003	5/8"-18 LH Jam Nut	2



Brake Bracket ComponentsIn the box

Item #	Part #	Description	QTY
62	90003539	Caliper Bracket - Driver	1
	90003540	Caliper Bracket - Passenger (Not Shown)	1

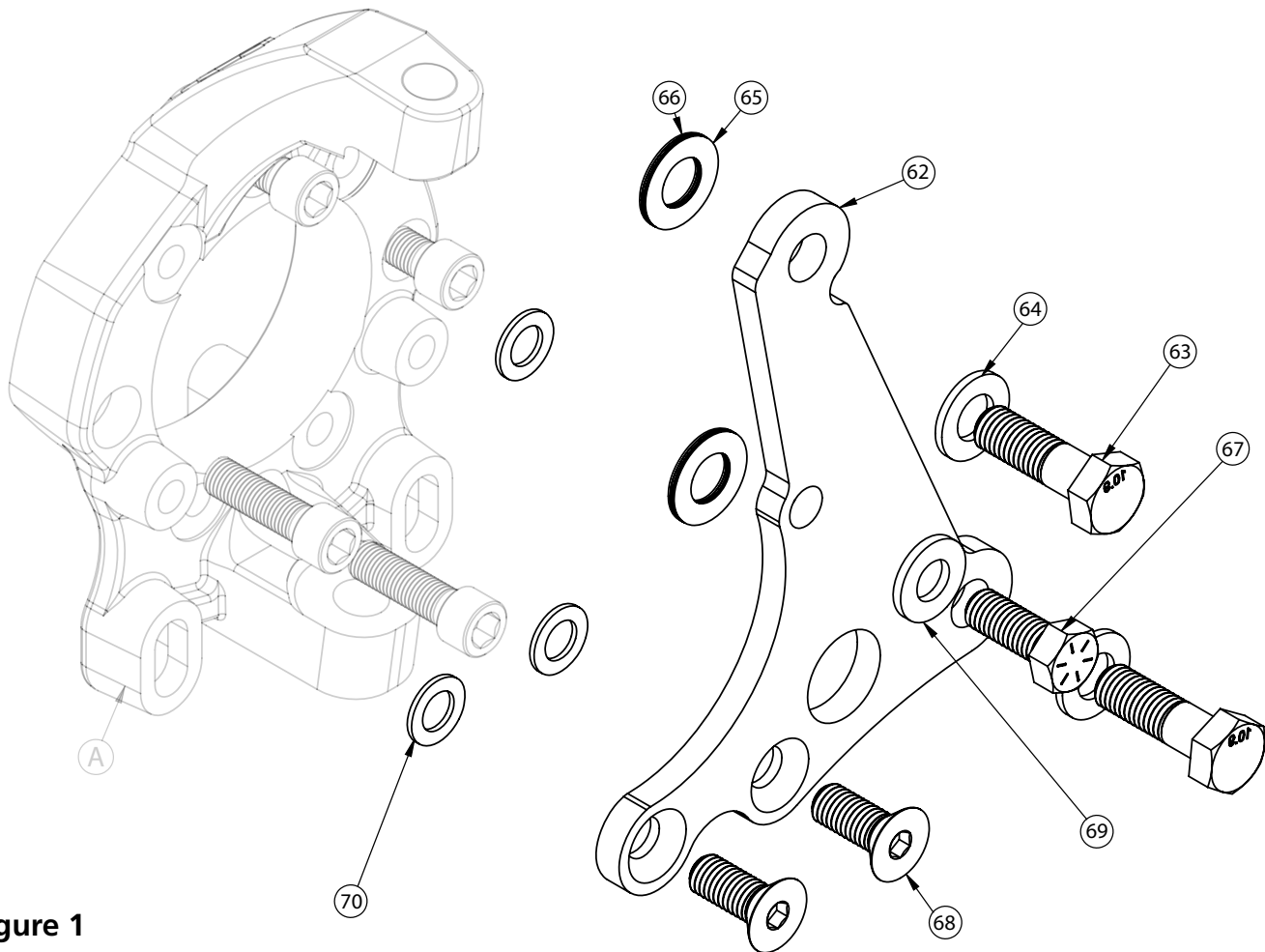

Figure 1

Hardware ListIn the box (Kit # 99010227)

Item #	Part Number	Description	QTY	Item #	Part Number	Description	QTY
BRACKET TO CALIPER				BRACKET TO SPINDLE			
63	99121005	M12-1.75 X 30mm Hex Bolt	4	67	99501062	1/2"-13 x 1 1/4" Hex Bolt	2
64	99123002	M12 Flat Washer	4	68	99501075	1/2"-13 x 1 1/4" FHSCS	4
SHIM PACK				69	99503014	1/2" SAE Flat Washer	2
65	99503018	Shim .016" thick, 1/2" ID	8	70	99503017	Shim .063" thick, 1/2" ID	6
66	99503019	Shim .032" thick, 1/2" ID	8				



Important Notes

This kit requires removal of the engine. It can not be installed with the engine in the truck.

If using the factory steering column, you will need U-Joint Kit # 12319505. If using an aftermarket column, the required components will differ depending on the column manufacturer.

This kit requires a Ridetech Motor Mount Kit. We have different kits for different engines.

Small Block Ford	12319501
Ford Modular Motor 4.6/5.4/ Coyote	12319503
Ford FE	12319504
GM Small Block/ Big Block/ LS	12319502

This suspension kit is designed to use a 1979-1993 Ford Mustang Rack and Pinion.

If your truck has drum brakes, a disc brake master cylinder will be required.

The OEM front crossmember needs to be cut out of the truck.

The radius arm crossmember will remain in the truck.

The Hub Bearing used in this kit is a 2015-2022 S550 Mustang hub bearing. It has a 5 on 4 1/2" bolt pattern for the wheel mounting. The studs of the hub bearing are 14mm.

The Caliper Brackets included in this kit are designed to use 2015-2022 S550 Front rotors and caliper/ caliper brackets. Any brake kit designed for the 2015-2022 Mustang should fit this kit.

Wheel Fitment: If you are planning on running more than 4 1/2" back spacing, this kit will require at least an 18" diameter wheel.

Disassembly

1. Remove the engine from the truck. The transmission can be left in the truck, but will need to be supported.
2. Remove the entire front suspension and steering from the truck. Refer to the factory service manual for disassembly procedure.
3. Remove the OEM steering box from the truck.



Disassembly



4. Remove the OEM engine mount stands.



5. The bottom rear of the OEM crossmember may have a bolt instead of a rivet. If so, remove the bolt.



6. The OEM upper coil spring and I-beam mounts need to be removed from the frame rail. This can be done by either drilling the rivets out or removing the rivet heads and driving them out. We remove the rivet heads by cutting a " + " in the head with a die grinder then we cut the head off with a hammer and chisel or with an air chisel. Once the head is removed, the rivet can be driven out with a hammer and punch.



Disassembly



7. Remove the side and bottom rivets from the frame mounts.



8. Remove the coil spring mount from the frame. Do this for both sides.



9. The OEM i-beam cross member will need to be cut out of the truck. It needs to be cut out even with the top of the frame rail. We also cut the cross member in the center for easier removal. We used a saw-z-all to cut the cross member out of the truck.



Disassembly



10. **Image 10** shows the cross member cut on the drivers side.

+



11. **Image 11** illustrates the cross member removed from the truck frame.



12. Cut the OEM steering box mount out of the frame by cutting it along the top and bottom frame rail.



Disassembly



13. Remove the steering box inner spacer. This mount can be removed by straightening the (2) tabs that stick through the frame.



14. The vertical sections that are inside the frame rail need to be removed. The frame surface needs to be flat. We cut these out using a die grinder and cut off wheel.



15. We grind the top of the cross member back to the frame rail.



Disassembly



16. The inside of the frame rails need to be ground smooth.



17. Your truck may have a brake line bracket right behind the coil spring mount that will need to be removed from the frame rail. This mount usually attaches with a rivet and bolt. Remove the bolt and rivet to remove the mount.



18. There is a pin that sticks down from the bottom of each frame rail that needs to be removed. These pins are in front of the OEM cross member. These need to be cut off even with the frame rail.



Disassembly



19. Smooth the outside of the frame rail. If you are planning to paint the frame rail, now is a good time to do it.

73-79 F100 ONLY!!! Cradle Installation



20. The 73-79 F100 trucks passenger frame rail has a section of the frame bent downward. This bent down area is in the location of the rear crossmember mount. This area needs to be flattened for cradle installation. The cradle can be lifted in position to mark the area that needs flattened.



21. We used an adjustable wrench to bend the flange flat. Tighten the adjustable wrench tight to the rail and use the wrench to bend it upward. You will need to work up and down the frame rail bending it up to get the frame rail flat.



Cradle Installation

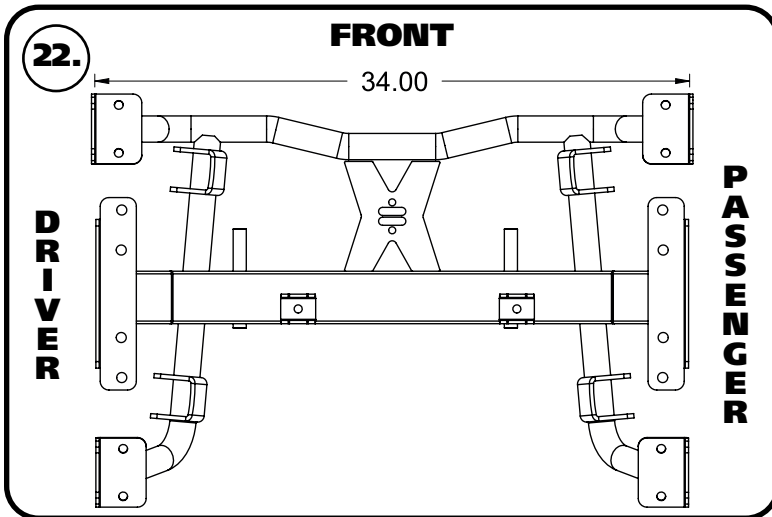

22. *Diagram 22* shows a top view of the cradle to illustrate which way it goes in the truck. The round tube of the cradle is to the front of the truck.



23. Raise the cradle up into position. The (6) holes in the large side plates will align with the (6) OEM rivet holes.



24. Position the cradle so that the (6) holes of the side plate align with the rivet holes in the frame.



Cradle Installation

25.

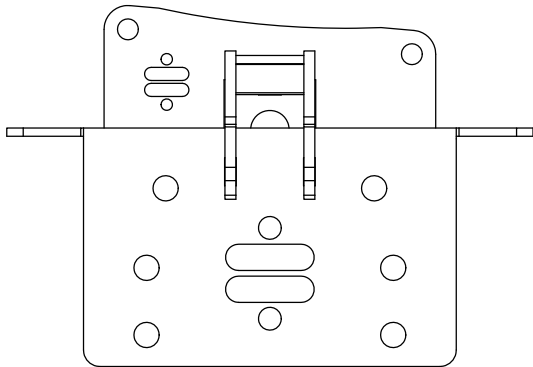

**DRIVER
SIDE**

25. Diagram 25 illustrates the Driver side upper control arm mount. This mount is mounted on the outside of the frame, over top the cradle. The (6) holes of the upper control arm mount, align with the cradle and frame holes.

26.



26. Install a 7/16" flat washer on each of (3) 7/16"-14 x 1/4" hex bolts. Insert a bolt in the front (3) bolt holes. Install a 7/16" flat washer and 7/16"-14 nylok nut on the threads of the bolt. This will help keep everything aligned. Do this for both sides.

27.



27. The kit contains a Driver and Passenger side engine mount. The frame side of the engine mount will align with the top (2) holes of the rear set of holes. The bushing side of the engine mount gets inserted into the mounts on the cradle tube. Position the engine mounts in place. Install a 1/2" flat washer on each of (2) 1/2"-13 x 2 3/4" hex bolts. Insert the bolt through the cradle mounts and bushings. Install a 1/2" flat washer and 1/2"-13 nylok nut on the threads of each bolt. Leave the hardware loose until later.



Cradle Installation



28. Install a 7/16" flat washer on a 7/16"-14 x 1 3/4" hex bolt. Insert the bolt in the top hole of the rear (3) bolt holes. This bolt will go through the upper control arm mount, cradle plate, & engine mount. Install a 7/16" flat washer and 7/16"-14 nylok nut on the threads of the bolt. **DO NOT INSTALL A BOLT IN THE LOWER HOLE OF THE ENGINE MOUNT HOLE AT THIS TIME.**



29. The bump stop mount attaches to the (2) lower holes of the rear (3) holes. The kit includes a Driver & Passenger bump stop mount. The gusset of the mount goes to the rear of the truck. Install a 7/16" flat washer on (2) 7/16"-14 x 1 3/4" hex bolts. Align the bump stop mount with the bottom (2) holes of the rear (3) holes. Insert the bolts in the mounting holes. The top bolt will go through the bump stop mount, upper control arm mount, cradle plate, & engine mount. The bottom bolt doesn't go through the engine mount. Install a 7/16" flat washer and 7/16"-14 nylok nut on the threads of the bolts. Do this for both sides. Thread the bump stop into the aluminum spacer. Attached the bump stop/spacer to the mount using a 3/8"-16 x 3/4" bolt, lock washer, and flat washer.



30. Install a 7/16" flat washer on each of (2) 7/16"-14 x 1 3/4" hex bolts. Insert the bolt/washers in the remaining bottom (2) bolts holes of the front (3) bolt holes. Install a 7/16" flat washer and 7/16"-14 nylok nut on the threads of the bolts. Do this for both sides. Snug the hardware, but do not torque the hardware at this time.



Cradle Installation



31. There are (8) mounting holes in the bottom mounts of each side of the cradle. All but (2) of these will need to be drilled with a 7/16" drill bit. (2) of the holes will align with factory holes.



32. Install a 7/16" flat washer on each of (8) 7/16"-14 x 1/4" hex bolts. Insert a bolt/washer in each bottom (8) holes. Install a 7/16" flat washer and 7/16"-14 nylok nut on the threads of the bolts. Again, snug the hardware down, but do not torque the hardware at this time. Do this for both sides.



33. Drill the (4) holes for the front & rear side frame mounts using a 7/16" drill bit.



Cradle Installation



34. Install a 7/16" flat washer on each of (4) 7/16"-14 x 1/4" hex bolts. Insert a bolt/washer in each of the (4) holes. Install a 7/16" flat washer and 7/16"-14 nylok nut on the threads of the bolts. Again, snug the hardware down, but do not torque the hardware at this time. Do this for both sides.



35. The top flange of the upper control arm mount has (4) mounting holes. (2) of these mounting holes will align with OEM holes. (2) need to be drilled with a 7/16" drill bit.



36. Install a 7/16" flat washer on each of (4) 7/16"-14 x 1/4" hex bolts. Insert a bolt/washer in each top (4) holes. Install a 7/16" flat washer and 7/16"-14 nylok nut on the threads of the bolts. Torque all 7/16" cradle hardware to 70 ft-lbs. Torque the 1/2" engine mount hardware to 75 ft-lbs.



Lower Control Arm Installation

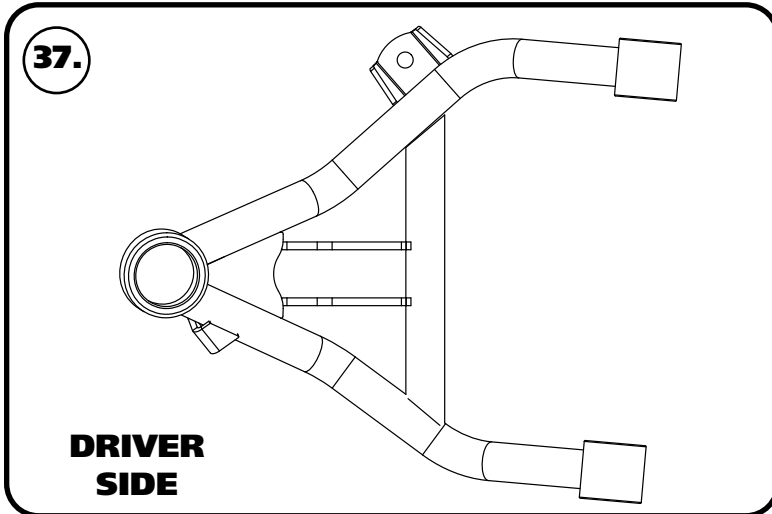

37. The lower control arms are marked "D" for Driver and "P" for Passenger. The ball joint pin points up and the sway bar mount is on the front side of the arm. **Diagram 37** shows a top view of the Driver lower control arm.



38. Insert the lower control arm in the mounts built in the lower cradle. Align the mounting holes of the lower mounts with the through hole of the bushing sleeves.



39. Install a 1/2" flat washer on each of (2) 1/2"-13 x 3 1/2" hex bolts. Insert the bolt/washer in the aligned holes with the threads to the rear of the truck. Install a 1/2" flat washer & 1/2"-13 nylok nut on the threads of the bolts. Repeat on the passenger side control arm. Torque the mounting bolts to 75 ft-lbs.



Caster Explained

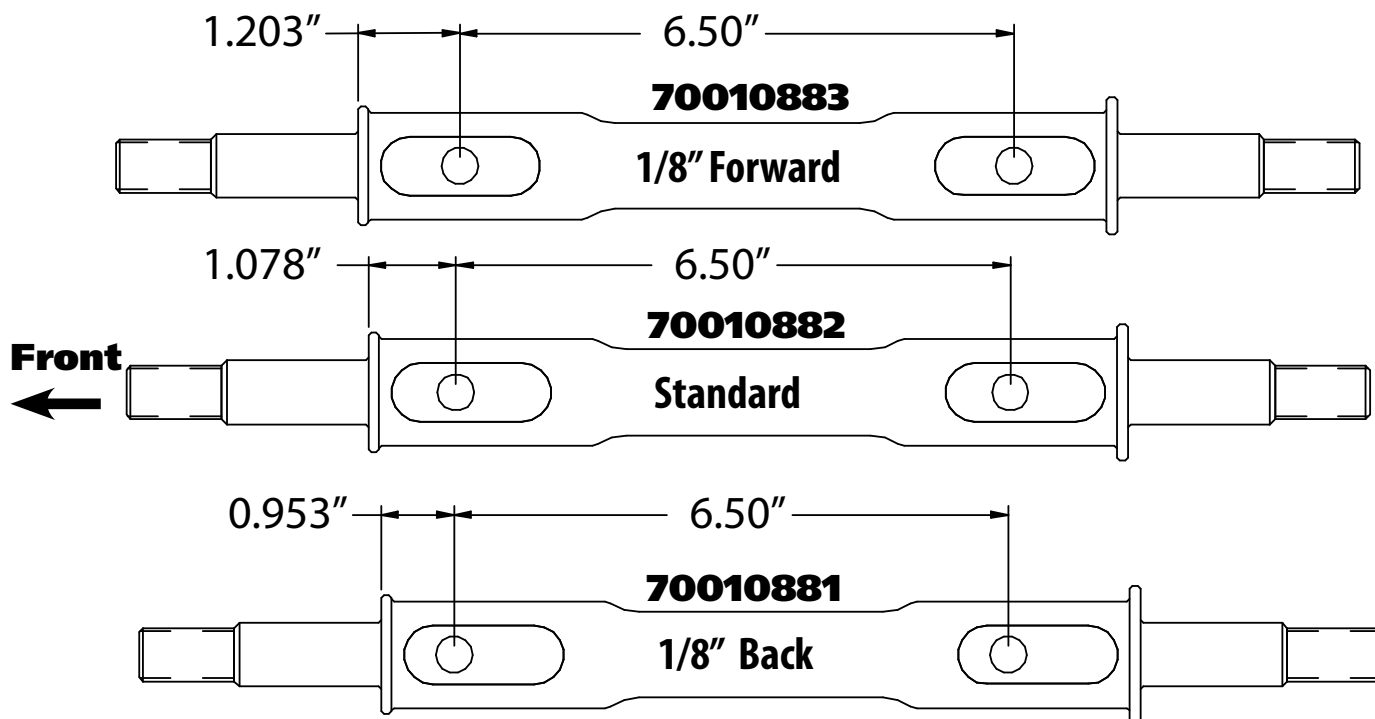

These StrongArms come equipped with a changeable caster slug setup. This allows you to add or remove caster from the front suspension, if desired. The caster slugs that come supplied in the kit are standard (70010882). The caster slugs allow you to add or remove caster without having to use a stack of shims. If more or less caster is desired, optional slugs can be purchased from Ridetech or your Ridetech dealer.

1/8" Forward = 70010883

1/8" Back = 70010881

Caster Explained:

To understand caster you need to picture an imaginary line that runs through the upper ball Joint and extends through the lower ball Joint. From the side view the imaginary line will tilt forward or backward. The tilting of this imaginary line is defined as caster.

Caster is measured in degrees by using a caster gauge. If the imaginary line described above tilts towards the back of the vehicle at the top, then you have positive caster. If the imaginary line tilts forward then you have negative caster.

Positive caster provides the directional stability in your vehicle. Too much positive caster will make the steering effort difficult. Power steering will allow you to run more positive caster. Negative caster requires less steering effort but will cause the vehicle to wander down the highway



Offset Upper Control Arm Shaft

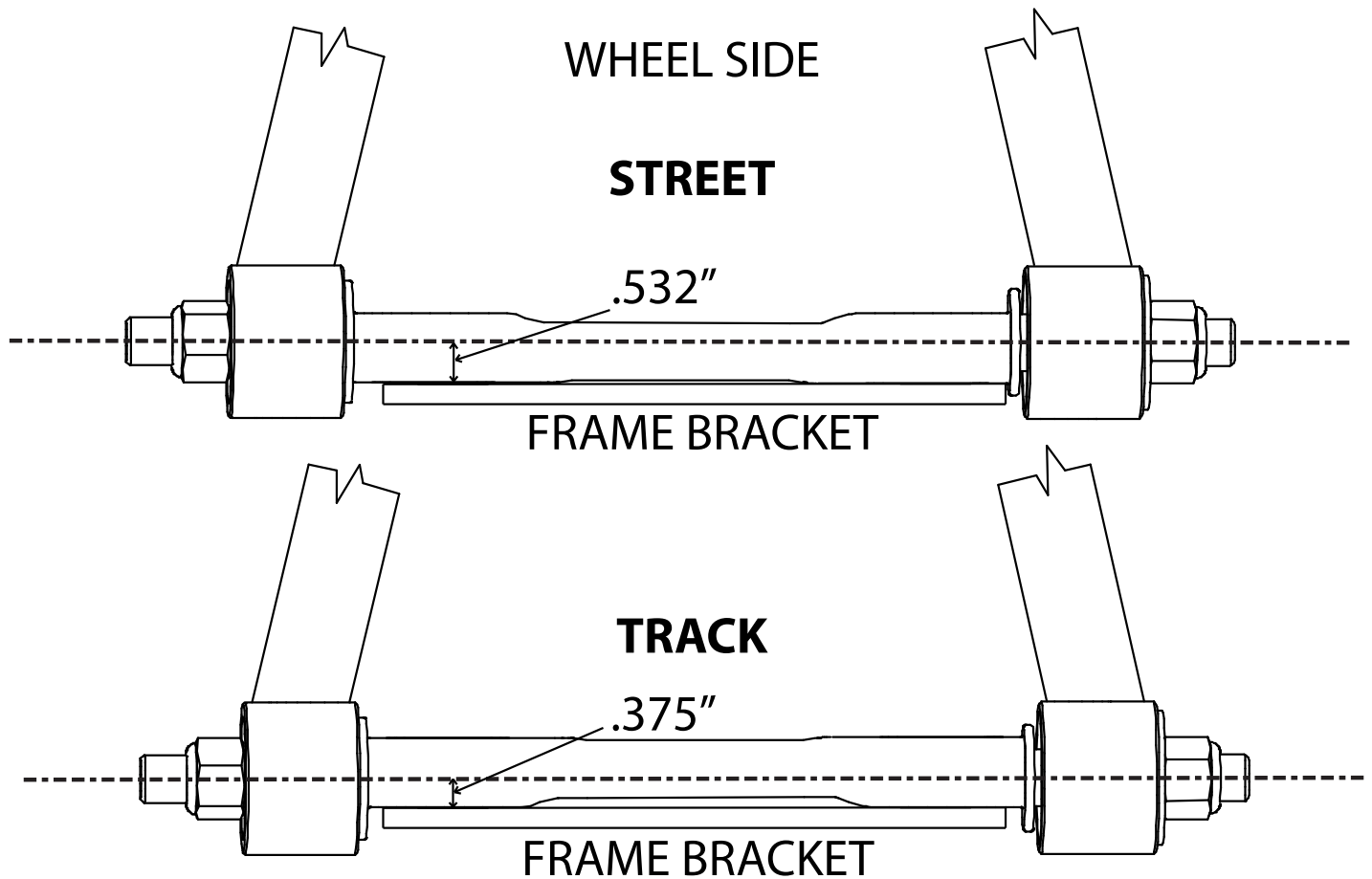

The cross shaft that is used in the upper control arms is offset. The offset combined with the caster slug option allows you to achieve the alignment setting you desire with minimal shims. To change the direction the Icon faces simply spin the cross shaft in the control arm.

If you are after a **Street Alignment** bolt the upper control arm to the frame mount with the arm offset to the outside of the truck. The Ridetech Icon will be facing the wheel.

If a more aggressive **Track or Autocross** alignment is desired, bolt the control arm to the frame bracket with the arm offset to the inside of the truck. The Ridetech Icon will be facing the frame rail.



Upper Control Arm Installation

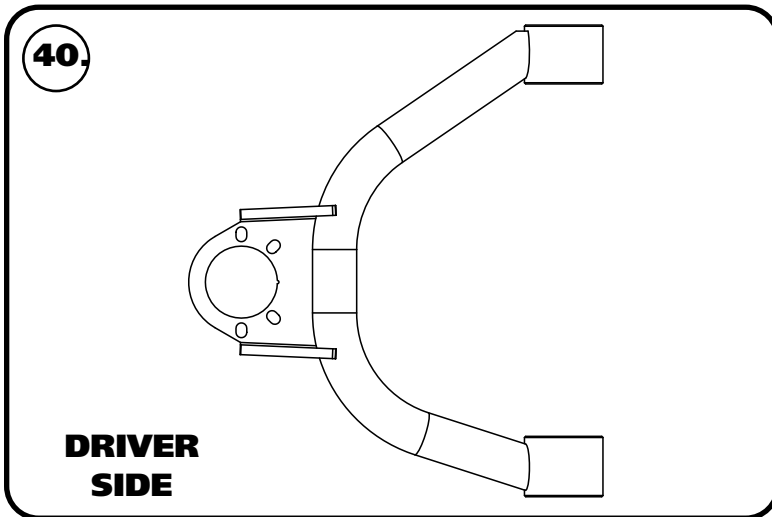

40. The upper control arms are marked "D" for Driver and "P" for Passenger. The ball joint pin points down and the ball joint is to the rear of the truck. **Diagram 40** shows a top view of the Driver upper control arm.



41. Install a 7/16" flat washer on each of (2) 7/16"-14 x 3" hex bolts. Insert a bolt/washer in each bottom (2) upper control arm mounting holes.

Note: 73-79 F100s might require you to push the inner fender out of the way to install the front upper bolt.



42. Insert the caster slug into the cross shaft using the guide on **Page 21** as a guide. **The long side of the caster slug will be to the rear of the control arm.** Slip the upper control arm onto the mounting bolts using **Page 22** as a guide for cross shaft orientation. Install a 7/16" flat washer & 7/16"-14 on the threads of each bolt. Torque the bolts to 70 ft-lbs.



Shock Installation



If installing CoilOvers, refer to the CoilOver instructions for shock assembly.

43. Insert the shock bearing t-bushings into the bearing of the eyelet. The small outside diameter of the t-bushing will insert into the shock bearing.



44. Insert the eyelet of the shock into the frame mount with the adjuster knob toward the outside of the truck. Align the mounting holes with the through hole of the shock eyelet.



45. Install a 1/2" flat washer on a 1/2"-13 x 3" hex bolt. Insert the bolt/washer into the mount/shock. Install a 1/2" flat washer & 1/2"-13 nylok nut. Torque the hardware to 75 ft-lbs.



Shock Installation



46. Insert the shock bearing t-bushings into the bearing of the shock body. The small outside diameter of the t-bushing will insert into the shock bearing.



47. Swing the lower control arm up to the shock. While swinging the control arm up, insert the shock body into the shock mount of the control arm. Align the mounting holes with the through hole of the shock body.



48. Install a 1/2" flat washer on a 1/2"-13 x 3" hex bolt. Insert the bolt/washer into the mount/shock. Install a 1/2" flat washer & 1/2"-13 nylok nut. Torque the hardware to 75 ft-lbs.



Rack Installation



49. Install one half of a poly rack bushing on the rack mounting bung of the cradle. The bushing needs to be installed on the bung with the large diameter against the cradle. Install a bushing on each mounting bung.



50. Install the rack on the bushing half. The steering shaft will be on the drivers side with the shaft pointing toward the cab.



51. Insert the 2nd half of the rack bushings into the rack. Do this for each mount.



Rack & Spindle Installation



52. Install a M12 flat washer on a M12-1.75 x 170mm hex bolt. Insert the bolt/washer into the rack mount. Install a 1M12 flat washer & M12-1.75 nylok nut. Torque the hardware to 93 ft-lbs.



53. THESE SPINDLES ARE SYMMETRICAL, THEY AREN'T SIDE SPECIFIC UNTIL THE STEERING ARM IS BOLTED ON. Install the spindle on the lower ball joint. Install the ball joint castle nut on the stud of the ball joint.

Torque Specs:

Lower Ball joint - 65 ftlbs and tighten to line up cotter pin.

Install the Cotter Pin after tightening the ball joint nut.



54. Insert the top ball joint into the spindle.

Torque Specs:

Upper Ball Joint - 50 ftlbs and tighten to line up cotter pin.

Install the Cotter Pin after tightening the ball joint nut.



Hub Bearing Installation



55. The Hub is attached to the spindle using (4) M12-1.50 x 40 SHCS. Apply RED Loctite to each of the mounting bolts. Insert them into the correct holes and Torque to 99 ftlbs.



The steering arms will **NOT** get attached to the knuckle until the brakes are attached. Refer to the caliper bracket instructions for proper assembly.

Getting Started.....

These brackets are designed around OEM 2015-2022 S500 Mustang brakes. Aftermarket brakes that are designed for these cars will also fit this spindle.

Caliper Bracket Installation

Caliper bracket and brake mounting will differ depending on the brake kit being used.

We recommend mocking up the brakes with clean dry threads before applying any loctite to the hardware. The brake bracket kits include shims for mounting the caliper brackets and calipers. The caliper brackets will use 1/2" ID .063" thick shims. This kit includes 2 different thicknesses of shims for caliper mounting, .016" and .032" thick.

The next steps will cover the installation of caliper brackets on the Ridetech spindle. **Again, mock up the brake kits with clean dry threads before using any loctite on the hardware.** We are showing the installation of the caliper bracket with the spindle off the car so it can be shown clearly.



56. Lay a .062" thick, 1/2" ID shim on each of the caliper brackets (3) mounting holes.



Caliper Bracket Installation



57 The caliper brackets are side specific. They have a D & P stamped in them. Lay the correct side caliper bracket on top of the shims, aligning the mounting holes with the mounting holes of the bracket. The counter sunk holes should facing up.



58. Insert a 1/2"-13 x 1 1/4" flat head socket cap screw in each of the lower mounting holes. Install a 1/2" flat washer on a 1/2"-13 x 1 1/4" hex bolt and insert it in the upper mounting hole. Tighten the hardware to 75 ft-lbs.



59. Install the rotor on the hub. Thread some lug nuts on the threads of the hub to hold the rotor tight on the hub.



Caliper Bracket Installation



60. The OEM caliper bracket will bolt to the spindle mount. Install a M12 flat washer on each of (2) M12-1.75 x 30mm hex bolts. Insert the bolts through the caliper bracket. Line the caliper mount up with the hardware and thread in the bolts.



61. You can use feeler gauges to measure the distance between the caliper bracket and rotor to make sure the bracket is centered as much as possible. If the caliper mount is tighter on the back side, put shims on the caliper bracket/spindle. If the caliper bracket is tighter on the front side, put shims between the caliper bracket/caliper mount. After you are happy with the fitment, the hardware will need to red loctite and torqued. Torque the 1/2" bracket to spindle hardware to 80 ft-lbs. Torque the M12 hardware to 69 ft-lbs.

Note: If you are installing aftermarket brakes, refer to the brake kit instructions for measuring the caliper placement.



62. Install the brake pads and caliper.



Steering Arm Installation

The threaded steering arm inserts can be mounted in 2 different positions. **Image 52** will help you determine the correct position for the installation on your vehicle. This position is what we determined to be the best with the Ridetech suspension.

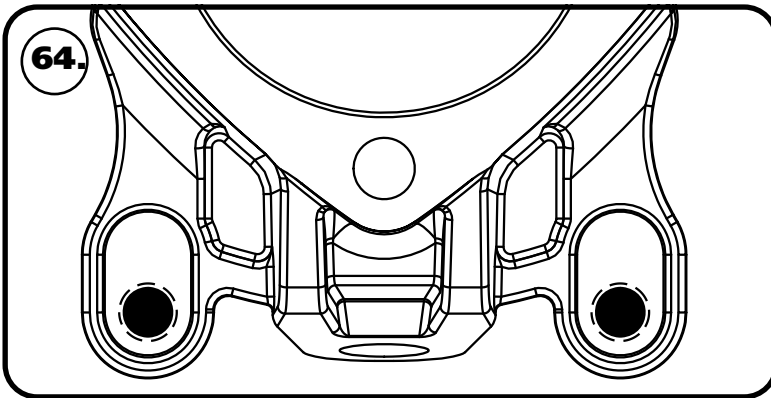

- 64.** Bottom Position:
65-79 Ford F100 Ridetech Suspension

The next 2 Images are shown with the spindle off the truck to show greater detail.



- 65.** Insert the steering arm slugs into the spindle with the threads to the bottom of the spindle,



- 66.** Hold the steering arm slugs in place. Align the mounting holes of the steering arm with the threaded holes of the slugs. Driver side steering arm is shown in **Image 66**. The tie rod end curves in to the inside of the truck. Install a 1/2" flat washer on a 1/2"-13 x 2" & 1/2"-13 x 2 1/4" hex bolts. The 1/2"-13 x 2 1/4" bolt will go in the hole closest to the tie rod end. Apply red loctite to the threads of the bolts before threading into the slugs. It is the thicker side of the mounts. Insert a bolt in each steering arm hole and thread them into the steering arm slugs. Torque to 80 ft-lbs. Repeat on other steering arm/spindle. Make sure the end of the bolt is sticking out of the slug.



Steering Linkage Installation



67. Install the stud with the hex into the steering arm with the taper going into the steering arm. Install the 7/16"-20 castle nut onto the tie rod stud. Torque the nuts to 35 ftlbs and tighten as needed to align cotter pin hole and install cotter pin.



68. The tie rod adjusters have (2) different thread sizes, 5/8"-18 LH & 9/16"-18. The left hand threaded heim will thread into the 5/8"-18 end. The rack threads into the 9/16"-18 end. Install the 5/8"-18 LH jam nut on the heim end. Install a 9/16"-18 jam nut on the threads of the rack. Thread the heim into the adjuster and thread the adjuster onto the rack.



69. Next, slip the heim end onto the tie rod stud.



Steering Linkage & Sway Bar Installation



70. Install a 1/8" thick aluminum on the bottom side of the heim end followed by a 5/8"-18 thin nylok nut on the stud. Torque the nut to 45 ft-lbs.



71. Use a tape measure to put a mark on the frame **4 1/4"** from the front edge of the cradle mount. Align the back edge of the sway bar mounting strap with the mark on the frame. Hold the mounting strap in the center of the frame and mark the center of each mounting hole. The mounting holes need to be marked on each frame rail.



72. Drill the holes using a 3/8" drill bit.



Sway Bar Installation



73. Open the sway bar bushing at the split and slip it onto the sway bar. Do this for both bushings.



74. Install the bushing mounting strap on the sway bar bushing.



75. The sway bar includes a backer plate that needs to be installed on the top side of the frame flange. Align the backer plate holes with the holes drilled in the frame.



Sway Bar Installation



76. Install a 3/8" flat washer on each of (4) 3/8"-16 x 1 1/4" hex bolts. Hold the sway bar in place and insert a bolt in the mounting hole of the mounting strap. Install a 3/8" flat washer & 3/8"-16 nylok nut on the threads of the bolt. Repeat this on remaining mounting holes. Do NOT tighten the mounting bolts at this time. They need to left loose until the sway bar linkage has been attached to the lower control arm.



77. Install the end links using **Diagram 67** as a reference. Install both end links before tightening the end link hardware.



78. Tighten the end link barrel nut until it is flush with the end of the bolt, and then tighten it 2-3 more complete rounds. Torque the frame bolts to 45 ft-lbs.



Finishing & Alignment

79. Double check the hardware to make sure everything is tight.
80. Attached the steering column to the rack and pinion.
81. Install your front brake kit.
82. Attach the correct engine mounts to the engine and reinstall the engine.
83. **FINISH PLUMBING THE BRAKE SYSTEM AND BLEED THE SYSTEM.**
84. The truck will need to be aligned.

Suggested Alignment Specs:

Camber:	Street: -.5 degrees
Caster:	Street: +3.0 to + 5.0 degrees
Toe:	Street: 1/16" to 1/8" toe in