



Part # 12320203 - 1965-1972 Ford F100 HQ Series CoilOver System

Recommended Tools

Front Components:

12312798 Front Suspension System
12313510 Front CoilOvers

Rear Components:

12327199 Rear 4Link System
12316510 Rear Coilover Instructions

Miscellaneous Components:

85000000 Spanner Wrench

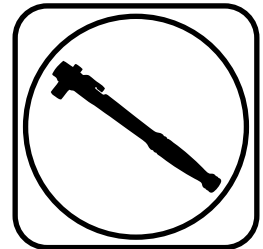

1965-1972 Ford F100 Coilover Installation Instructions

Table of contents

Pages 2-39..... Front Suspension System
Pages 40-43..... Front CoilOvers
Pages 44-59..... Rear 4-Link
Pages 60-63..... Rear CoilOvers

This kit requires removal of the engine. It can not be installed with the engine in the truck.

The OEM front crossmember needs to be cut out of the truck.

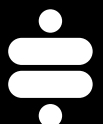



12312798

1965-1979 Ford F100 Front Suspension System w/ Hub Bearing Spindle

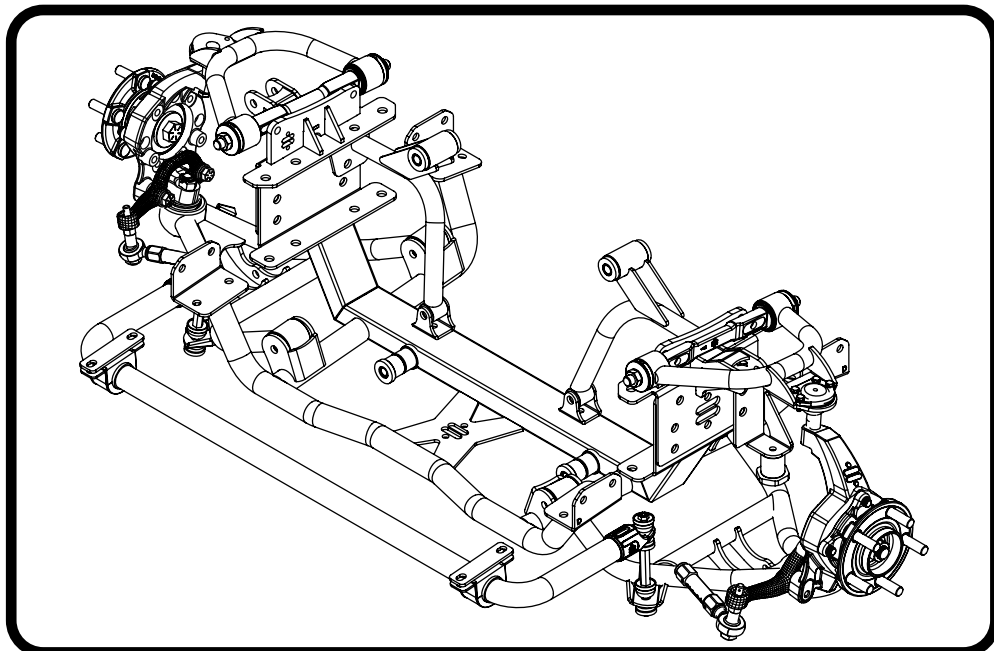

Recommended Tools

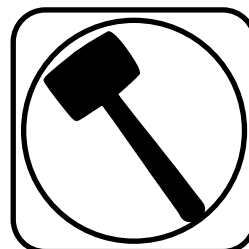
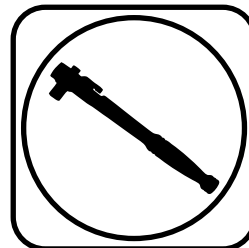

65-79 Ford F100 Front Suspension Installation Instructions

Table of contents

Page 3-4.....	Component Assemblies
Page 5-10.....	Included Components & Lists
Page 11.....	Important Notes
Page 11-17.....	Disassembly
Page 17-22.....	Cradle Installation
Page 23.....	Lower Control Arm Installation
Page 24.....	Caster Explained
Page 25.....	Offset Upper Cross Shaft
Page 26.....	Upper Control Arm Installation
Page 27-28.....	Shock Installation
Page 29-30.....	Rack Installation
Page 30.....	Spindle Installation
Page 31-33.....	Caliper Bracket Installation
Page 34.....	Steering Arm Installation
Page 35-36.....	Steering Linkage Installation
Page 36-38.....	Sway Bar Installation
Page 39.....	Finishing and Alignment

www.ridetech.com



REV3 6/16/23



Major Components AssembledIn the box

CRADLE ASSEMBLY

Exploded View on Page 5

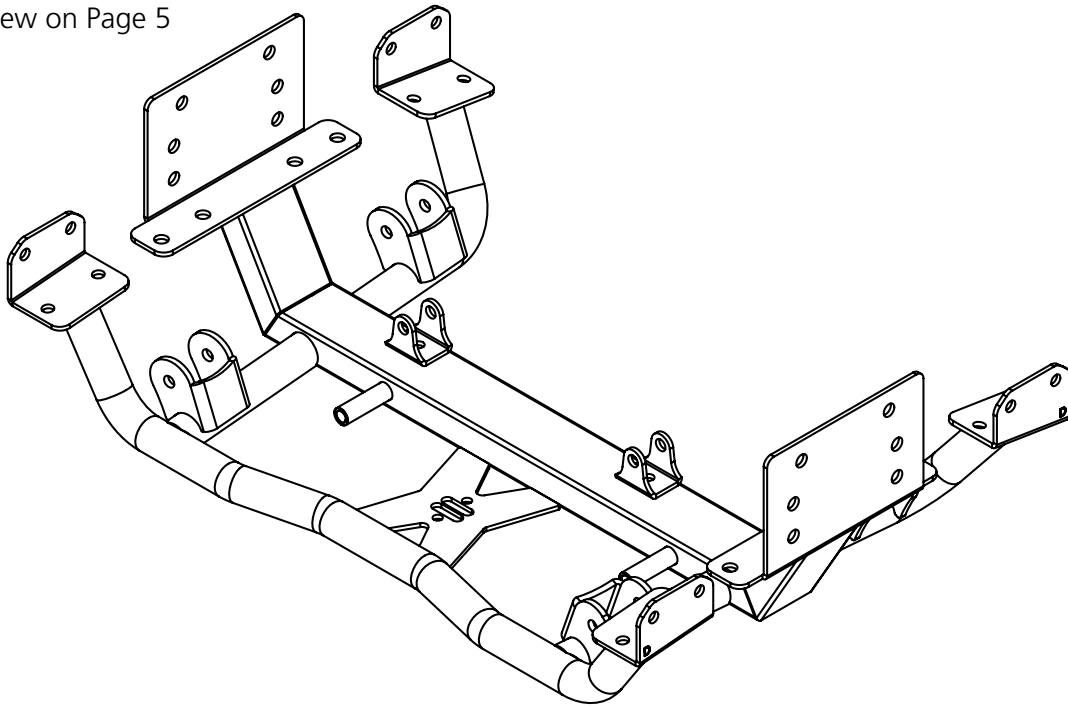

CRADLE COMPONENTS

Exploded View on Page 5

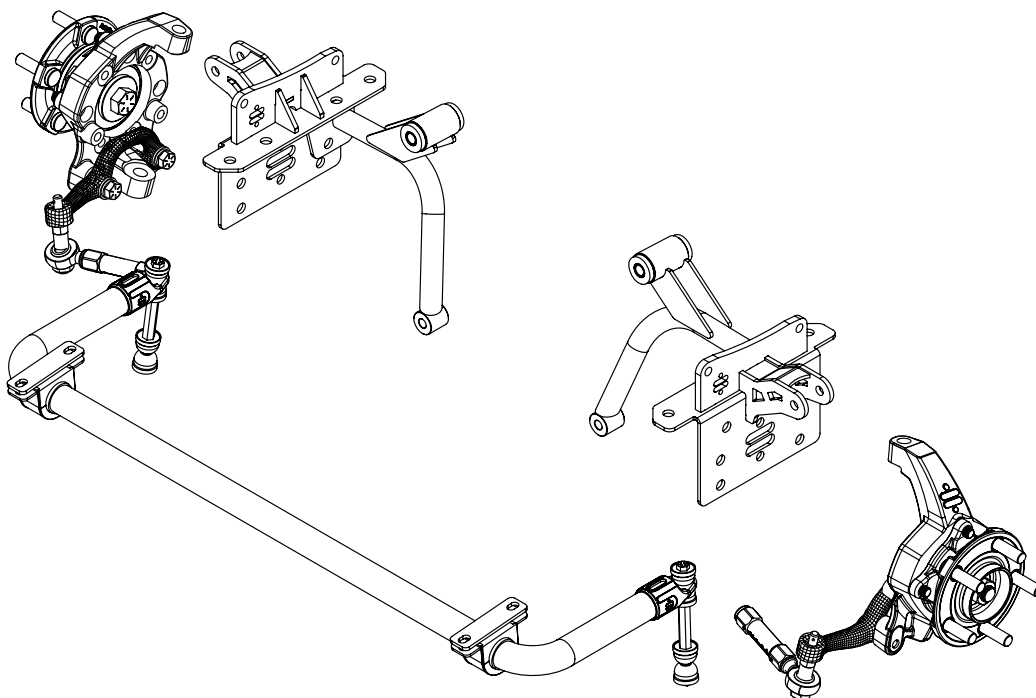



Major Components AssembledIn the box

DRIVER LOWER CONTROL ARM ASSEMBLY

Exploded View on Page 6

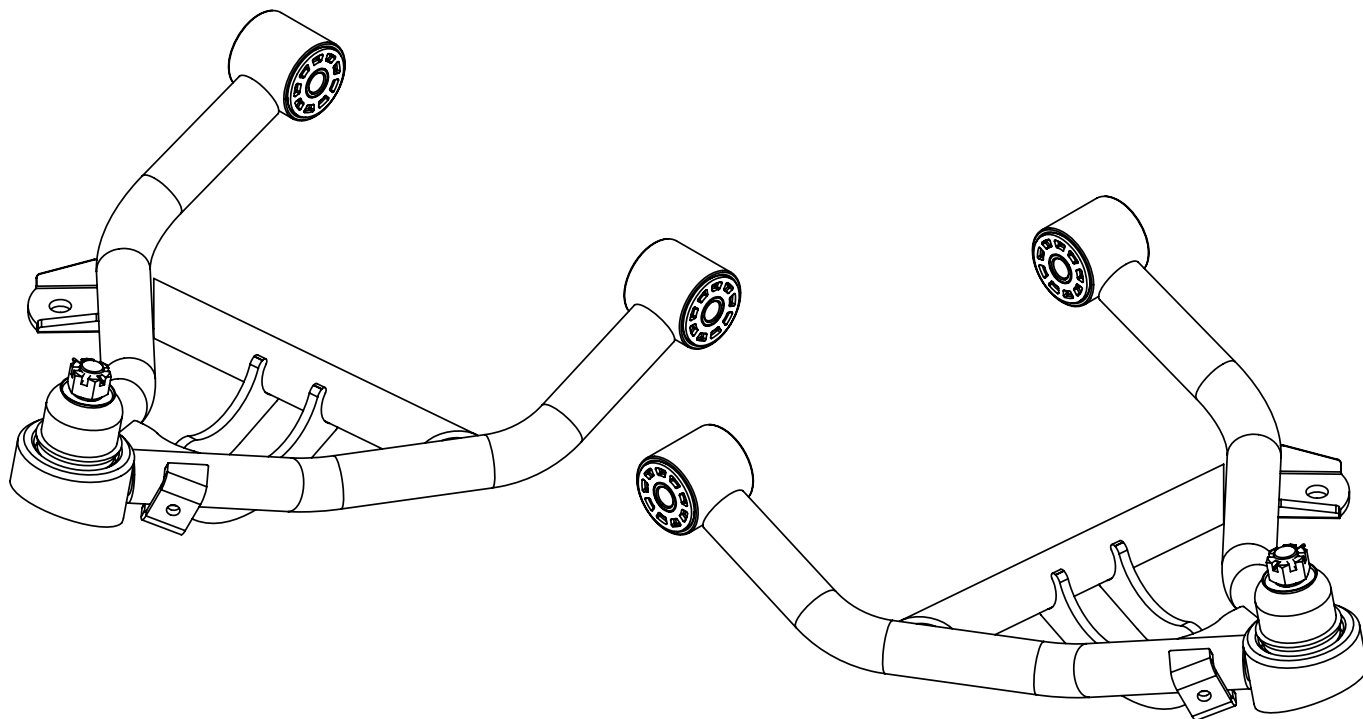

DRIVER UPPER CONTROL ARM ASSEMBLY

Exploded View on Page 6

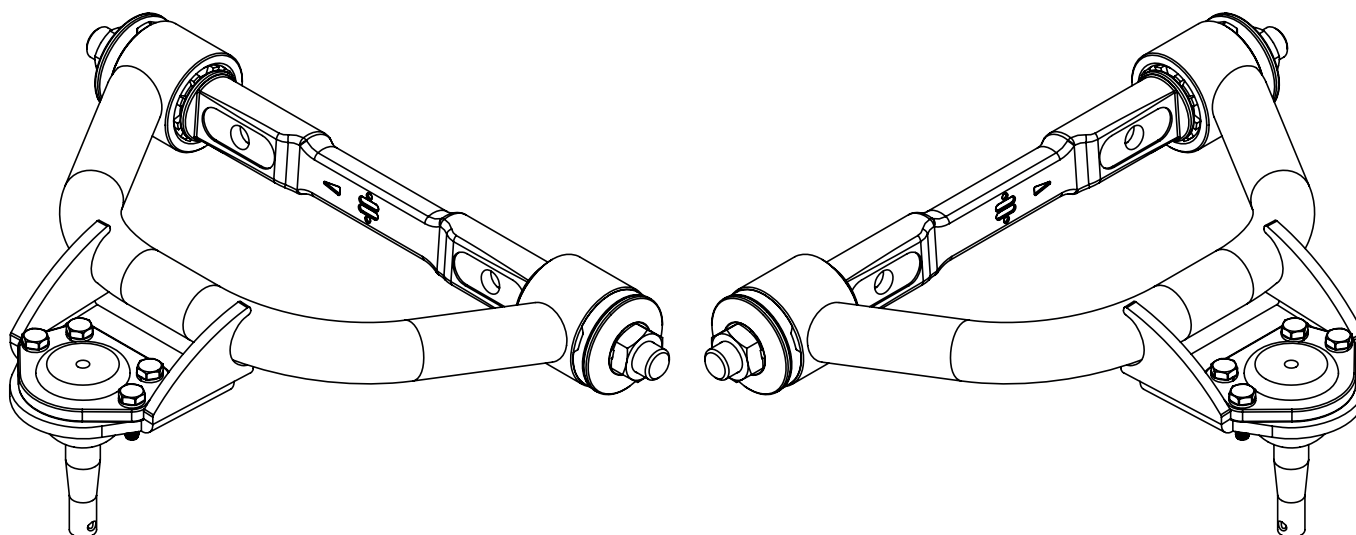



This system includes 2015-2023 S550 Mustang rear hubs. If replacing these in the future, the 3/4" retaining bolt and t-washers must be installed into the new hub. This hardware needs to be torqued to 200 ft-lbs. **Failure to do will result in immediate bearing failure.**

Item #	Part Number	Description	QTY
2	70013663	Hub Bearing (Moog 512517)	1
2a	90003508	Top T-Washer	1
2b	90003509	Bottom T-Washer	1
2c	99751006	3/4"-16 x 3 1/2" Bolt	1
2d	99752005	3/4"-16 Lock Nut	1

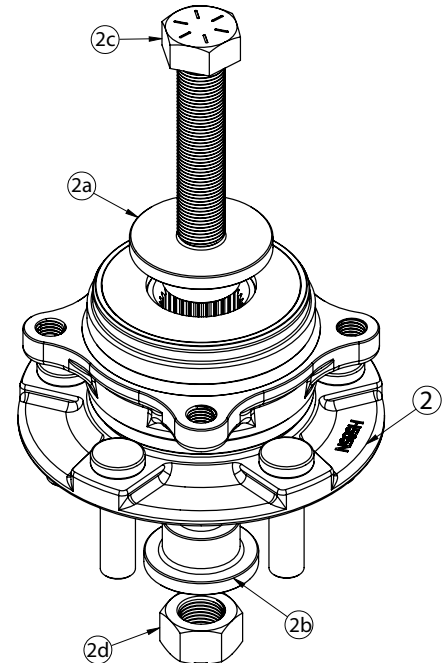

If replacing the hubs in the future, the center bolt and t-washers will need to be installed in the new hub. Torque the 3/4" bolt and nut to 200 ft-lbs.

Upper Control Arm ComponentsIn the box

Item #	Part Number	Description	QTY
1	11009300	Hub Bearing Spindle Kit	1
1a	70015751	Hub Spindle	2
1b	90003535	Steering Arm Threaded Slug	4
1c	99121018	M12-1.5 x 40mm Socket Head Cap Screw	8
2	12129501	Bearing Hub Assembly	
3	90003386	Cradle Assembly	1
4	90003387	Upper Control Arm Mount - Driver	1
5	90003388	Upper Control Arm Mount - Passenger	1
6	90003395	Motor Mount - Driver	1
7	90003396	Motor Mount - Passenger	1
8	70015348	Poly Bushing (Pack of 4)	2
9	90002672	Inner Sleeve - 9/16" ID x 3.0" long	2
10	90003000	Steering Arm Kit - Driver and Passenger	1



Upper Control Arm ComponentsIn the box

Item #	Part Number	Description	QTY
11	90003399	Tie Rod Stud	2
12	90001582	Heim End - 5/8" -18 LH x 5/8" Bolt	2
13	90002676	1/8" Tie Rod Spacer	2
14	90003400	Tie Rod Adjuster - 5/8" -18 LH & 9/16" -18 x 4 1/2" Long	2
15	90003397	Sway Bar	1
16	90001346	Sway Bar Bushing Mount	2
17	70015016	1 1/2" ID Lined Sway Bar Bushing	2
18	90003398	Sway Bar Mount Spacer	2
19	90002934	Sway Bar End Link Kit	2
20	90003391	Driver Lower Control Arm (Shown)	1
20	90003392	Passenger Lower Control Arm	1
21	90000549	Inner Bushing Sleeve	4
22	70010827	Delrin Control Arm Bushing, 1.75" Shoulder	8
23	90000898	Lower Ball Joint Assembly	2
24	90003393	Bump Stop Mount-Driver	1
25	90003394	Bump Stop Mount-Passenger	1
26	70013322	Bump Stop	2
27	90000472	Bump Stop Spacer	2
28	90003389	Driver Upper Control Arm (Shown)	1
28	90003390	Passenger Upper Control Arm	1
29	90003375	Upper Control Arm Cross Shaft	2
30	70010759	Delrin Control Arm Bushing, 2.0" Shoulder	4
31	70010826	Delrin Control Arm Bushing, No Shoulder	2
32	90002737	Aluminum T-Washer	4
33	70010882	Caster Slug	4
34	90000894	Upper Ball Joint Assembly	2
35	90003934	Washer; 1.70 OD	2
36	90003933	Washer; 1.45 OD	2
37	99622005	5/8" -18 Thin Top Lock Nut	4
38	99501043	1/2" -13 x 2" Hex Bolt - Steering Arm	2
39	99501026	1/2" -13 x 2 1/4" Hex Bolt - Steering Arm	2
40	99503014	1/2" SAE Flat Washer	4



Cradle and Steering ComponentsIn the box

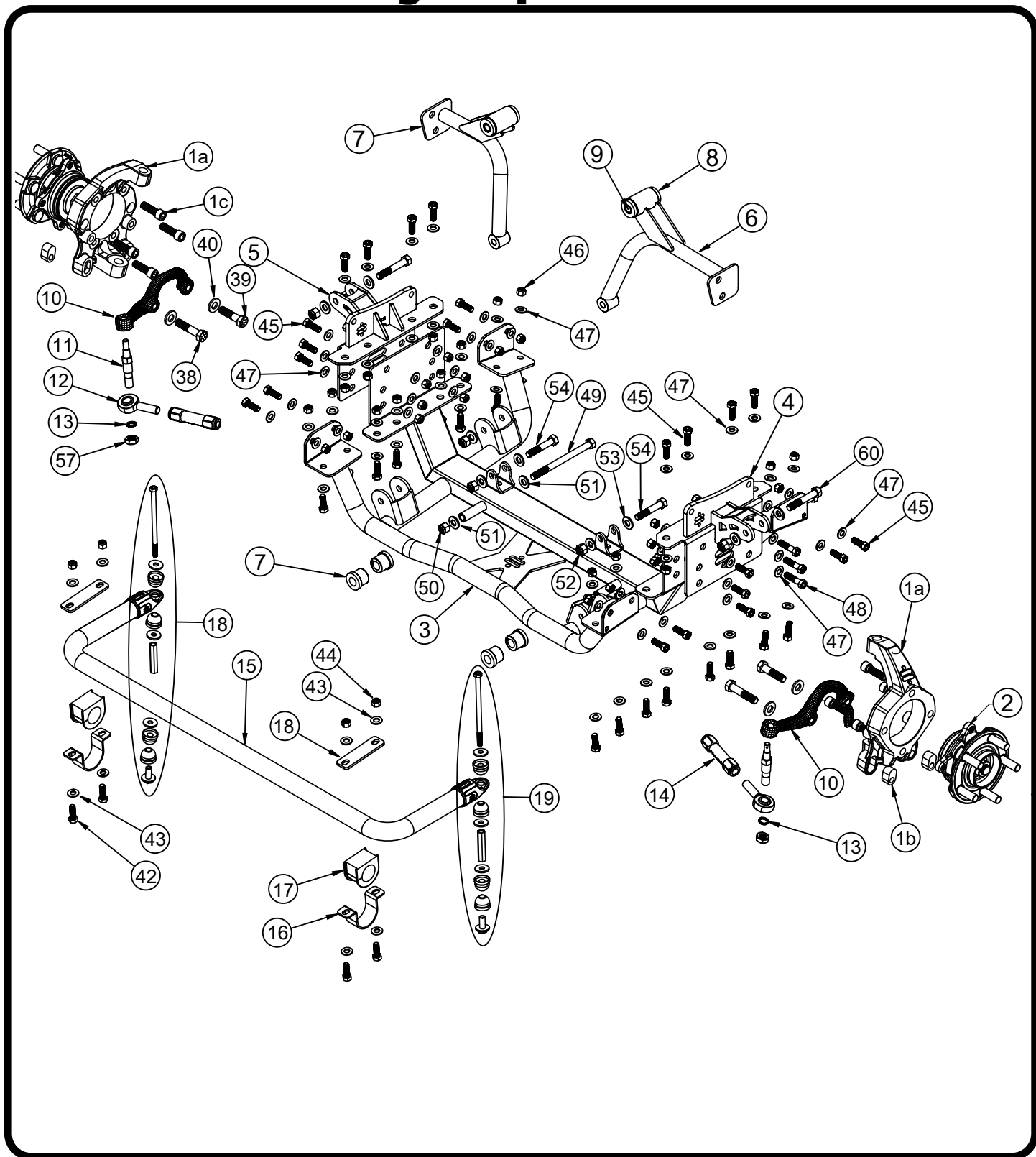



Control Arm ComponentsIn the box

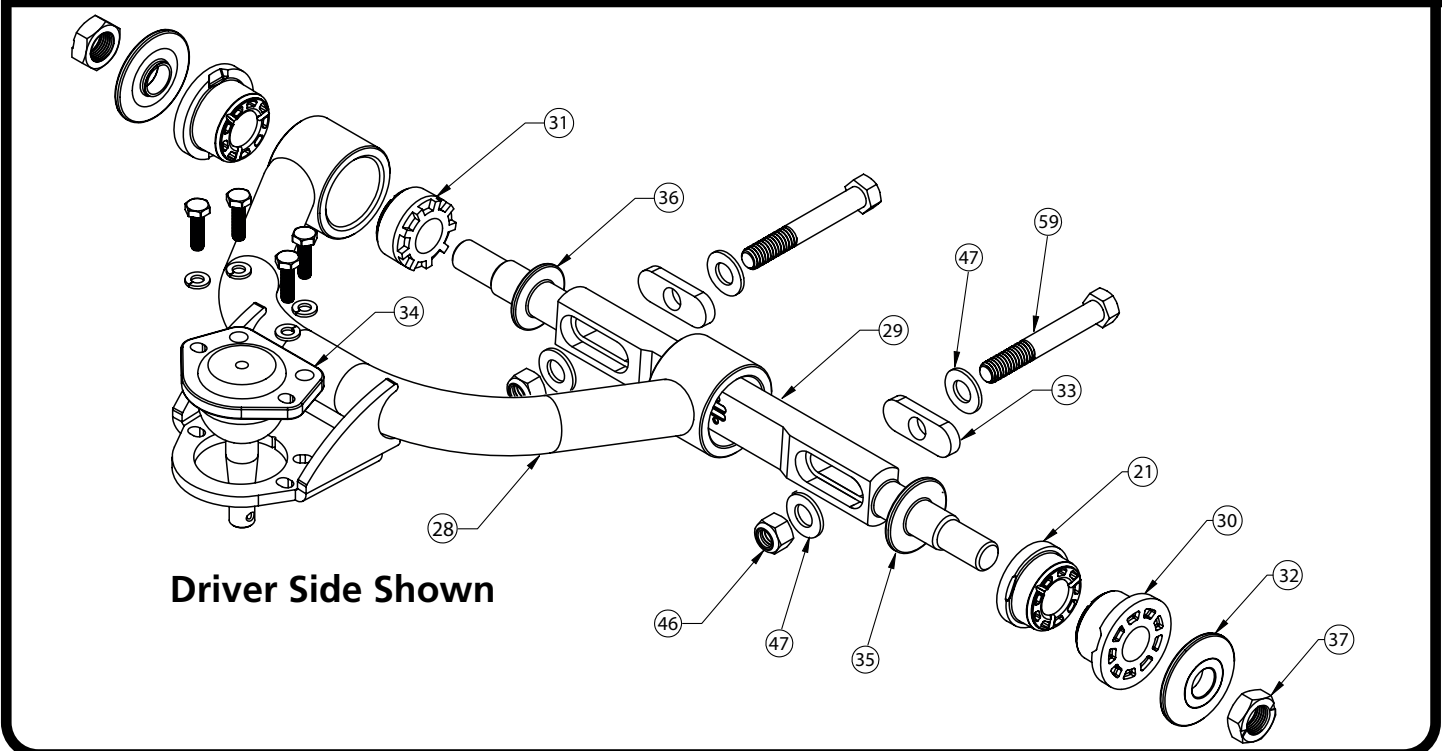
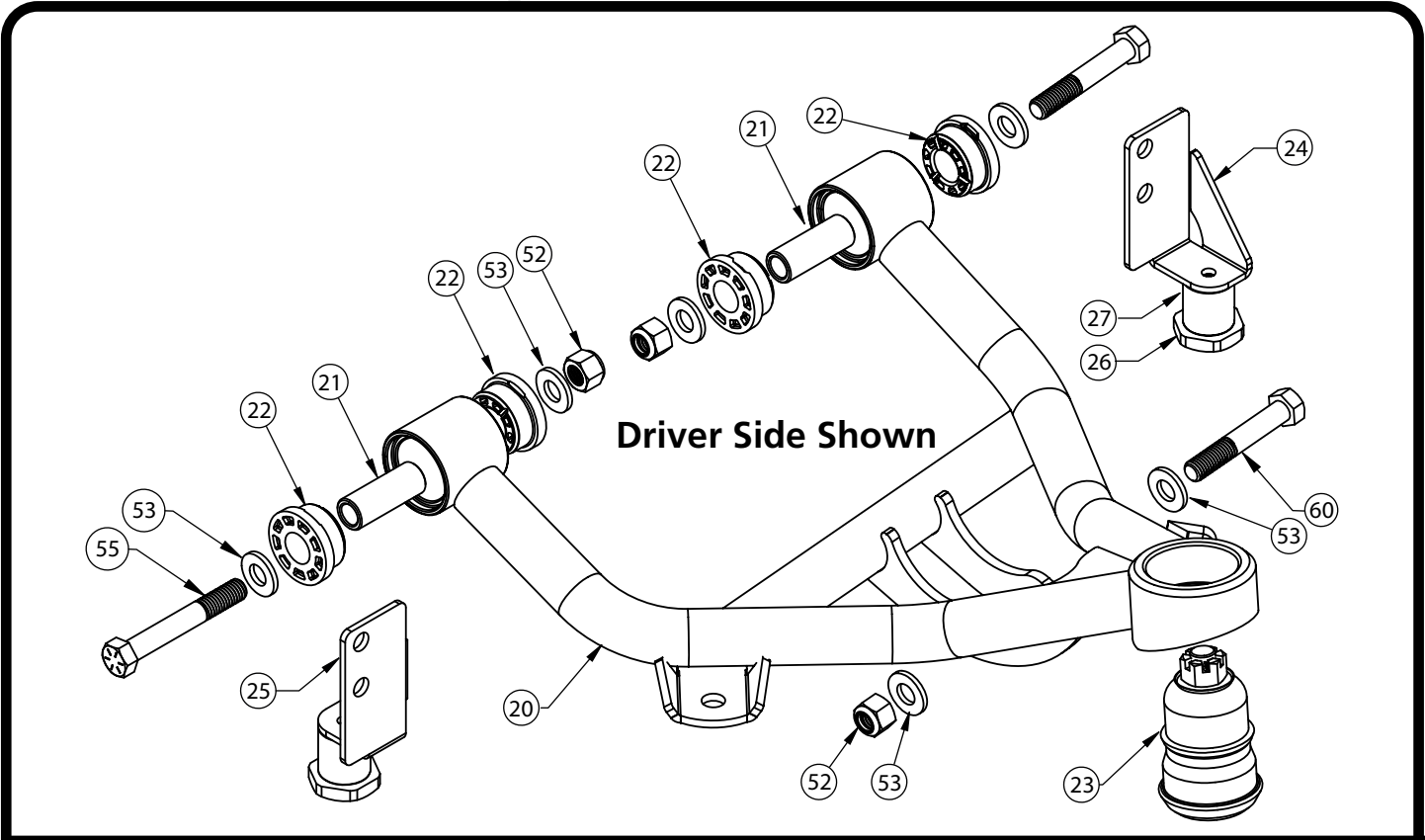



Hardware Kit ListsIn the boxes

THIS KIT INCLUDES (5) HARDWARE KITS. THE KITS ARE BROKEN DOWN ON THIS PAGE. THE HARDWARE KITS ARE LABELED AND BAGGED ACCORDING TO THE LOCATION THEY ARE USED. THESE LISTS, ALONG WITH THE DIAGRAMS ON THE PREVIOUS PAGES, WILL HELP GUIDE YOU WITH THE KIT INSTALLATION.

THE STEERING KIT CONTAINS KIT #S:
99010192
99010201
99010206

THE LOWER CONTROL ARM KIT CONTAINS KIT #:
99010204

THE LOWER CONTROL ARM KIT CONTAINS KIT #:
99010205

Kit #99010204

Item #	Part Number	Description	QTY
LOWER CONTROL ARM TO CRADLE			
52	99502009	1/2"-13 Nylok Nut	4
53	99503014	1/2" SAE Flat Washer	8
55	99501005	1/2"-13 x 3 1/2" Hex Bolt	4
BUMP STOP TO BRACKET			
56	99371001	3/8"-16 x 3/4" Hex Bolt	2
57	99373003	3/8" SAE Flat Washer	2
58	99373005	3/8" Split Lock Washer	2

Kit #99010205

Item #	Part Number	Description	QTY
UPPER CONTROL ARM TO MOUNT			
59	99431021	7/16"-14 x 3" Hex Bolt	4
46	99432010	7/16"-14 Nylok Nut	4
47	99433005	7/16" Flat Washer	8
SHOCK TO SHOCK MOUNTS			
60	99501004	1/2"-13 x 3" Hex Bolt	4
52	99502009	1/2"-13 Nylok Nut	4
53	99503014	1/2" SAE Flat Washer	8

Kit #99010192

Item #	Part Number	Description	QTY
SWAY BAR TO FRAME			
42	99371005	3/8"-16 x 1 1/4" Hex Bolt	4
43	99373002	3/8" Flat Washer	8
44	99372001	3/8"-16 Nylok Nut	4

Kit #99010201

Item #	Part Number	Description	QTY
CRADLE/UPPER ARM MOUNT TO FRAME			
45	99431021	7/16"-14 x 1 1/4" Hex Bolt	38
46	99432010	7/16"-14 Nylok Nut	44
47	99433005	7/16" Flat Washer	88
48	99431023	7/16"-14 x 1 3/4" Hex Bolt	6
RACK TO CRADLE			
49	99121017	M12-1.75 x 170mm Bolt	2
50	99122009	M12-1.75 Nylok Nut	2
51	99123002	M12 Flat Washer	4
MOTOR MOUNT TO CRADLE			
52	99502009	1/2"-13 Nylok Nut	2
53	99503014	1/2" SAE Flat Washer	4
54	99501064	1/2"-13 x 2 3/4" Hex Bolt	2

Kit #99010206

Item #	Part Number	Description	QTY
TIE ROD STUD			
61	99622006	5/8"-18 THIN Lock Nut	2
Not Shown	99432005	7/16" Castle Nut	2
Not Shown	99952002	3/32" Cotter Pin	2
TIE ROD ADJUSTER			
Not Shown	99562002	9/16"-18 Jam Nut	2
Not Shown	99800003	5/8"-18 LH Jam Nut	2



Brake Bracket ComponentsIn the box

Item #	Part #	Description	QTY
62	90003539	Caliper Bracket - Driver	1
	90003540	Caliper Bracket - Passenger (Not Shown)	1

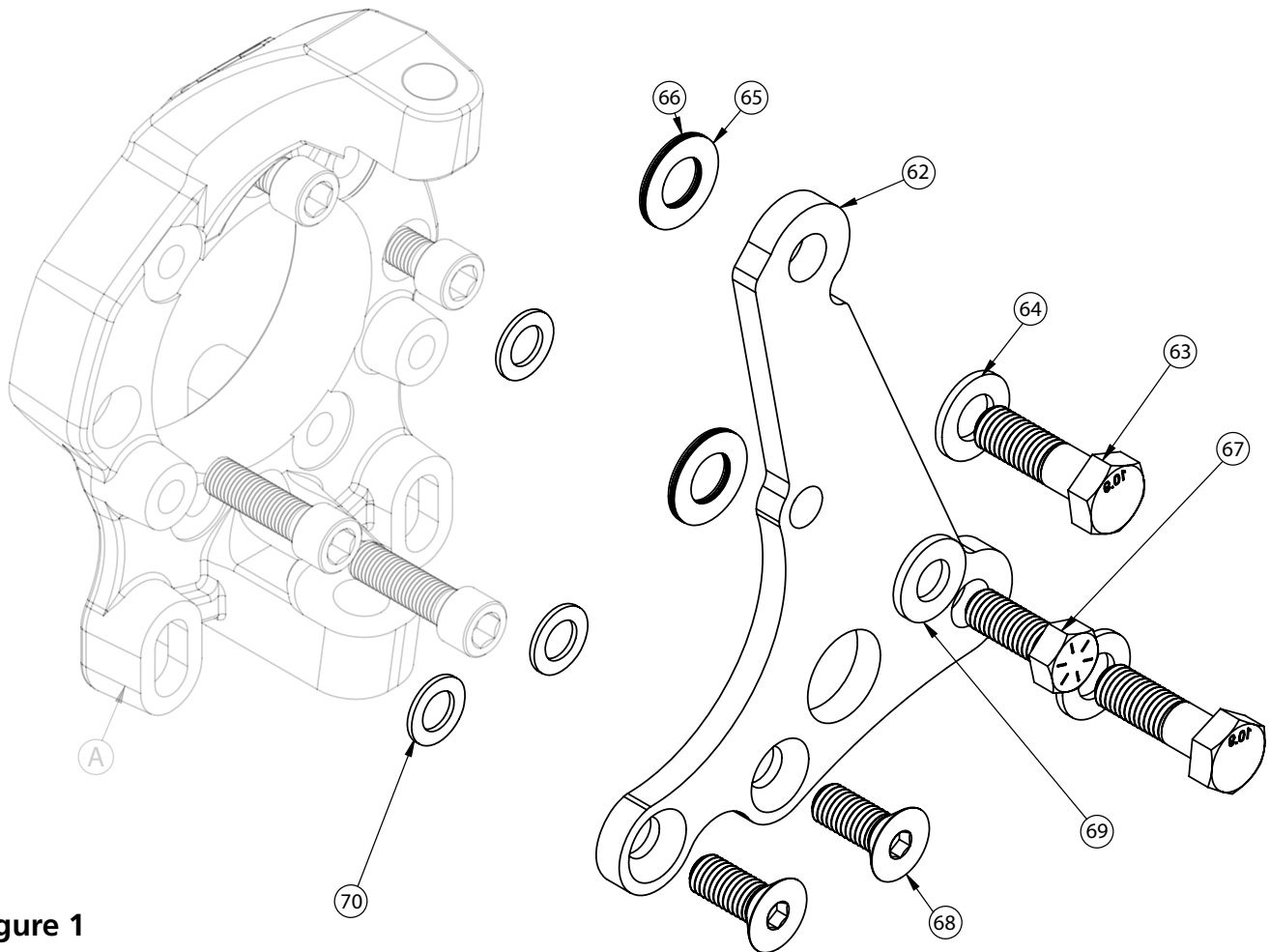

Figure 1

Hardware ListIn the box (Kit # 99010227)

Item #	Part Number	Description	QTY	Item #	Part Number	Description	QTY
BRACKET TO CALIPER				BRACKET TO SPINDLE			
63	99121005	M12-1.75 X 30mm Hex Bolt	4	67	99501062	1/2"-13 x 1 1/4" Hex Bolt	2
64	99123002	M12 Flat Washer	4	68	99501075	1/2"-13 x 1 1/4" FHSCS	4
SHIM PACK				69	99503014	1/2" SAE Flat Washer	2
65	99503018	Shim .016" thick, 1/2" ID	8	70	99503017	Shim .063" thick, 1/2" ID	6
66	99503019	Shim .032" thick, 1/2" ID	8				



Important Notes

This kit requires removal of the engine. It can not be installed with the engine in the truck.

If using the factory steering column, you will need U-Joint Kit # 12319505. If using an aftermarket column, the required components will differ depending on the column manufacturer.

This kit requires a Ridetech Motor Mount Kit. We have different kits for different engines.

Small Block Ford	12319501
Ford Modular Motor 4.6/5.4/ Coyote	12319503
Ford FE	12319504
GM Small Block/ Big Block/ LS	12319502

This suspension kit is designed to use a 1979-1993 Ford Mustang Rack and Pinion.

If your truck has drum brakes, a disc brake master cylinder will be required.

The OEM front crossmember needs to be cut out of the truck.

The radius arm crossmember will remain in the truck.

The Hub Bearing used in this kit is a 2015-2022 S550 Mustang hub bearing. It has a 5 on 4 1/2" bolt pattern for the wheel mounting. The studs of the hub bearing are 14mm.

The Caliper Brackets included in this kit are designed to use 2015-2022 S550 Front rotors and caliper/ caliper brackets. Any brake kit designed for the 2015-2022 Mustang should fit this kit.

Wheel Fitment: If you are planning on running more than 4 1/2" back spacing, this kit will require at least an 18" diameter wheel.

Disassembly

1. Remove the engine from the truck. The transmission can be left in the truck, but will need to be supported.
2. Remove the entire front suspension and steering from the truck. Refer to the factory service manual for disassembly procedure.
3. Remove the OEM steering box from the truck.



Disassembly



4. Remove the OEM engine mount stands.



5. The bottom rear of the OEM crossmember may have a bolt instead of a rivet. If so, remove the bolt.



6. The OEM upper coil spring and I-beam mounts need to be removed from the frame rail. This can be done by either drilling the rivets out or removing the rivet heads and driving them out. We remove the rivet heads by cutting a " + " in the head with a die grinder then we cut the head off with a hammer and chisel or with an air chisel. Once the head is removed, the rivet can be driven out with a hammer and punch.



Disassembly



7. Remove the side and bottom rivets from the frame mounts.



8. Remove the coil spring mount from the frame. Do this for both sides.



9. The OEM i-beam cross member will need to be cut out of the truck. It needs to be cut out even with the top of the frame rail. We also cut the cross member in the center for easier removal. We used a saw-z-all to cut the cross member out of the truck.



Disassembly



10. **Image 10** shows the cross member cut on the drivers side.

+



11. **Image 11** illustrates the cross member removed from the truck frame.



12. Cut the OEM steering box mount out of the frame by cutting it along the top and bottom frame rail.



Disassembly



13. Remove the steering box inner spacer. This mount can be removed by straightening the (2) tabs that stick through the frame.



14. The vertical sections that are inside the frame rail need to be removed. The frame surface needs to be flat. We cut these out using a die grinder and cut off wheel.



15. We grind the top of the cross member back to the frame rail.



Disassembly



16. The inside of the frame rails need to be ground smooth.



17. Your truck may have a brake line bracket right behind the coil spring mount that will need to be removed from the frame rail. This mount usually attaches with a rivet and bolt. Remove the bolt and rivet to remove the mount.



18. There is a pin that sticks down from the bottom of each frame rail that needs to be removed. These pins are in front of the OEM cross member. These need to be cut off even with the frame rail.



Disassembly



19. Smooth the outside of the frame rail. If you are planning to paint the frame rail, now is a good time to do it.

73-79 F100 ONLY!!! Cradle Installation



20. The 73-79 F100 trucks passenger frame rail has a section of the frame bent downward. This bent down area is in the location of the rear crossmember mount. This area needs to be flattened for cradle installation. The cradle can be lifted in position to mark the area that needs flattened.



21. We used an adjustable wrench to bend the flange flat. Tighten the adjustable wrench tight to the rail and use the wrench to bend it upward. You will need to work up and down the frame rail bending it up to get the frame rail flat.



Cradle Installation

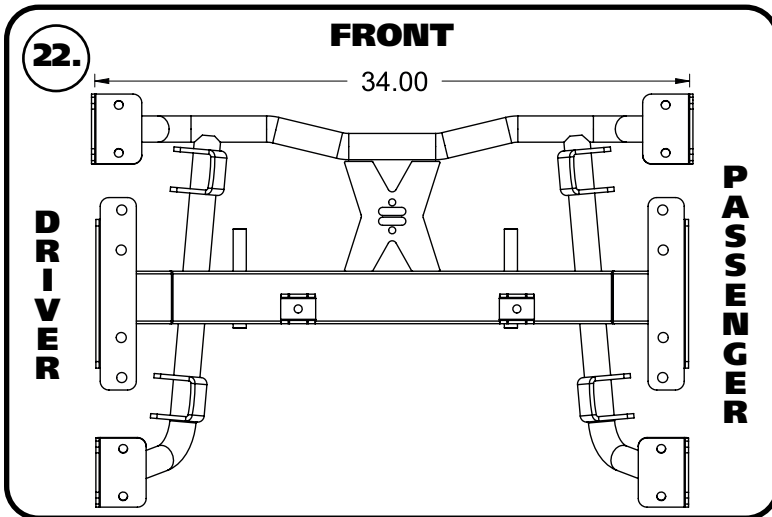

22. *Diagram 22* shows a top view of the cradle to illustrate which way it goes in the truck. The round tube of the cradle is to the front of the truck.



23. Raise the cradle up into position. The (6) holes in the large side plates will align with the (6) OEM rivet holes.



24. Position the cradle so that the (6) holes of the side plate align with the rivet holes in the frame.



Cradle Installation

25.

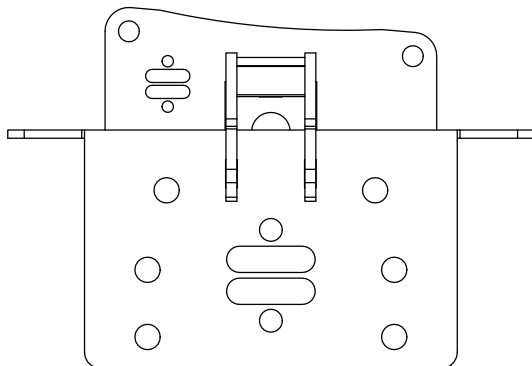

**DRIVER
SIDE**

25. Diagram 25 illustrates the Driver side upper control arm mount. This mount is mounted on the outside of the frame, over top the cradle. The (6) holes of the upper control arm mount, align with the cradle and frame holes.

26.



26. Install a 7/16" flat washer on each of (3) 7/16"-14 x 1/4" hex bolts. Insert a bolt in the front (3) bolt holes. Install a 7/16" flat washer and 7/16"-14 nylok nut on the threads of the bolt. This will help keep everything aligned. Do this for both sides.

27.



27. The kit contains a Driver and Passenger side engine mount. The frame side of the engine mount will align with the top (2) holes of the rear set of holes. The bushing side of the engine mount gets inserted into the mounts on the cradle tube. Position the engine mounts in place. Install a 1/2" flat washer on each of (2) 1/2"-13 x 2 3/4" hex bolts. Insert the bolt through the cradle mounts and bushings. Install a 1/2" flat washer and 1/2"-13 nylok nut on the threads of each bolt. Leave the hardware loose until later.



Cradle Installation



28. Install a 7/16" flat washer on a 7/16"-14 x 1 3/4" hex bolt. Insert the bolt in the top hole of the rear (3) bolt holes. This bolt will go through the upper control arm mount, cradle plate, & engine mount. Install a 7/16" flat washer and 7/16"-14 nylok nut on the threads of the bolt. **DO NOT INSTALL A BOLT IN THE LOWER HOLE OF THE ENGINE MOUNT HOLE AT THIS TIME.**



29. The bump stop mount attaches to the (2) lower holes of the rear (3) holes. The kit includes a Driver & Passenger bump stop mount. The gusset of the mount goes to the rear of the truck. Install a 7/16" flat washer on (2) 7/16"-14 x 1 3/4" hex bolts. Align the bump stop mount with the bottom (2) holes of the rear (3) holes. Insert the bolts in the mounting holes. The top bolt will go through the bump stop mount, upper control arm mount, cradle plate, & engine mount. The bottom bolt doesn't go through the engine mount. Install a 7/16" flat washer and 7/16"-14 nylok nut on the threads of the bolts. Do this for both sides. Thread the bump stop into the aluminum spacer. Attached the bump stop/spacer to the mount using a 3/8"-16 x 3/4" bolt, lock washer, and flat washer.



30. Install a 7/16" flat washer on each of (2) 7/16"-14 x 1 3/4" hex bolts. Insert the bolt/washers in the remaining bottom (2) bolts holes of the front (3) bolt holes. Install a 7/16" flat washer and 7/16"-14 nylok nut on the threads of the bolts. Do this for both sides. Snug the hardware, but do not torque the hardware at this time.



Cradle Installation



31. There are (8) mounting holes in the bottom mounts of each side of the cradle. All but (2) of these will need to be drilled with a 7/16" drill bit. (2) of the holes will align with factory holes.



32. Install a 7/16" flat washer on each of (8) 7/16"-14 x 1/4" hex bolts. Insert a bolt/washer in each bottom (8) holes. Install a 7/16" flat washer and 7/16"-14 nylok nut on the threads of the bolts. Again, snug the hardware down, but do not torque the hardware at this time. Do this for both sides.



33. Drill the (4) holes for the front & rear side frame mounts using a 7/16" drill bit.



Cradle Installation



34. Install a 7/16" flat washer on each of (4) 7/16"-14 x 1/4" hex bolts. Insert a bolt/washer in each of the (4) holes. Install a 7/16" flat washer and 7/16"-14 nylok nut on the threads of the bolts. Again, snug the hardware down, but do not torque the hardware at this time. Do this for both sides.



35. The top flange of the upper control arm mount has (4) mounting holes. (2) of these mounting holes will align with OEM holes. (2) need to be drilled with a 7/16" drill bit.



36. Install a 7/16" flat washer on each of (4) 7/16"-14 x 1/4" hex bolts. Insert a bolt/washer in each top (4) holes. Install a 7/16" flat washer and 7/16"-14 nylok nut on the threads of the bolts. Torque all 7/16" cradle hardware to 70 ft-lbs. Torque the 1/2" engine mount hardware to 75 ft-lbs.



Lower Control Arm Installation

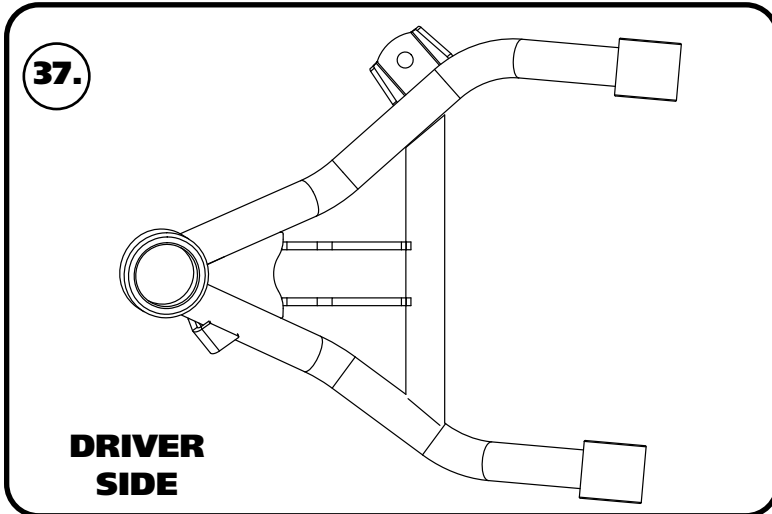

37. The lower control arms are marked "D" for Driver and "P" for Passenger. The ball joint pin points up and the sway bar mount is on the front side of the arm. **Diagram 37** shows a top view of the Driver lower control arm.



38. Insert the lower control arm in the mounts built in the lower cradle. Align the mounting holes of the lower mounts with the through hole of the bushing sleeves.



39. Install a 1/2" flat washer on each of (2) 1/2"-13 x 3 1/2" hex bolts. Insert the bolt/washer in the aligned holes with the threads to the rear of the truck. Install a 1/2" flat washer & 1/2"-13 nylok nut on the threads of the bolts. Repeat on the passenger side control arm. Torque the mounting bolts to 75 ft-lbs.



Caster Explained

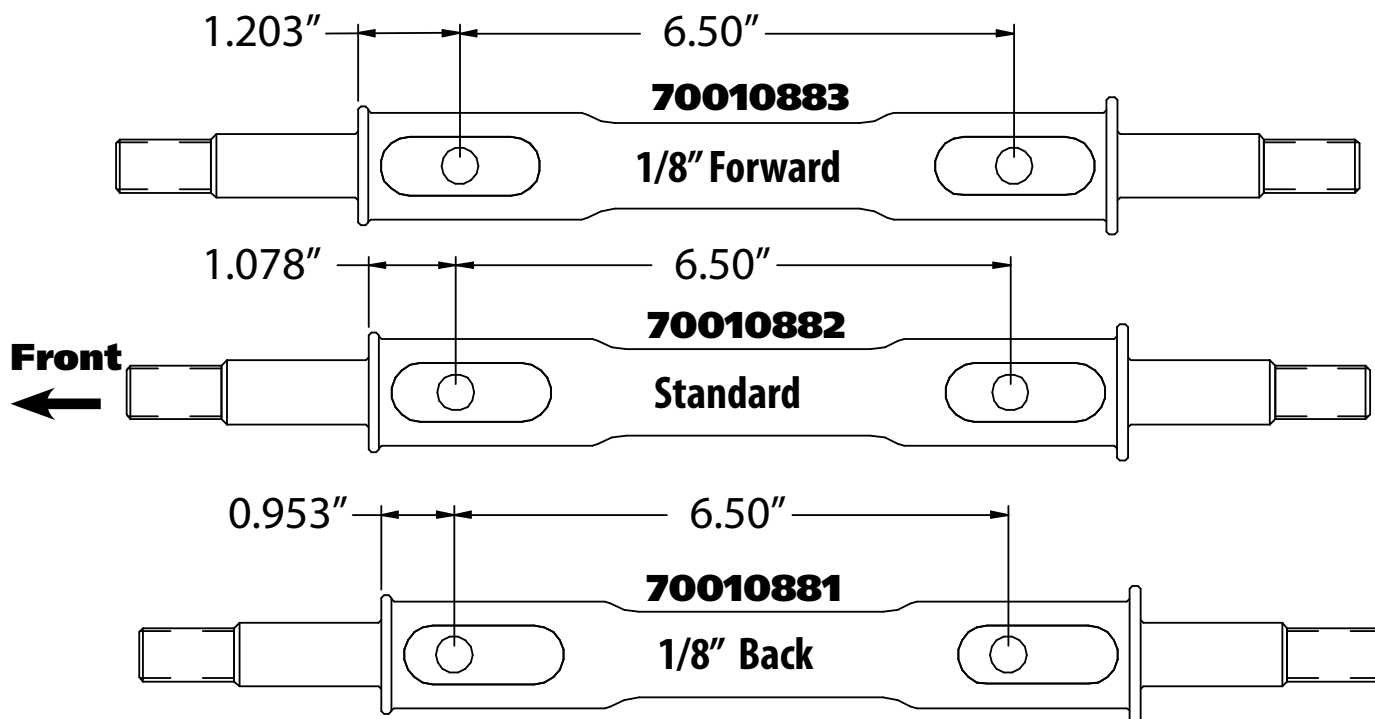

These StrongArms come equipped with a changeable caster slug setup. This allows you to add or remove caster from the front suspension, if desired. The caster slugs that come supplied in the kit are standard (70010882). The caster slugs allow you to add or remove caster without having to use a stack of shims. If more or less caster is desired, optional slugs can be purchased from Ridetech or your Ridetech dealer.

1/8" Forward = 70010883

1/8" Back = 70010881

Caster Explained:

To understand caster you need to picture an imaginary line that runs through the upper ball Joint and extends through the lower ball Joint. From the side view the imaginary line will tilt forward or backward. The tilting of this imaginary line is defined as caster.

Caster is measured in degrees by using a caster gauge. If the imaginary line described above tilts towards the back of the vehicle at the top, then you have positive caster. If the imaginary line tilts forward then you have negative caster.

Positive caster provides the directional stability in your vehicle. Too much positive caster will make the steering effort difficult. Power steering will allow you to run more positive caster. Negative caster requires less steering effort but will cause the vehicle to wander down the highway



Offset Upper Control Arm Shaft

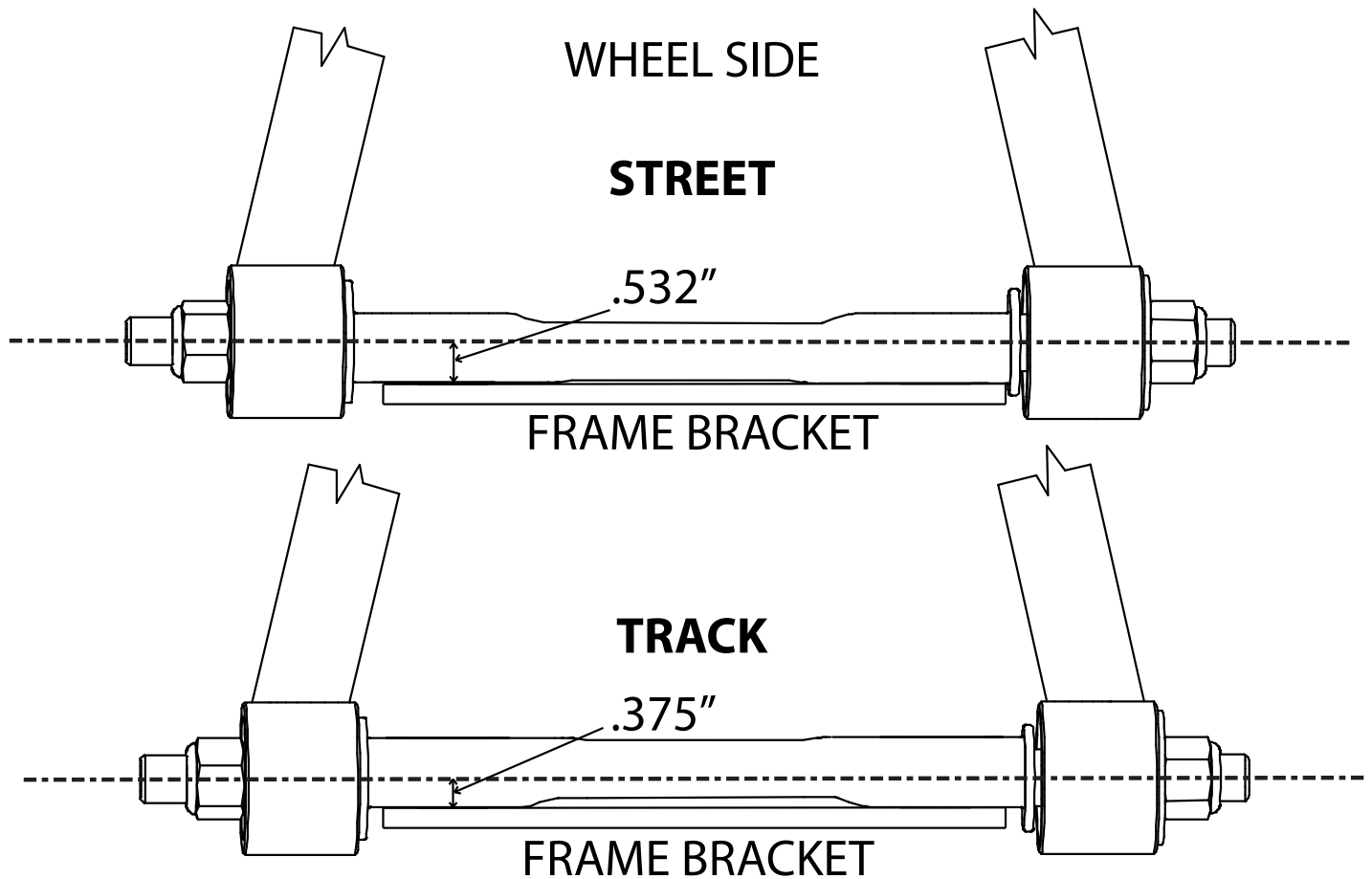

The cross shaft that is used in the upper control arms is offset. The offset combined with the caster slug option allows you to achieve the alignment setting you desire with minimal shims. To change the direction the Icon faces simply spin the cross shaft in the control arm.

If you are after a **Street Alignment** bolt the upper control arm to the frame mount with the arm offset to the outside of the truck. The Ridetech Icon will be facing the wheel.

If a more aggressive **Track or Autocross** alignment is desired, bolt the control arm to the frame bracket with the arm offset to the inside of the truck. The Ridetech Icon will be facing the frame rail.



Upper Control Arm Installation

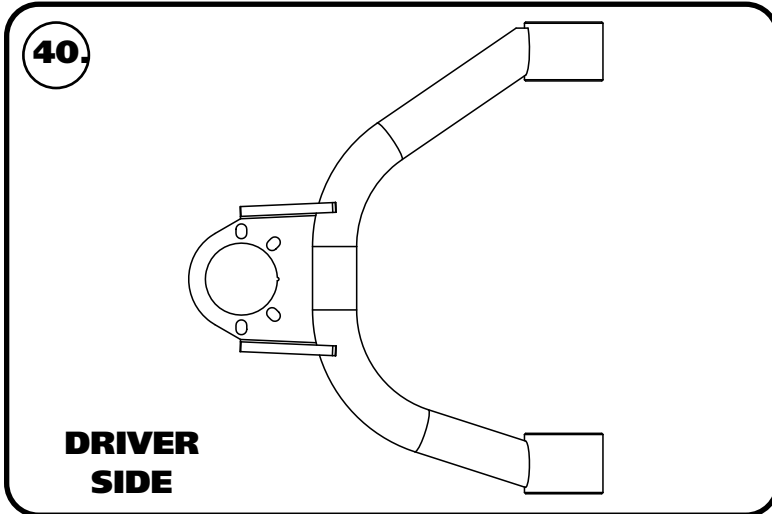

40. The upper control arms are marked "D" for Driver and "P" for Passenger. The ball joint pin points down and the ball joint is to the rear of the truck. **Diagram 40** shows a top view of the Driver upper control arm.



41. Install a 7/16" flat washer on each of (2) 7/16"-14 x 3" hex bolts. Insert a bolt/washer in each bottom (2) upper control arm mounting holes.

Note: 73-79 F100s might require you to push the inner fender out of the way to install the front upper bolt.



42. Insert the caster slug into the cross shaft using the guide on **Page 21** as a guide. **The long side of the caster slug will be to the rear of the control arm.** Slip the upper control arm onto the mounting bolts using **Page 22** as a guide for cross shaft orientation. Install a 7/16" flat washer & 7/16"-14 on the threads of each bolt. Torque the bolts to 70 ft-lbs.



Shock Installation



If installing CoilOvers, refer to the CoilOver instructions for shock assembly.

43. Insert the shock bearing t-bushings into the bearing of the eyelet. The small outside diameter of the t-bushing will insert into the shock bearing.



44. Insert the eyelet of the shock into the frame mount with the adjuster knob toward the outside of the truck. Align the mounting holes with the through hole of the shock eyelet.



45. Install a 1/2" flat washer on a 1/2"-13 x 3" hex bolt. Insert the bolt/washer into the mount/shock. Install a 1/2" flat washer & 1/2"-13 nylok nut. Torque the hardware to 75 ft-lbs.



Shock Installation



46. Insert the shock bearing t-bushings into the bearing of the shock body. The small outside diameter of the t-bushing will insert into the shock bearing.



47. Swing the lower control arm up to the shock. While swinging the control arm up, insert the shock body into the shock mount of the control arm. Align the mounting holes with the through hole of the shock body.



48. Install a 1/2" flat washer on a 1/2"-13 x 3" hex bolt. Insert the bolt/washer into the mount/shock. Install a 1/2" flat washer & 1/2"-13 nylok nut. Torque the hardware to 75 ft-lbs.



Rack Installation



49. Install one half of a poly rack bushing on the rack mounting bung of the cradle. The bushing needs to be installed on the bung with the large diameter against the cradle. Install a bushing on each mounting bung.



50. Install the rack on the bushing half. The steering shaft will be on the drivers side with the shaft pointing toward the cab.



51. Insert the 2nd half of the rack bushings into the rack. Do this for each mount.



Rack & Spindle Installation



52. Install a M12 flat washer on a M12-1.75 x 170mm hex bolt. Insert the bolt/washer into the rack mount. Install a 1M12 flat washer & M12-1.75 nylok nut. Torque the hardware to 93 ft-lbs.



53. THESE SPINDLES ARE SYMMETRICAL, THEY AREN'T SIDE SPECIFIC UNTIL THE STEERING ARM IS BOLTED ON. Install the spindle on the lower ball joint. Install the ball joint castle nut on the stud of the ball joint.

Torque Specs:

Lower Ball joint - 65 ftlbs and tighten to line up cotter pin.

Install the Cotter Pin after tightening the ball joint nut.



54. Insert the top ball joint into the spindle.

Torque Specs:

Upper Ball Joint - 50 ftlbs and tighten to line up cotter pin.

Install the Cotter Pin after tightening the ball joint nut.



Hub Bearing Installation



55. The Hub is attached to the spindle using (4) M12-1.50 x 40 SHCS. Apply RED Loctite to each of the mounting bolts. Insert them into the correct holes and Torque to 99 ftlbs.



The steering arms will **NOT** get attached to the knuckle until the brakes are attached. Refer to the caliper bracket instructions for proper assembly.

Getting Started.....

These brackets are designed around OEM 2015-2022 S500 Mustang brakes. Aftermarket brakes that are designed for these cars will also fit this spindle.

Caliper Bracket Installation

Caliper bracket and brake mounting will differ depending on the brake kit being used.

We recommend mocking up the brakes with clean dry threads before applying any loctite to the hardware. The brake bracket kits include shims for mounting the caliper brackets and calipers. The caliper brackets will use 1/2" ID .063" thick shims. This kit includes 2 different thicknesses of shims for caliper mounting, .016" and .032" thick.

The next steps will cover the installation of caliper brackets on the Ridetech spindle. **Again, mock up the brake kits with clean dry threads before using any loctite on the hardware.** We are showing the installation of the caliper bracket with the spindle off the car so it can be shown clearly.



56. Lay a .062" thick, 1/2" ID shim on each of the caliper brackets (3) mounting holes.



Caliper Bracket Installation



57. The caliper brackets are side specific. They have a D & P stamped in them. Lay the correct side caliper bracket on top of the shims, aligning the mounting holes with the mounting holes of the bracket. The counter sunk holes should facing up.



58. Insert a 1/2"-13 x 1 1/4" flat head socket cap screw in each of the lower mounting holes. Install a 1/2" flat washer on a 1/2"-13 x 1 1/4" hex bolt and insert it in the upper mounting hole. Tighten the hardware to 75 ft-lbs.



59. Install the rotor on the hub. Thread some lug nuts on the threads of the hub to hold the rotor tight on the hub.



Caliper Bracket Installation



60. The OEM caliper bracket will bolt to the spindle mount. Install a M12 flat washer on each of (2) M12-1.75 x 30mm hex bolts. Insert the bolts through the caliper bracket. Line the caliper mount up with the hardware and thread in the bolts.



61. You can use feeler gauges to measure the distance between the caliper bracket and rotor to make sure the bracket is centered as much as possible. If the caliper mount is tighter on the back side, put shims on the caliper bracket/spindle. If the caliper bracket is tighter on the front side, put shims between the caliper bracket/caliper mount. After you are happy with the fitment, the hardware will need to red loctite and torqued. Torque the 1/2" bracket to spindle hardware to 80 ft-lbs. Torque the M12 hardware to 69 ft-lbs.

Note: If you are installing aftermarket brakes, refer to the brake kit instructions for measuring the caliper placement.



62. Install the brake pads and caliper.



Steering Arm Installation

The threaded steering arm inserts can be mounted in 2 different positions. **Image 52** will help you determine the correct position for the installation on your vehicle. This position is what we determined to be the best with the Ridetech suspension.

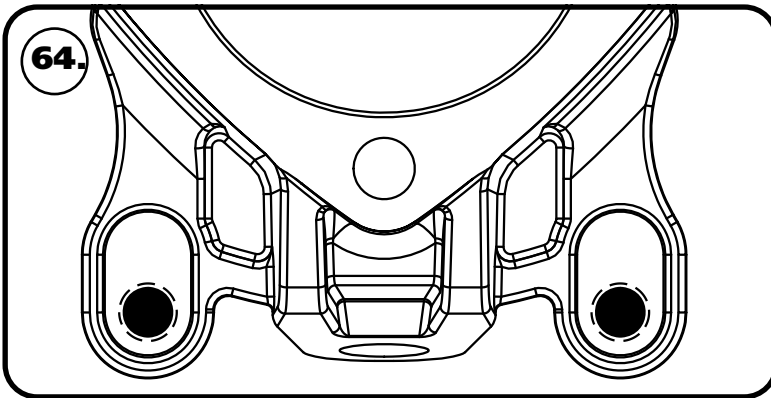

64. Bottom Position:
65-79 Ford F100 Ridetech Suspension

The next 2 Images are shown with the spindle off the truck to show greater detail.

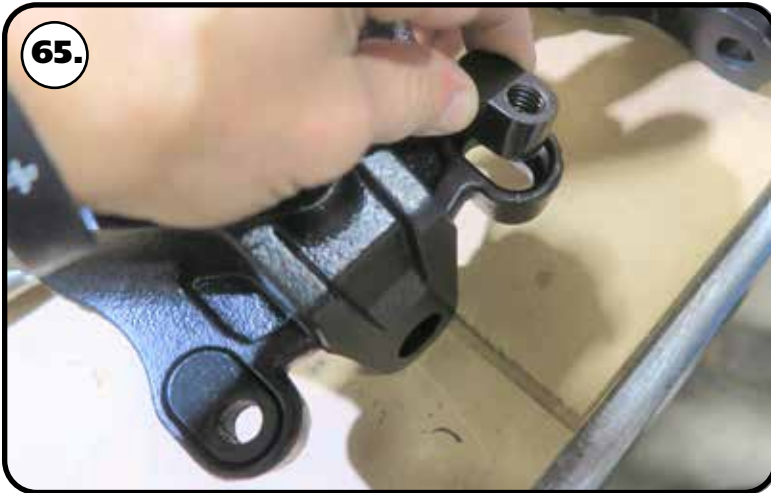

65. Insert the steering arm slugs into the spindle with the threads to the bottom of the spindle,



66. Hold the steering arm slugs in place. Align the mounting holes of the steering arm with the threaded holes of the slugs. Driver side steering arm is shown in **Image 66**. The tie rod end curves in to the inside of the truck. Install a 1/2" flat washer on a 1/2"-13 x 2" & 1/2"-13 x 2 1/4" hex bolts. The 1/2"-13 x 2 1/4" bolt will go in the hole closest to the tie rod end. Apply red loctite to the threads of the bolts before threading into the slugs. It is the thicker side of the mounts. Insert a bolt in each steering arm hole and thread them into the steering arm slugs. Torque to 80 ft-lbs. Repeat on other steering arm/spindle. Make sure the end of the bolt is sticking out of the slug.



Steering Linkage Installation



67. Install the stud with the hex into the steering arm with the taper going into the steering arm. Install the 7/16"-20 castle nut onto the tie rod stud. Torque the nuts to 35 ftlbs and tighten as needed to align cotter pin hole and install cotter pin.



68. The tie rod adjusters have (2) different thread sizes, 5/8"-18 LH & 9/16"-18. The left hand threaded heim will thread into the 5/8"-18 end. The rack threads into the 9/16"-18 end. Install the 5/8"-18 LH jam nut on the heim end. Install a 9/16"-18 jam nut on the threads of the rack. Thread the heim into the adjuster and thread the adjuster onto the rack.



69. Next, slip the heim end onto the tie rod stud.



Steering Linkage & Sway Bar Installation



70. Install a 1/8" thick aluminum on the bottom side of the heim end followed by a 5/8"-18 thin nylok nut on the stud. Torque the nut to 45 ft-lbs.



71. Use a tape measure to put a mark on the frame **4 1/4"** from the front edge of the cradle mount. Align the back edge of the sway bar mounting strap with the mark on the frame. Hold the mounting strap in the center of the frame and mark the center of each mounting hole. The mounting holes need to be marked on each frame rail.



72. Drill the holes using a 3/8" drill bit.



Sway Bar Installation



73. Open the sway bar bushing at the split and slip it onto the sway bar. Do this for both bushings.



74. Install the bushing mounting strap on the sway bar bushing.



75. The sway bar includes a backer plate that needs to be installed on the top side of the frame flange. Align the backer plate holes with the holes drilled in the frame.



Sway Bar Installation



76. Install a 3/8" flat washer on each of (4) 3/8"-16 x 1 1/4" hex bolts. Hold the sway bar in place and insert a bolt in the mounting hole of the mounting strap. Install a 3/8" flat washer & 3/8"-16 nylok nut on the threads of the bolt. Repeat this on remaining mounting holes. Do NOT tighten the mounting bolts at this time. They need to left loose until the sway bar linkage has been attached to the lower control arm.



77. Install the end links using **Diagram 67** as a reference. Install both end links before tightening the end link hardware.



78. Tighten the end link barrel nut until it is flush with the end of the bolt, and then tighten it 2-3 more complete rounds. Torque the frame bolts to 45 ft-lbs.



Finishing & Alignment

79. Double check the hardware to make sure everything is tight.
80. Attached the steering column to the rack and pinion.
81. Install your front brake kit.
82. Attach the correct engine mounts to the engine and reinstall the engine.
83. **FINISH PLUMBING THE BRAKE SYSTEM AND BLEED THE SYSTEM.**
84. The truck will need to be aligned.

Suggested Alignment Specs:

Camber:	Street: -.5 degrees
Caster:	Street: +3.0 to + 5.0 degrees
Toe:	Street: 1/16" to 1/8" toe in



Part # 12313510

1965-1979 Ford F100 HQ Front CoilOvers

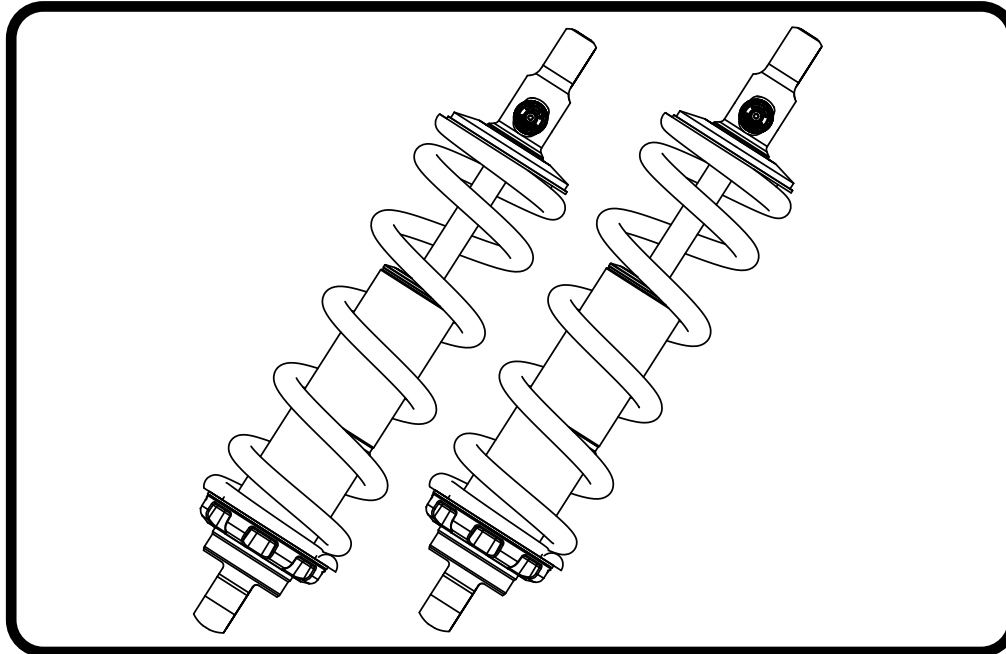

Recommended Tools

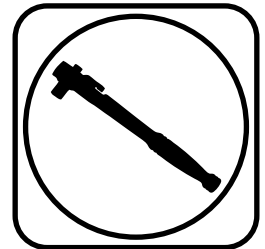

1965-1979 Ford F100 HQ Series Front CoilOvers

Installation Instructions

Table of contents

Page 41..... Included Components

Page 42..... Assembly and CoilSpring Adjustment

Page 43..... CoilSpring and Shock Adjustment

CoilOver Dimensions:

Center of bearing to Center of bearing:

Compressed: 11.13"

Ride Height: 13.50"

Extended: 15.23"

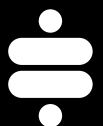



Major ComponentsIn the box

Item #	Part #	Description	QTY
1	982-10-804	4.1" Stroke HQ Series Shock	2
2	90002025	2.7" Shock Eyelet	2
3	803-00-109(kit)	Upper CoilSpring Retaining Plate (803-00-109 kit)	
4	59100750	Coilspring 10" 750lb	2
5	70010828	Delrin Spring Washer	4
6	803-00-109(kit)	Lower Spring Adjuster Nut (803-00-109 kit)	2
7	803-00-109(kit)	Adjuster Nut Locking Screw (803-00-109 kit)	2
8	803-00-109(kit)	Retaining Ring (803-00-109 kit)	2
9	90002040	1/2" ID Shock Bearing Spacer Half	8
	90001994	5/8" ID Bearing (installed in shock and eyelet)	4
	90001995	Bearing Snap Ring (installed in shock and eyelet)	8

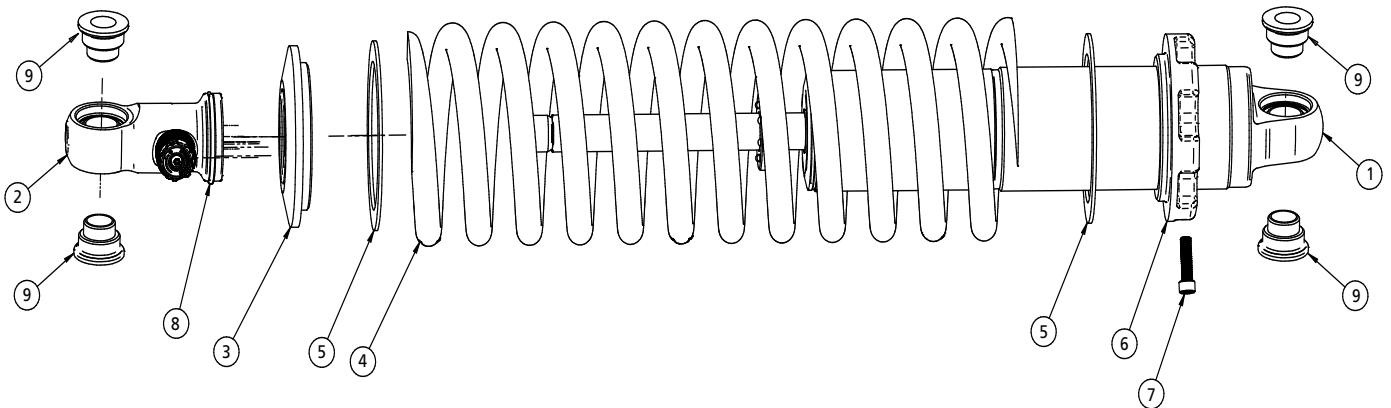



CoilOver Assembly...



1

First, using the supplied lower adjuster nut (803-00-199) thread the nut onto the shock from the bottom side as seen in figure 1. Remove the plastic pellet that is in the split of the adjuster nut.



4

Once the knob is removed slide a Delrin washer over the eyelet. Next, slide the upper spring mount (803-00-199) over eyelet as seen in figure 4.



2

Next, install a delrin washer then coil spring over the top of the shock as seen in figure 2.



5

Install upper spring mount retainer clip (803-00-199) into the groove on the upper eyelet as seen in figure 5. Then, reinstall adjuster to complete assembly.



3

Before the upper spring mount can be installed screw the adjuster knob on the upper eye mount to the firmest setting (clockwise) as seen in figure 3. Then remove the Knob by holding it while removing the center screw.

Install the locking screw in the adjuster nut before setting spring preload, but DO NOT tighten until the spring preload has been set.

NOTE: Remember to adjust the shock valving before driving, the shock is currently set to full stiff.

CoilSpring Adjustment

6. Preload the springs of the CoilOver 3/4" to start. **Steps 6a - 6e** will assist you with preloading the coil spring. You may need to adjust the amount of preload in the spring, but this will be determined after the vehicle has been sat on the ground.

6a. Verify the adjuster nut locking screw is installed in the adjuster nut, but not tight.

6b. Thread the spring adjuster nut up the shock body until it is snug against the spring. You should NOT be able to move the spring up and down on the shock (0 preload). Verify the upper coil spring cap is seated correctly on the upper shock stud.

6c. Measure from the bottom of the adjuster nut to the flat of the shock. You may want to write the measurement down.

6d. Using a spanner wrench, thread the adjuster up the shock an additional 3/4" (from the measurement you took in step 2) to preload the spring.

6e. Lock the adjusting nut in place by tightening the adjuster nut locking screw.

7. Reinstall the rear wheels and tires and set the rear of the vehicle back on the ground.

8. After entire weight of vehicle is on the wheels, jounce the suspension and roll the car forward and backward to alleviate suspension bind. **THIS IS NECESSARY BEFORE MEASURING RIDE HEIGHT.**



CoilSpring Adjustment

9. If you determine you need to adjust the ride height of the rear suspension after getting the vehicle on the ground, **Steps 9a - 9e** will assist you in adjusting the ride height.
 - 9a. Raise the vehicle and support it by the frame, allowing the suspension to hang freely. You do NOT need to remove the rear wheels.
 - 9b. Loosen the locking screw in the adjuster nut, but do not remove the locking screw.
 - 9c. Measure from the bottom of the adjuster nut to the flat of the shock. You may want to write the measurement down.
 - 9d. Using a spanner wrench, thread the adjuster up or down the shock to obtain the correct ride height. One complete revolution of the adjuster nut is approximately 1/8" at the wheel. Threading the adjuster nut up the shock will raise the ride height, threading it down will lower the ride height.
 - 9e. Lock the adjusting nut in place by tightening the adjuster nut locking screw.
10. After entire weight of vehicle is on the wheels, jounce the suspension and roll the vehicle forward and backward to alleviate suspension bind. **THIS IS NECESSARY BEFORE MEASURING RIDE HEIGHT.**
11. Recheck your ride height. If you need to readjust, repeat **Steps 9-10.**

Shock Adjustment 101- Single Adjustable

Rebound Adjustment:

How to adjust your new shocks.

The rebound adjustment knob is located on the top of the shock absorber, protruding from the eyelet. You must begin at the ZERO setting, then set the shock to a medium setting of 12.



-Begin with the shocks adjusted to the ZERO rebound position (full stiff). Do this by rotating the rebound adjuster knob clockwise until it stops.

-Now turn the rebound adjuster knob counter clockwise 12 clicks. This sets the shock at 12. Settings 21-24 are typically too soft for street use.

Take the vehicle for a test drive.



-If you are satisfied with the ride quality, do not do anything. You are set!

-If the ride quality is too soft, increase the damping effect by rotating the rebound knob clockwise 3 clicks.

Take the vehicle for another test drive.



-If the vehicle is too soft, increase the damping effect by rotating the rebound knob clockwise 3 additional clicks.

-If the vehicle is too stiff, rotate the rebound adjustment knob counter clockwise 2 clicks and you are set!

Take the vehicle for another test drive and repeat the above steps until the desired ride quality is achieved.



Part # 12327199

1965-1972 Ford F100 Rear Bolt-On 4-Link Suspension System

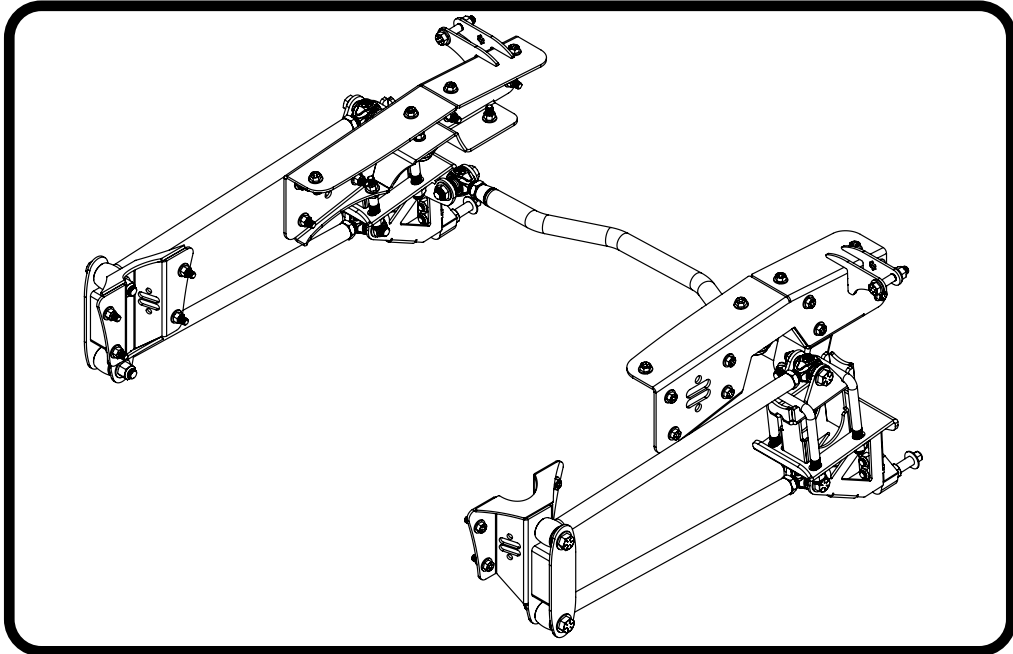

Recommended Tools

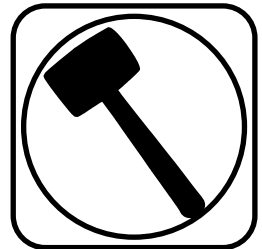

1965-1972 Ford F100 Rear Suspension Installation Instructions

Table of contents

Page 45-46.....	Included Components
Page 47-48.....	Hardware List & Disassembly
Page 48-52.....	C-Notch Installation
Page 52-53.....	Front Bar Mount Installation
Page 53-54.....	Axle Mount Installation
Page 55.....	Lower Shock Mount Installation
Page 55-56.....	Upper Bar Installation
Page 56-57.....	Installing Lower Bars
Page 58.....	Panhard Bar Installation
Page 58-59.....	Shockwave/CoilOvers Installation





Major ComponentsIn the box

Item #	Part Number	QTY	Description
1	90003403	1	65-72 F100 Driver C-Notch
2	90003404	1	65-72 F100 Passenger C-Notch
3	90003405	1	65-72 F100 Driver Lower Bar Ax
4	90003406	1	65-72 F100 Passenger Lower Bar
5	90003407	2	65-79 F100 Upper Axle Bar Mount
6	90003408	2	65-72 F100 4-Link Bar Mount
7	90002820	2	BARTW21.750 Parallel 4-link bar
8	90003409	2	BARTW 22.00 SET LENGTH 23.875
9	90003410	1	65-72 F100 Panhard Bar Assembly
10	90001318	5	PE - R-Joint 3/4-16 RH x 5/8 B
11	99752004	5	3/4-16 HEX FIN JAM NUT ZINC
12	90001086	2	DAYM03519-BK Black poly bushing
13	90002895	1	.625ID X .750OD X 2.00L INNER
14	70013334	2	R-Joint Spacer - 5/8" ID
15	90001624	2	SKW005 Aluminum SKW 4-link mount
16	90001617	2	S0001 5/8" od shock stud
17	90002067	4	Aluminum Spacer - .625" I.D. x .450"
18	99626005	4	U-Bolt 5/8-18 3.13W x 6.06L,
19	90002043	4	Aluminum Spacer, .500" ID x .365"
20	70013882	16	R-Joint Spacer - 5/8" ID .625
21	70015643	2	Bump Stops
22	70013275	4	R Joint Center Ball 30mm OD x 5/8" bolt
23	70013276	4	5/8" Swivel Joint Snap Over B
24	70013279	4	RETAINING RING,SINGLE-TURN 302
25	70013280	4	1.25" WAVO WAVE SPRING 17-7 PH
26	70015360	1	65-72 F100 Driver Notch Template
27	70015361	1	65-72 F100 Passenger C-Notch Template
	99010203	1	Hardware Kit: 65-79 F100 Rear



Major ComponentsIn the box

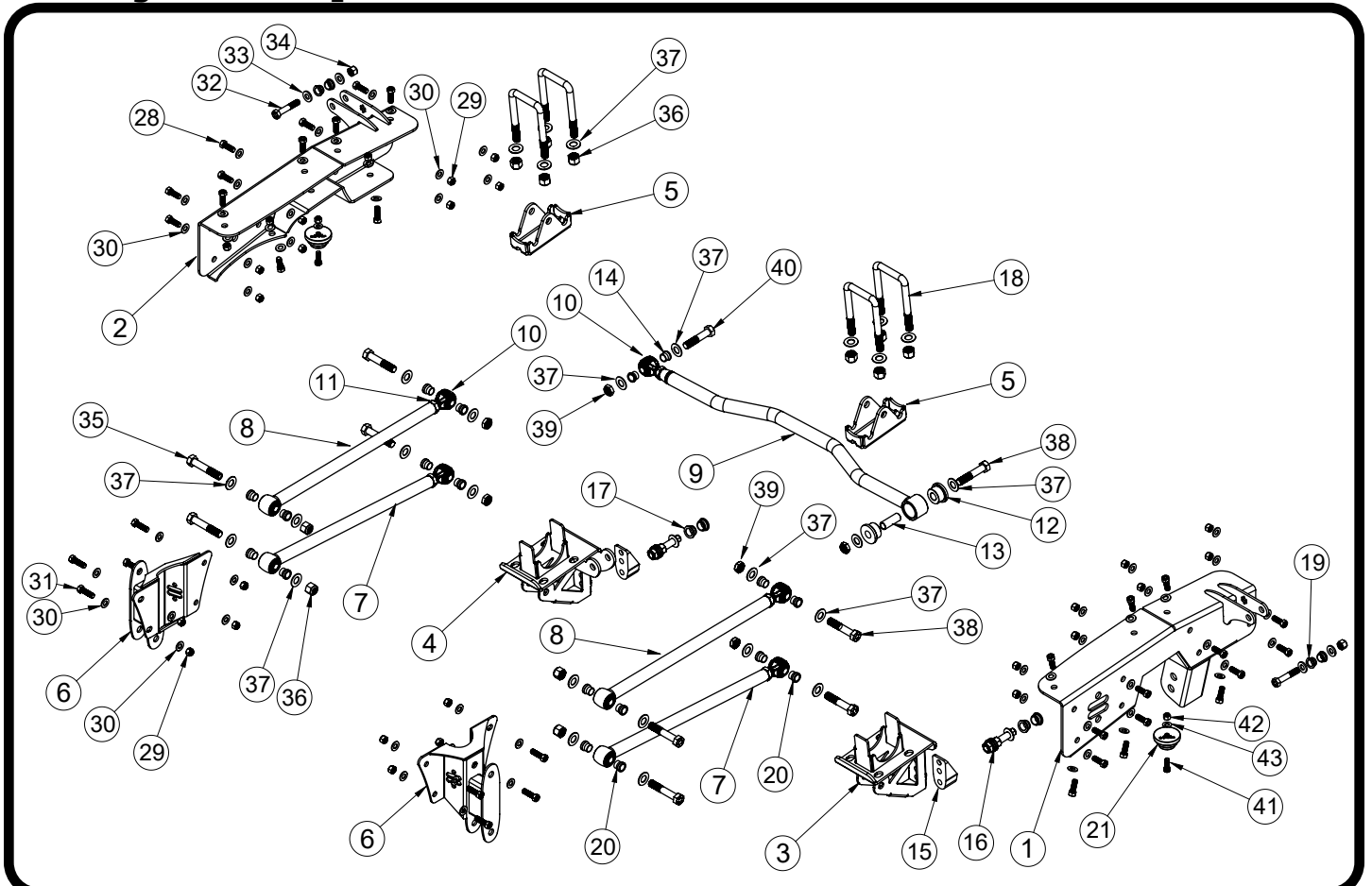

R-JOINT SPACER INSTALLATION

Install the Spacers by inserting the SMALL side of the SPACER into the Center Pivot Ball. Push them in until they bottom out and stop.

ALL R-JOINTS

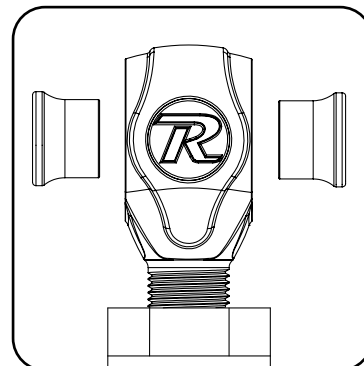

New R-Joints will be quite stiff (75-90 in/lbs breakaway torque) until they "break in" after a few miles of use. After the break in period they will move much more freely. Because the composite bearing race contains self lubricating ingredients, no additional lubrication is needed or desired. Any additional lubrication will only serve to attract more dirt and debris to the R-Joint and actually shorten its life.



Hardware ListIn the box (Kit# 99010203)

The Hardware Kit contains bags to help aid in selecting the correct hardware for the component being installed. The hardware list shows how the hardware is bagged.

Item #	C-NOTCHES TO FRAME		QTY
28	99431021	7/16-14 x 1 1/4" GR8 Hex Bolt	28
29	99432010	7/16-14 GR8 Nylok Nut	28
30	99433005	7/16" SAE Washer	56
	FRONT 4-LINK TO FRAME		
29	99432010	7/16-14 GR8 Nylok Nut	8
30	99433005	7/16" SAE Washer	16
31	99431022	7/16-14 x 1 1/2" GR8 Hex Bolt	8
	SHOCK TO C-NOTCH		
32	99501064	1/2-13 X 2 3/4 Hex Bolt Gr. 8	2
33	99503014	1/2 SAE FLAT WASHER GR8 YZ	4
34	99502009	1/2-13 USS Gr. 8 NYLOK NUT	2
	BARS TO FRONT MOUNT		
35	99621005	5/8-18 X 3 1/2 Hex Cap Screw Z	4
36	99622001	5/8 NYLOK GR8 NUT	4
37	99623001	5/8 SAE WASHER	8
	U-BOLTS		
36	99622001	5/8 NYLOK GR8 NUT	8
37	99623001	5/8 SAE WASHER	8
	BARS TO AXLE MOUNTS		
37	99623001	5/8 SAE WASHER	8
38	99621018	5/8-18 X 3 1/4 Hex Cap Screw Z	4
39	99622006	5/8-18 THIN NYLON JAM NUT GRAD	4
	PANHARD MOUNTS		
37	99623001	5/8 SAE WASHER	4
38	99621018	5/8-18 X 3 1/4 Hex Cap Screw Z	1
39	99622006	5/8-18 THIN NYLON JAM NUT GRAD	2
40	99621004	5/8-18 X 3 Hex Cap Screw Zinc/	1
	BUMPSTOP TO C-NOTCH		
41	99371034	3/8-16 x 1 SOC CAP BOLT	2
42	99372002	3/8-16 GR 5 NYLON INSERT L/N G	2
43	99373002	3/8 SAE FLAT WASHER ZINC/YELLO	2
	LOWER SHOCK MOUNT		
	99501009	1/2"-20 X 1 3/4" BOLT GR8	2
	99501007	1/2"-20 X 1 1/4" BOLT GR8	2
	99502002	1/2"-20 NYLOK NUT GR8	4

Disassembly

Congratulations on your purchase of the Ridetech Rear 4 Link System. This system has been designed to give your truck excellent handling along with a lifetime of enjoyment. Some of the key features of this system: C-notches to give your suspension the travel it needs at the lowered height, 4Link setup to replace the leaf spring and provide better control of the rear axle, and the biggest feature of all, it allows the use of Shockwaves or CoilOvers.



Disassembly

Note: This system is designed for use with the Ridetech Shockwaves or CoilOvers. **The factory shocks and springs will not fit this 4Link.**

1. Raise the vehicle to a safe and comfortable working height and support it by the frame. You will need to be able to move the rear differential up and down. Use a jack under the rear axle so it can be raised and lowered as needed during the install.
2. **Remove the bed, retaining the hardware for reassembly. This kit can NOT be installed with the bed on. The bed requires minor modifications before reinstalling it.**
3. Remove the leaf springs and shock absorbers.

"C" Notch Installation



4. The OEM bump stop mounts will need to be removed from the frame rail. This can be done by either drilling the rivets out or removing the rivet heads and driving them out. We remove the rivet heads by cutting a " + " in the head with a die grinder then we cut the head off with a hammer and chisel or with an air chisel. Once the head is removed, the rivet can be driven out with a hammer and punch. After removing the frame mounts, drill the rivet holes with a 7/16" drill bit.

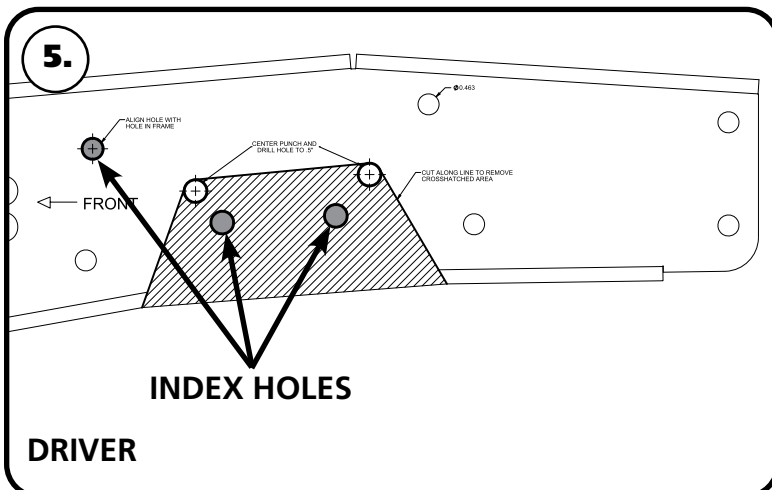

5. To allow maximum drop on this truck, the frame must be notched. Cutting templates are supplied with the kit to aid in cutting the frame. The template for the notch will locate off of the 3 holes that are grayed out in **Diagram "5"**. Before cutting out the frame, support the frame in front of and behind the "C" Notch area. We suggest doing one side at a time. The template has an Arrow on them that will point to the front of the truck. **Check the inside of the frame for wires or lines before drilling or cutting.**



"C" Notch Installation

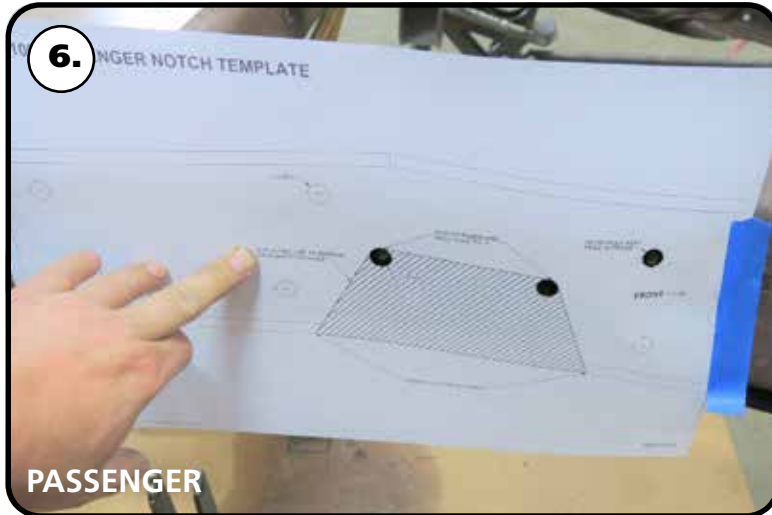

5. Cut the indexing holes out of the template and align them with the holes in the frame. We recommend taping the c-notch to the frame to hold it in position.

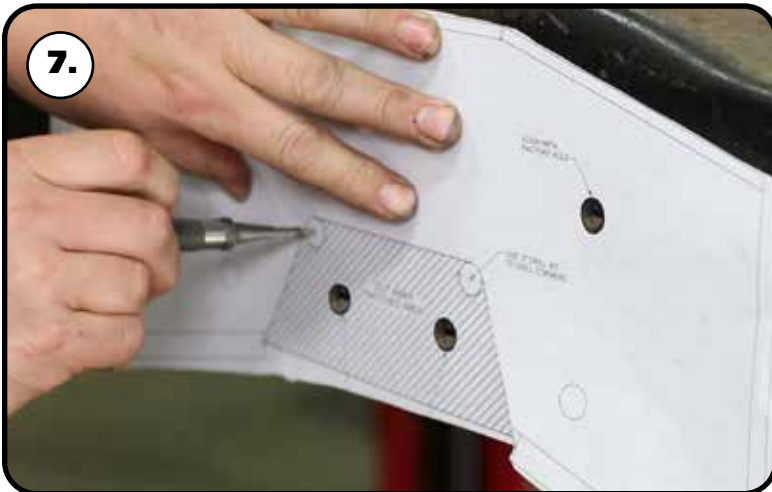

6. Use the template to center punch the corner holes of the area that needs to be cut out.

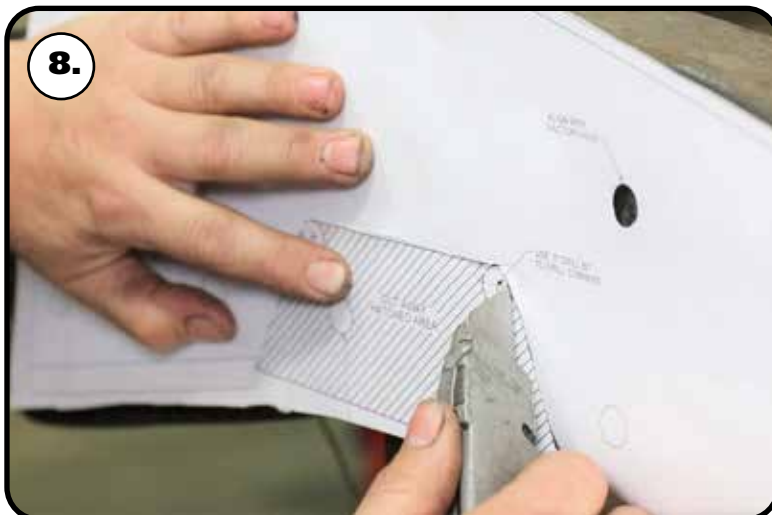

7. Use a razor knife to cut along the outer lines of the hashed area of the template. With the hashed area cut out, use the template to mark the frame rail for cutting the c-notch.



"C" Notch Installation

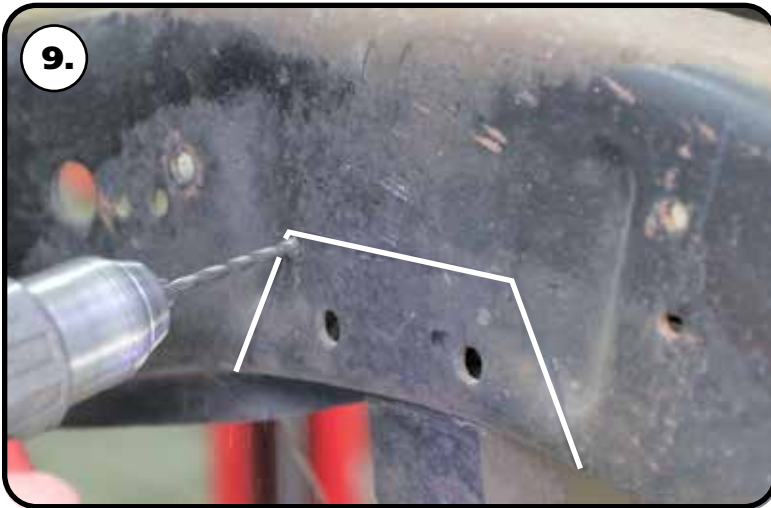

8. The corner holes will need to be drilled with a 1/2" drill bit, but we recommend drilling the corner holes with a smaller drill bit first.



10. Drill the holes using a 1/2" drill bit. This will give the corner a round edge and eliminate the possibility for stress fractures



11a & 11b. Cut the notch with a saw-z-all, cutoff wheel, or plasma cutter. Grind all edges smooth. Cut the sides of the frame and across the bottom of the rail. The cuts on the bottom of the frame rail will be parallel with each other. The side frame cuts will blend into the drilled holes. The section of frame will fall out when cutting is complete.



"C" Notch Installation



11b. The section of frame will fall out when cutting is complete.

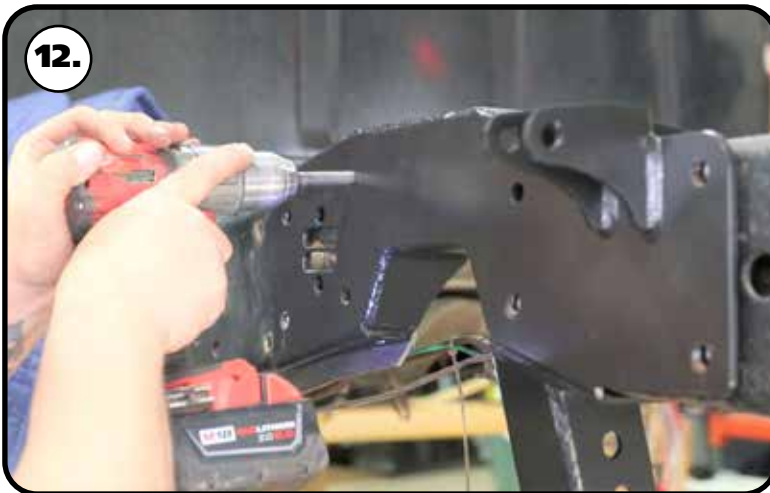

12. After cutting, slip the c-notch over the frame to check the fitment. The cut areas of the frame may require grinding for the c-notch to fit. The c-notch will be used as a template to drill the remaining mounting holes. Use a 7/16" Drill bit to drill the holes in the side of the frame. There are 8 holes in the side that need to be drilled.



13. Install a 7/16" flat washer on each of (8) 7/16" x 1 1/4" bolts. This hardware gets installed in the sides of the c-notch. Install a 7/16" flat washer and 7/16" nylok nut on each bolt sticking through the frame. Tighten all of the c-notch side bolts. Tighten the hardware snugly for the time being.



"C" Notch & Front Bar Mount Installation



14. Use a 7/16" drill bit to drill the remaining holes in the top and bottom of the frame.



15. Install a 7/16" flat washer on each of (6) 7/16" x 1 1/4" bolts. This hardware gets installed in the top & bottom of the c-notch. Install a 7/16" flat washer and 7/16" nylok nut on each bolt sticking through the frame. Tighten the c-notch mounting hardware to 70 ft-lbs.



16. Install the bump stop using a 3/8"-16 x 1" socket head bolt, 3/8" flat washer, & 3/8"-16 nylok nut. Hold the bump stop with your hand and insert the bolt through the center of the bump stop. Line up the bolt of the bump with the drilled hole of the frame. Install a 3/8" flat washer and 3/8" nut on the threads of the bolt. Tighten to 60 **in-lbs**.

Repeat Steps 4-16 on the other side.



Front Bar Mount & Axle Mount Installation



17. The OEM front leaf spring mounts will need to be removed from the frame rail. This can be done by either drilling the rivets out or removing the rivet heads and driving them out. We remove the rivet heads by cutting a " + " in the head with a die grinder then we cut the head off with a hammer and chisel or with an air chisel.



18. Once the head is removed, the rivet can be driven out with a hammer and punch. After removing the frame mounts, drill the rivet holes with a 7/16" drill bit.



19. The front bar mounts bolt in place of the OEM front leaf spring mount. The Driver and Passenger mounts are the same. **Image 19** shows the Driver mount installed. The mounting holes will line up with the mounting holes of the OEM front leaf spring hanger. Install a 7/16" flat washer on (4) 7/16" x 1 1/2" bolts. Hold the mount in place and insert the bolts/washer through the mount and frame. Install a 7/16" flat washer and 7/16" nylok nut on each bolt sticking through the frame and tighten to 70 ftlbs. Repeat on the other side.



Axle Mount Installation



20. Sit the upper bar mount on the leaf spring pad of the axle. The locating pin needs to insert into the leaf spring locating hole of the leaf spring pad.



21. The kit includes a Driver and Passenger lower axle mount; the two are different. The Passenger mount has the panhard bar mount built into it. **Image 21** shows the Passenger mount. Hold the mount up in place against the bottom of the axle tube. The tabs will nest against the bottom of the leaf spring pad.

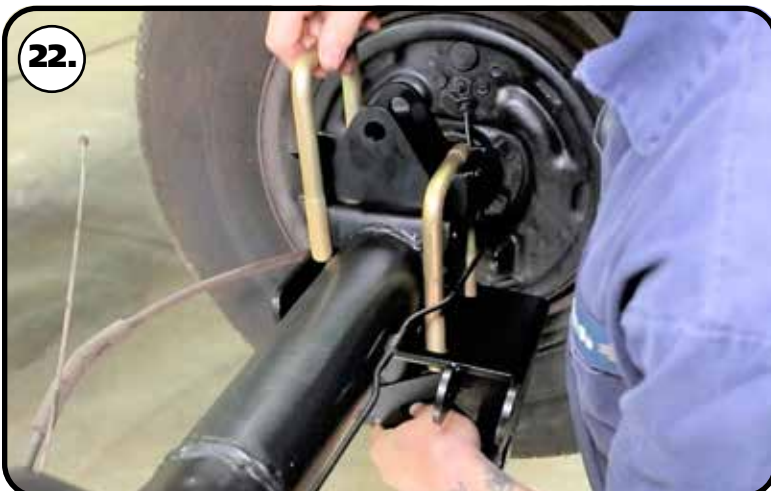

22. Install a supplied 5/8" u-bolt in each side of the upper bar mount. The u-bolts will nest in the slots of the upper mount. The U-bolts will run parallel to the axle tube.



Lower Shock Mount & Upper Bar Installation



23. Hold the mount in place and install a 5/8" flat washer and 5/8"-18 nylok nut on the threads of the u-bolts sticking through the axle mount. Tighten the nuts evenly in a criss-cross fashion making sure the tabs of the axle mount are touching the leaf spring pad evenly. Torque the nuts in a criss-cross fashion to 75 ftlbs. Repeat on the other side.



24. The lower shock mount attaches with (1) 1/2"-13 x 1 1/4" hex bolt, (1) 1/3"-13 x 1 3/4" hex bolt, & (2) 1/2" flat washer, & (2) 1/2"-13 nylok nuts. The lower mount gets attached to the 2nd and 3rd hole up from the bottom of the axle mount. When the shock mount is installed correctly, the bottom of the lower shock mount is 1/2" below the bottom of the axle mount. Insert the bolts through the aluminum shock mount with the 1 1/4" long bolt in the top hole, 1 3/4" in the bottom hole.



25. Insert the bolts through the axle mount and install the flat washers & nylok nuts on the threads sticking through. Repeat on both sides and torque the bolts/nuts to 75 ftlbs. Install a 5/8" flat washer onto the 5/8"-18 threads of the shock stud. Apply Red Loctite to the 5/8" threads of the stud. Thread the shock stud into the threaded hole of the lower mount. Repeat on both sides and torque the shock stud to 65-75 ftlbs.



Installing Upper & Lower Bars



26. Insert (2) .625" ID x .740" long R-Joint spacers into the R-Joint of one end of each 23 7/8" center to center upper bar. The small diameter of the spacer goes into the R-joint. Insert the front of the upper bar R-Joint into the front mount. The front mount has 2 bar mounting locations. The 23 7/8" upper bar needs to be installed into the top position.



27. Line the through hole of the R-Joint with the of holes of the frame mount. Install a 5/8" flat washer on to a 5/8"-18 x 3 1/2" hex bolt, insert into the lined up holes. Install a 5/8" flat washer followed by a 5/8"-18 nylok nut. Repeat on both sides and tighten the bolts/nuts enough to eliminate any gaps.



28. Insert the .625" ID x .740" long R-Joint spacers into the rear of the upper bar with the small OD inserted into the R-joint. The small diameter of the spacer goes into the R-joint. Insert the rear upper bar R-Joint into the upward axle mount. Line the through hole of the R-Joint with the of holes of the upper axle mount. Install a 5/8" flat washer on to a 5/8"-18 x 3 1/4" hex bolt, insert into the lined up holes. Install a 5/8" flat washer followed by a 5/8"-18 THIN nylok nut. Repeat on both sides and tighten the bolts/nuts enough to eliminate any gaps.



Installing Lower Bars



29. Insert (2) .625" ID x .740" long R-Joint spacers into the R-Joint of one end of each lower bar (23 5/8"). The small diameter of the spacer goes into the R-joint. Insert the rear lower bar R-Joint into the lower bar mount built into the axle mount.



30. Line the through hole of the R-Joint with the of holes of the bar mount. Install a 5/8" flat washer on to a 5/8"-18 x 3 1/4" Hex bolt, insert into the lined up holes. Install a 5/8" flat washer followed by a 5/8"-18 THIN nylok nut. Repeat on both sides and tighten the bolts/nuts enough to eliminate any gaps.



31. Insert (2) .625" ID x .740" long R-Joint spacers into the front R-Joint of each lower bar. The small diameter of the spacer goes into the R-joint. Insert the front lower bar R-Joint into the lower position of the frame mount.



Panhard Bar & Shockwave/Coilover Installation

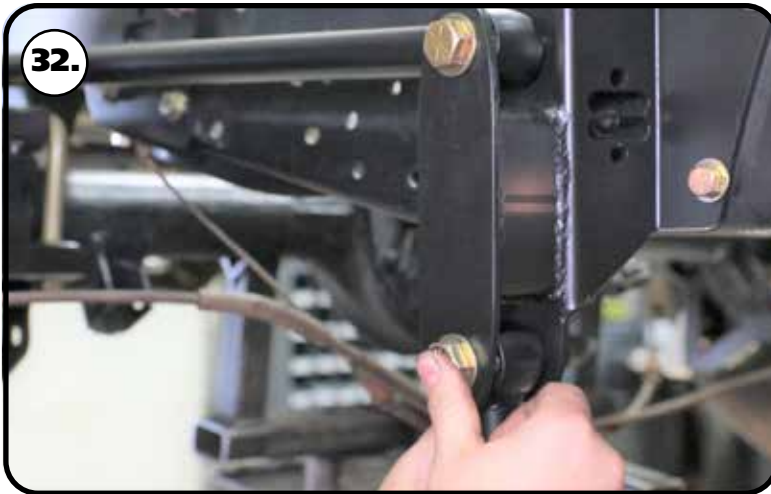

32. Line the through hole of the R-Joint with the of holes of the front frame mount. Install a 5/8" flat washer on to a 5/8"-18 x 3 1/2" hex bolt, insert into the lined up holes. Install a 5/8" flat washer followed by a 5/8"-18 nylok nut. Repeat on both sides and tighten the bolts/nuts enough to eliminate any gaps.



33. Remove the bolt that attaches the brake hose to the bracket. This will allow you to move the brake line out of the way to cut the bracket off the axle tube.



34. We used a die-grinder with a cutoff wheel to cut the brake line bracket off the axle tube. Be careful not to cut into the axle tube.



Shockwave/Coilover Installation



35. Insert the 1/2" ID Shock Bearing Spacers into the Bearing of the ShockWave/CoilOver. Install a 1/2" Flat Washer on a 1/2"-13 x 2 3/4" Bolts. Insert the top of the shock into the shock mount on the c-notch with the adjusting knob to the outside. Line up the holes and insert the bolt/washer. Install a 1/2" Flat Washer and 1/2"-13 Nylok Nut on the threads and tighten to 50 ftlbs.



36. The Shock Stud requires spacers that are .400" long (90002067). Install a 5/8" ID 90002067 spacer (**Small side towards shock body**) onto the lower Shock Stud. Slide the bottom of the Shock onto the Stud. Install a second 5/8" ID 90002067 Spacer onto the Stud (**small side towards shock**). You may need to jack the rear end up to Slide the Shock onto the Stud.



37. Install the 7/16" Flat washer and 7/16" Nylok nut. Tighten the upper and lower shock bolts. Torque the Upper Bolt to 50 ftlbs and the Lower Nut to 40 ftlbs. The designed ride height of the CoilOver/Shockwave is 14 1/2" center to center.

38. Reinstall the bed.

39. Verify all hardware is tight.

40. Set ride height on the truck. The ride height of the Shockwave/CoilOver is approximately 14 1/2". If you are using Shockwaves, this is done by changing the air pressure in the Shockwaves. If you are using CoilOvers, the ride height is done by using the adjuster nut for the coil spring. The coil spring on the CoilOver will have some preload in the spring to get ride height, this is normal.



Part # 12316510

1965-1979 Ford F100 HQ Rear CoilOvers

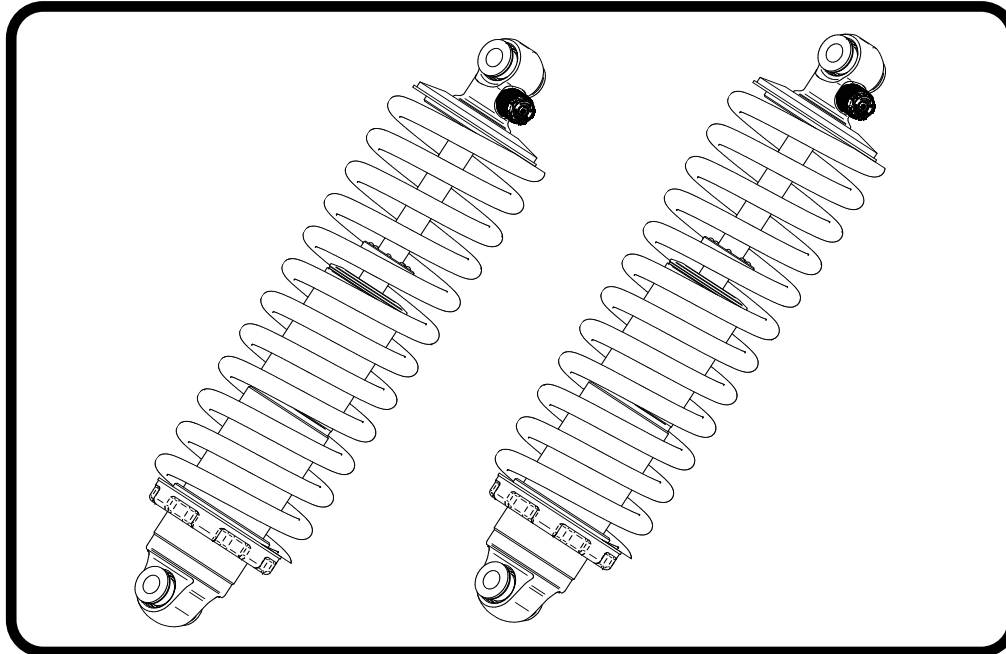

Recommended Tools

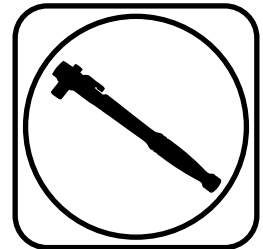

1965-1979 Ford F100 HQ Series Rear CoilOvers

Installation Instructions

Table of contents

Page 61..... Included Components

Page 62..... Assembly and CoilSpring Adjustment

Page 63..... CoilSpring and Shock Adjustment

CoilOver Dimensions:

Center of bearing to Center of bearing:

Compressed: 11.23"

Ride Height: 14.50"

Extended: 16.43"

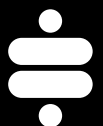



Major ComponentsIn the box

Item #	Part #	Description	QTY
1	982-10-805	5.2" Stroke HQ Series Shock	2
2	815-05-022-KIT	1.7" Shock Eyelet	2
3	803-00-109(kit)	Upper CoilSpring Retaining Plate (803-00-109 kit)	
4	59120200	Coilspring 12" 200lb	2
5	70010828	Delrin Spring Washer	4
6	803-00-109(kit)	Lower Spring Adjuster Nut (803-00-109 kit)	2
7	803-00-109(kit)	Adjuster Nut Locking Screw (803-00-109 kit)	2
8	803-00-109(kit)	Retaining Ring (803-00-109 kit)	2
	90001994	5/8" ID Bearing (installed in shock and eyelet)	4
	90001995	Bearing Snap Ring (installed in shock and eyelet)	8

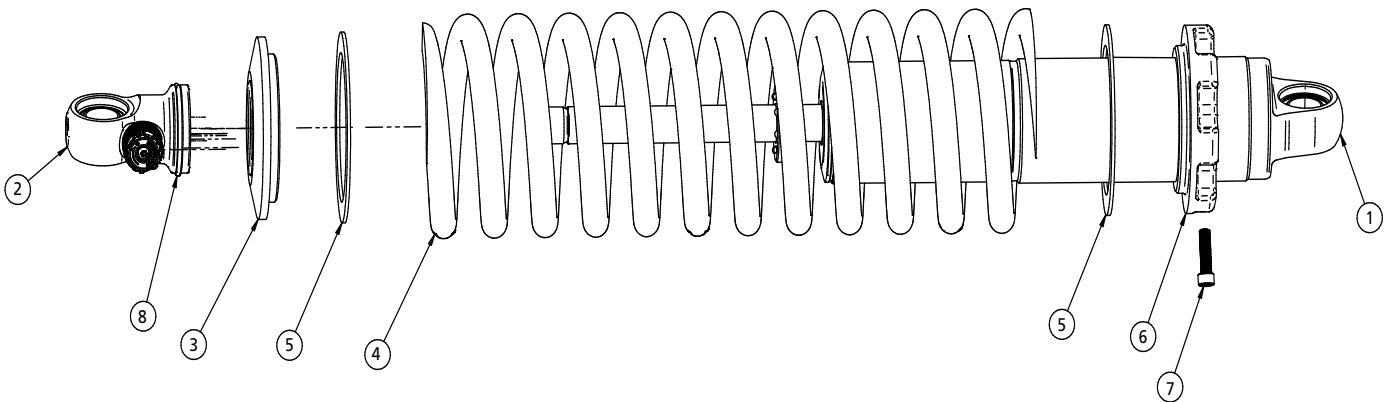



CoilOver Assembly...



1

First, using the supplied lower adjuster nut (803-00-199) thread the nut onto the shock from the bottom side as seen in figure 1. Remove the plastic pellet that is in the split of the adjuster nut.

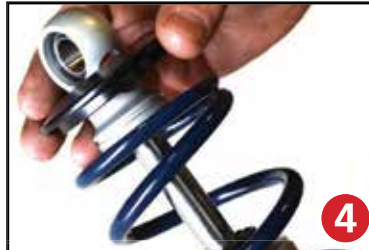

4

Once the knob is removed slide a Delrin washer over the eyelet. Next, slide the upper spring mount (803-00-199) over eyelet as seen in figure 4.



2

Next, install a delrin washer then coil spring over the top of the shock as seen in figure 2.



5

Install upper spring mount retainer clip (803-00-199) into the groove on the upper eyelet as seen in figure 5. Then, reinstall adjuster to complete assembly.



3

Before the upper spring mount can be installed screw the adjuster knob on the upper eye mount to the firmest setting (clockwise) as seen in figure 3. Then remove the Knob by holding it while removing the center screw.

Install the locking screw in the adjuster nut before setting spring preload, but DO NOT tighten until the spring preload has been set.

NOTE: Remember to adjust the shock valving before driving, the shock is currently set to full stiff.

CoilSpring Adjustment

6. Preload the springs of the CoilOver 1" to start. **Steps 6a - 6e** will assist you with preloading the coil spring. You may need to adjust the amount of preload in the spring, but this will be determined after the vehicle has been sat on the ground.

6a. Verify the adjuster nut locking screw is installed in the adjuster nut, but not tight.

6b. Thread the spring adjuster nut up the shock body until it is snug against the spring. You should NOT be able to move the spring up and down on the shock (0 preload). Verify the upper coil spring cap is seated correctly on the upper shock stud.

6c. Measure from the bottom of the adjuster nut to the flat of the shock. You may want to write the measurement down.

6d. Using a spanner wrench, thread the adjuster up the shock an additional 1" (from the measurement you took in step 2) to preload the spring.

6e. Lock the adjusting nut in place by tightening the adjuster nut locking screw.

7. Reinstall the rear wheels and tires and set the rear of the vehicle back on the ground.

8. After entire weight of vehicle is on the wheels, jounce the suspension and roll the car forward and backward to alleviate suspension bind. **THIS IS NECESSARY BEFORE MEASURING RIDE HEIGHT.**



CoilSpring Adjustment

9. If you determine you need to adjust the ride height of the rear suspension after getting the vehicle on the ground, **Steps 9a - 9e** will assist you in adjusting the ride height.
 - 9a. Raise the vehicle and support it by the frame, allowing the suspension to hang freely. You do NOT need to remove the rear wheels.
 - 9b. Loosen the locking screw in the adjuster nut, but do not remove the locking screw.
 - 9c. Measure from the bottom of the adjuster nut to the flat of the shock. You may want to write the measurement down.
 - 9d. Using a spanner wrench, thread the adjuster up or down the shock to obtain the correct ride height. One complete revolution of the adjuster nut is approximately 1/16" at the wheel. Threading the adjuster nut up the shock will raise the ride height, threading it down will lower the ride height.
 - 9e. Lock the adjusting nut in place by tightening the adjuster nut locking screw.
10. After entire weight of vehicle is on the wheels, jounce the suspension and roll the vehicle forward and backward to alleviate suspension bind. **THIS IS NECESSARY BEFORE MEASURING RIDE HEIGHT.**
11. Recheck your ride height. If you need to readjust, repeat **Steps 9-10.**

Shock Adjustment 101- Single Adjustable

Rebound Adjustment:

How to adjust your new shocks.

The rebound adjustment knob is located on the top of the shock absorber, protruding from the eyelet. You must begin at the ZERO setting, then set the shock to a medium setting of 12.



-Begin with the shocks adjusted to the ZERO rebound position (full stiff). Do this by rotating the rebound adjuster knob clockwise until it stops.

-Now turn the rebound adjuster knob counter clockwise 12 clicks. This sets the shock at 12. Settings 21-24 are typically too soft for street use.

Take the vehicle for a test drive.



-If you are satisfied with the ride quality, do not do anything. You are set!

-If the ride quality is too soft, increase the damping effect by rotating the rebound knob clockwise 3 clicks.

Take the vehicle for another test drive.



-If the vehicle is too soft, increase the damping effect by rotating the rebound knob clockwise 3 additional clicks.

-If the vehicle is too stiff, rotate the rebound adjustment knob counter clockwise 2 clicks and you are set!

Take the vehicle for another test drive and repeat the above steps until the desired ride quality is achieved.