



Part # 13130110/13130115 - 2019-2023 Ram 1500 2WD/4WD Lowering Kit with HQ CoilOvers

Front Components

13133699 Front Upper Control Arms
13133110/13133115 Front CoilOver Kit

Rear Components

13139511 Rear Lowering Kit
13136110 Rear CoilOver Kit

Recommended Tools

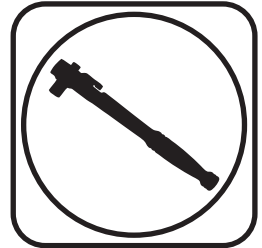

2019-2023 Ram 1500 2WD/4WD Lowering Kit

Installation Instructions

Table of contents

Page 2-10.....Front Installation Instructions
Page 10-29..... Rear Installation Instructions
Page 30..... CoilSpring Adjustment & Alignment
Page 31..... Torque Specifications & Shock Adjustment





Major ComponentsIn the box

Item #	Part #	Description	QTY
1	90003553	Upper CoilOver Mount	2
Coil Over Shock Assembly			
2	986-10-124	5.2" Stroke HQ Series Shock	2
3	90002398	Lower Shock Ring	2
4	90002397	Lower Shock Puck	2
5	90003554	Lower Shock Mount	2
6	815-05-022-KIT	1.7" Shock Eyelet Assembly	2
7	90001994	5/8" ID Shock Bearing	2
8	90001995	Shock Bearing Snap Ring	4
	99501031	1/2" -13 x 3/4" Button Head Bolt	2
	99503006	1/2" SAE Flat Washer	2
9	038-01-006-A	CoilSpring Plate Retaining Ring	2
10	90002070	Dropped CoilSpring Cap	2
11	234-15-200	Lower Spring Adjuster Nut	2
12	99050001	Adjuster Nut Locking Screw	2
13	70010828	Delrin Spring Washer	4
14	59100750 (2WD) or 59100850 (4WD)	CoilSpring 10" (2WD) 750lb - 2WD or CoilSpring 10" (4WD) 850lb - 4WD	2 or 2
15	90002043	.500 x .365 Shock Bearing Spacers	4
	85000000	Spanner Wrench	1

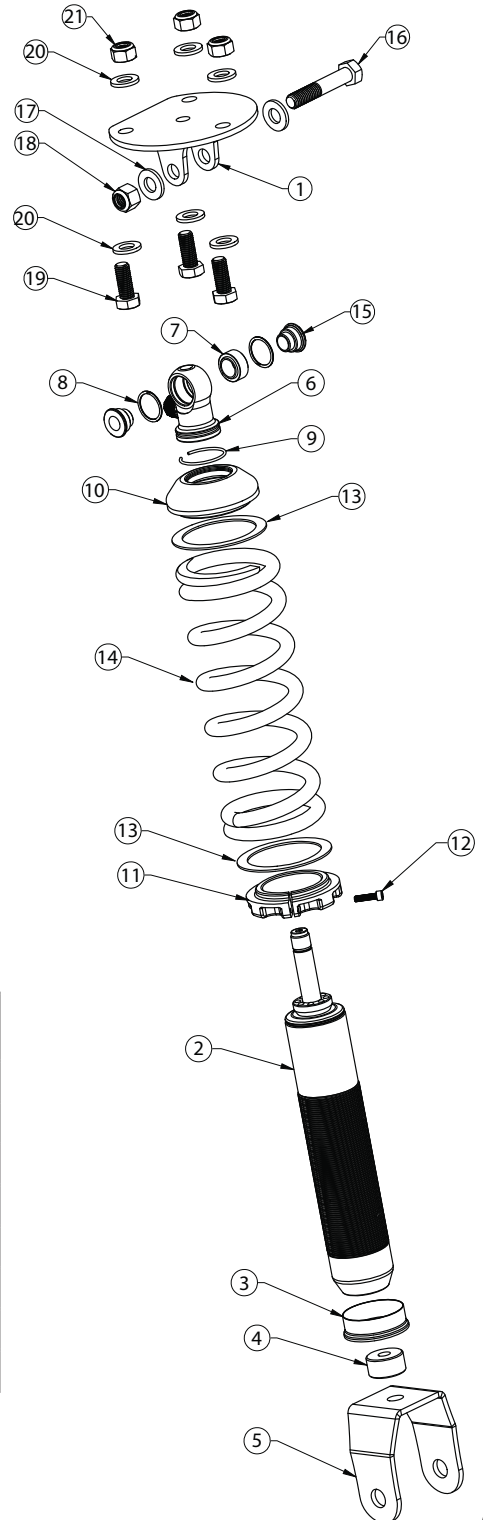

HARDWARE LIST - Kit # 99010240

Item #	Part #	Description	QTY
SHOCK TO SHOCK MOUNT			
15	99501050	1/2"-13 x 2 1/2" Hex Bolt	2
16	99503014	1/2" SAE Flat Washer	4
17	99501064	1/2"-13 Nylok Nut	2
LOWER MOUNT TO CONTROL ARM			
18	99121005	M12-1.75 X 30mm Hex Bolt	6
19	99123002	M12 Flat Washer	12
20	99122009	M12-1.75 Nylok Nut	6



Major ComponentsIn the box

Item #	Part #	Description	QTY
1	90003551	Upper Control Arm - Driver (<i>shown</i>)	1
	90003552	Upper Control Arm - Passenger	1
2	70016702	Upper Control Arm Bushings	4
3	70016703	Upper Control Arm Ball Joint	2
4	70015619	Upper Ball Joint Dust Cap	2
5	99143001	M14 Flat Washer - Ball Joint to Spindle	4

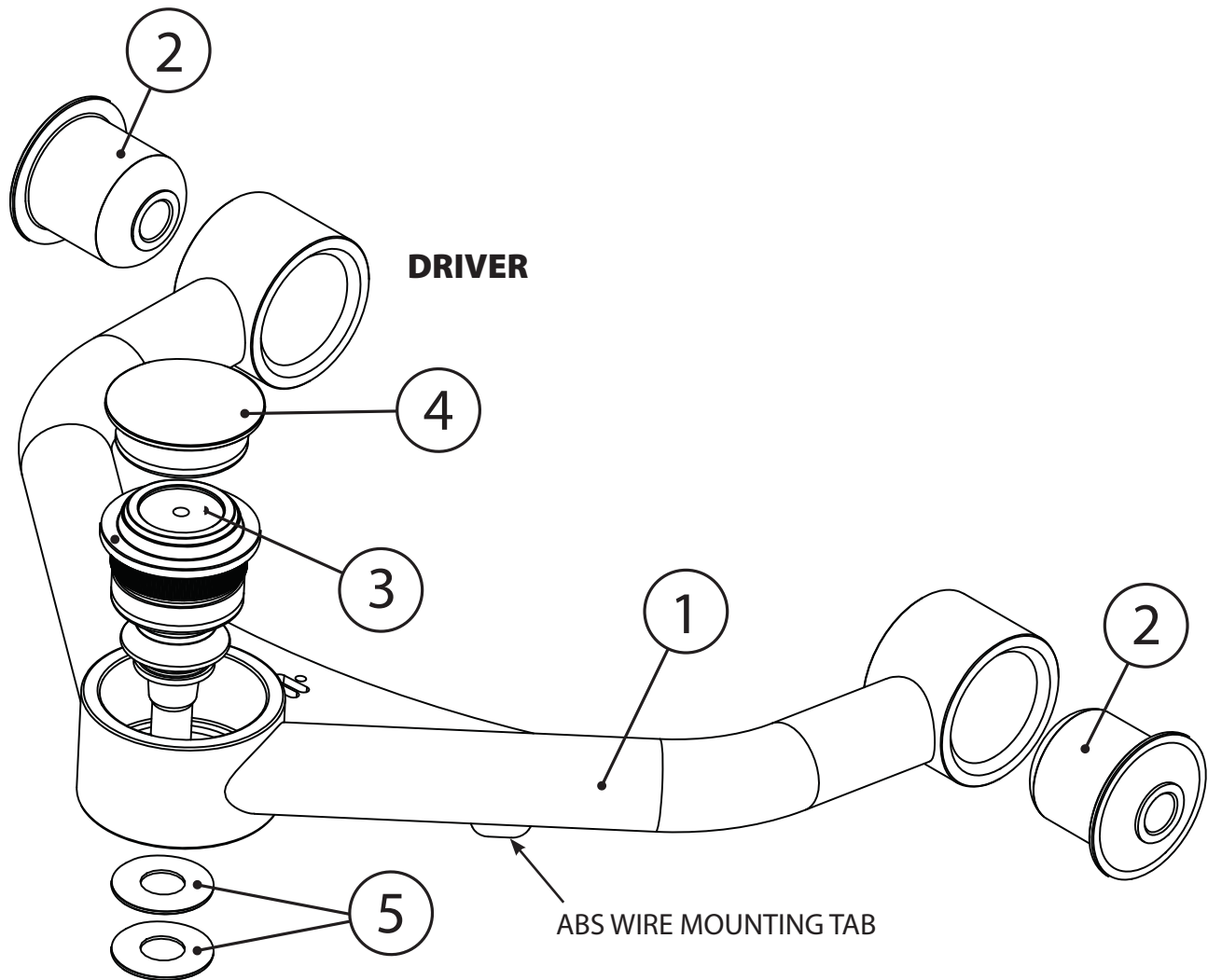



Disassembly

This Kit is Designed to replace the factory Control Arms, Shocks, and Springs.

The front OEM Shock and Spring assemblies will need to be removed from the front of the truck. **DO NOT DISASSEMBLE THE SHOCK/SPRING ASSEMBLY, THE COILSPRING IS UNDER COMPRESSION AND COULD CAUSE BODILY INJURY!**

1. Raise the vehicle and support it by the frame, allowing the suspension to hang freely. Remove the wheels.
2. Remove the shock/spring assembly from both sides of the truck. **DO NOT DISASSEMBLE THE SHOCK/SPRING ASSEMBLY, THE COILSPRING IS UNDER COMPRESSION AND COULD CAUSE BODILY INJURY!**



3. Disconnect the sway bar from the control arms. This allows the lower control arm to move easier during the CoilOver installation.



4. Unbolt the brake line from the frame, but retain the OEM hardware. This allows the lower control arm to move easier during the CoilOver installation.



5. Detach the ABS wire from the upper control arm.



Disassembly



6. The upper control arm will need to be disconnected from the steering knuckle. Remove the OEM upper control arm. Retain the hardware to install the new upper control arm.

Getting Started.....

7. The CoilOvers need to be assembled before putting the shocks in the mounts. Assemble the shocks and springs using the instructions below.

CoilOver Assembly...



First, using the supplied lower adjuster nut (234-15-200) thread the nut onto the shock from the top of shock as seen in figure A. Remove the plastic pellet that is in the split of the adjuster nut.



Once the knob is removed slide a Delrin washer over the eyelet. Next, slide the upper spring mount (9000-2070) over eyelet as seen in figure D.



Next, install a delrin washer then coil spring over the top of the shock as seen in figure B.



Install upper spring mount retainer clip (038-01-006-A) into the groove on the upper eyelet as seen in figure E. Then, reinstall adjuster to complete assembly.



Before the upper spring mount can be installed screw the adjuster knob on the upper eye mount to the firmest setting (clockwise) as seen in figure C. Then remove the Knob by holding it while removing the center screw.

Install the locking screw in the adjuster nut before setting spring preload, but DO NOT tighten until the spring preload has been set.

NOTE: Remember to adjust the shock valving before driving, the shock is currently set to full stiff.



CoilOver Installation

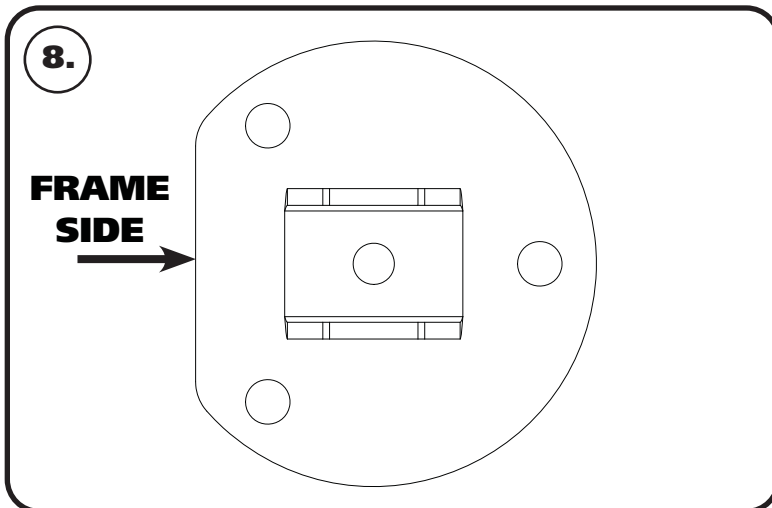

8. Image 8 illustrates the upper coil over mount. The flat side of the mount will need to be positioned to the frame.



9. Position the upper coil over mount in the OEM location with the flat side positioned to the frame. Install a M12 flat washer on each of (3) M12-1.75 x 30mm hex bolts. With the mounting holes aligned, insert a bolt/washer in each hole. Install a M12 flat washer & M12-1.75 nylok nut on each bolt. Torque the bolts to 69 ft-lbs.



10. Install the 1/2" I.D. bearing spacers into the bearing in the shock eyelet. These spacers have a through hole that is 1/2" diameter. The small diameter of the spacers will insert into the shock bearing.



CoilOver Installation



11. Insert the shock eyelet into the upper mount. **Install each CoilOver in the upper mount with the Adjusting Knob facing the wheel of the truck.** Line up the shock bearing/spacers hole with the mounting holes of the upper mount.



12. Install a 1/2" flat washer on a 1/2"-13 x 2 1/2" bolt. Insert a bolt/washer through the mount/shock. Install a 1/2" flat washer and 1/2"-13 nylok nut on the threads of the bolt that are sticking through the mount. Torque the upper mounting hardware to 75 ftlbs.



13. Use a jack under the lower control arm to raise the control arm. Align the OEM shock mount with the lower shock mount of the coil over.



CoilOver Installation



14. Install the OEM lower shock bolt. We recommend installing the bolt with the threads to the rear of the truck. Install the OEM nut on the threads of the bolt. Torque the shock bolt to 125 ft-lbs.

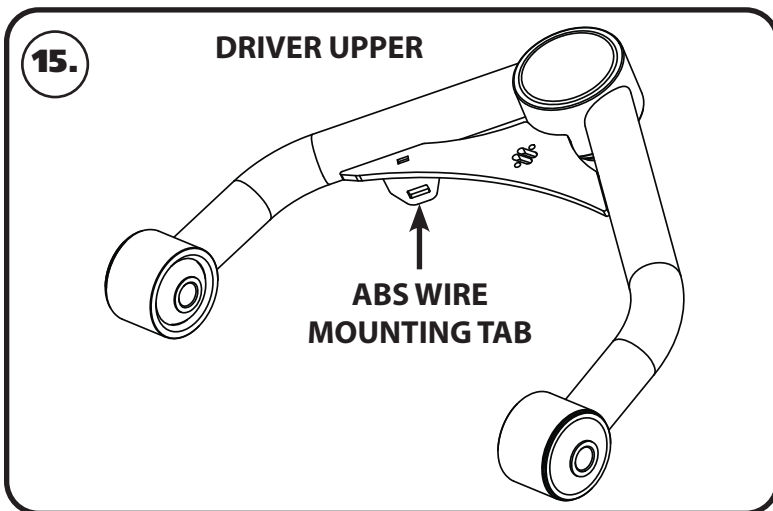

15. The upper control arms are side specific. The driver control arm is shown in **Image 15**. The ABS wire tab is to the rear of the truck.



16. Install the Ridetech upper control arms using the OEM hardware. The control arms are mounted in the OEM mounts with the ABS wire tab to the rear of the truck. The control arm mounting bolts will need to be tightened after the truck is sitting on the ground.



CoilOver Installation



17. Insert the ball joint stud into the spindle. Install (2) M14 flat washers on the ball joint stud. Next, install the ball joint nut and torque to 50 ft-lbs. Tighten the nut until a slot in the nut aligns with the hole in the ball joint pin. NEVER LOOSEN THE NUT TO ALIGN THE HOLE!



18. Install the supplied cotter pin. Bend the tabs of the cotter pin.



19. Insert the OEM ABS clip into the tab of the control arm.



20. Reattach the sway bar linkage. The lower sway bar linkage nut is torqued to 75 ft-lbs.



CoilSpring Adjustment

21.

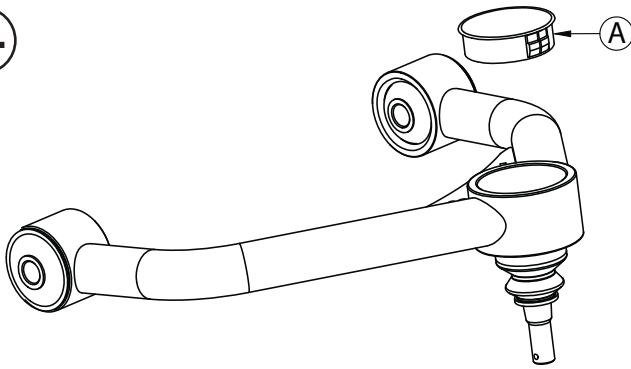

21. Insert the grease zerks in the ball joints. Grease the ball joints and install the supplied caps(A). These caps will help keep debris out of the control arms.

22. Repeat steps 3-21 on the other side of the truck.

Rear Suspension ComponentsIn the box

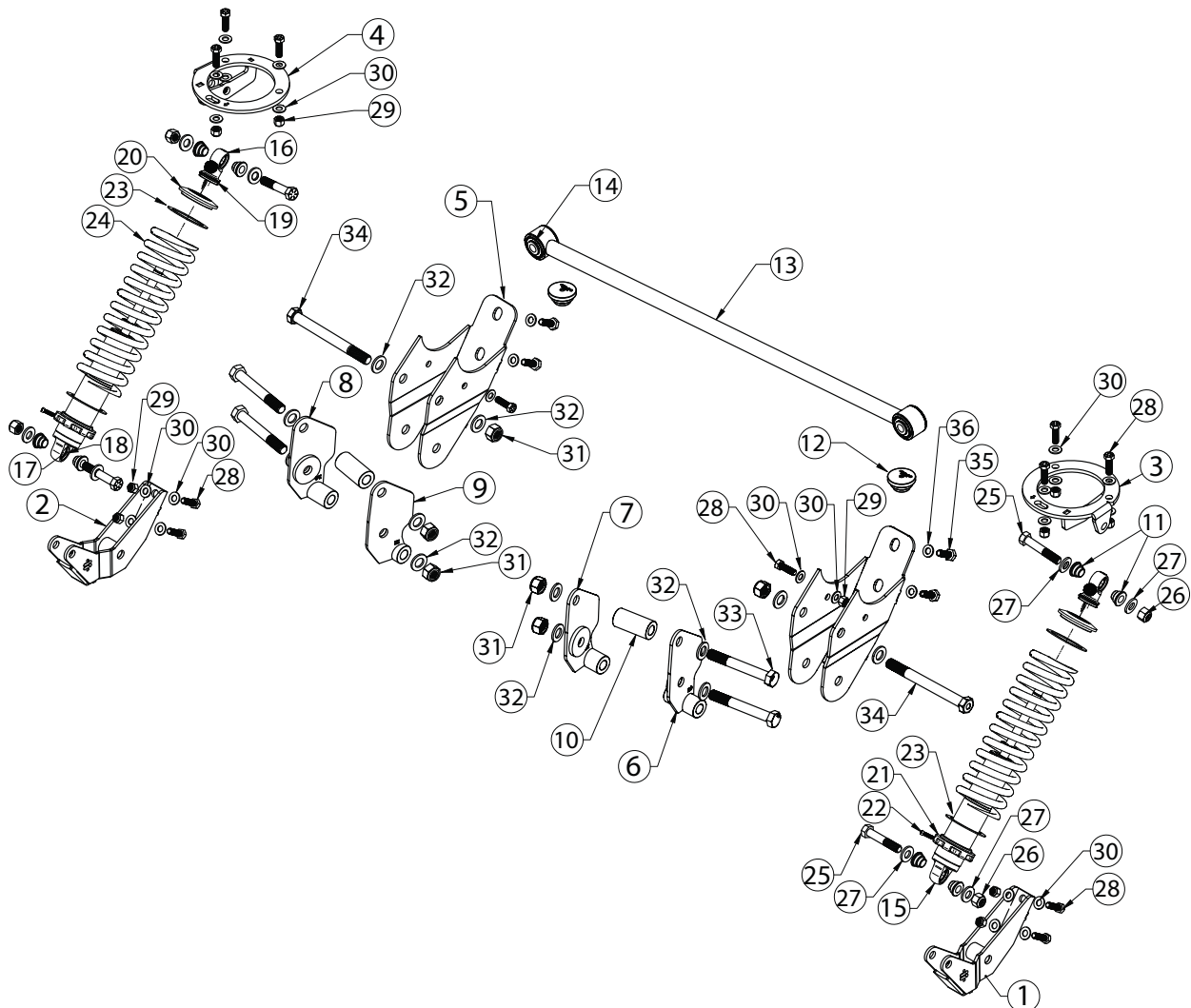



Major ComponentsIn the box

Item #	Part #	Description	QTY
1	90003555	Lower Shock Mount - Driver	1
2	90003584	Lower Shock Mount - Passenger	1
3	90003556	Upper Shock Mount - Driver	1
4	90003583	Upper Shock Mount - Passenger	1
5	90003557	Lower Bar Relocation Bracket	2
6	90003558	Upper Bar Relocation Bracket - Driver Outer	1
7	90003559	Upper Bar Relocation Bracket - Driver Inner	1
8	90003560	Upper Bar Relocation Bracket - Passenger Outer	1
9	90003561	Upper Bar Relocation Bracket - Passenger Inner	1
10	90003562	Spacer Sleeve - 1.25" OD x .65" ID x 2.625" Long	2
11	90002043	Shock Bearing Spacers - .500" ID x .365" Long	8
12	70015643	Bumpstops	2
13	90003563	Track/Panhard Bar	1
14	70016734	Track/Panhard Bushings - installed in panhard bar	2
15	982-10-806	6.3" Stroke HQ Series Shock	2
16	815-05-022-KIT	1.7" Shock Eyelet Assembly	2
17	90001994	5/8" ID Bearing (installed in shock and eyelet)	4
18	90001995	Bearing Snap Ring (installed in shock and eyelet)	8
19	038-01-006-A	Upper Coil Spring Cap Retaining Ring	2
20	234-14-500	Upper Coil Spring Cap	2
21	234-15-200	Lower Spring Adjuster Nut	2
22	99050001	Adjuster Nut Locking Screw	2
23	70010828	Delrin Spring Washer	4
24	59140350	Coilspring 14" 350lb	2
END LINK ASSEMBLY			
	90003842	10mm 90 Degree End link	4
	90003506	End link Spacer	2
	99115012	M10-1.5 130mm Threaded Rod	2
	90002275	Copper Crush Washer	4



Hardware Kit# 99010241

Item #	Part #	Description	QTY	Item #	Part #	Description	QTY
SHOCK TO LOWER SHOCK MOUNT				LOWER BAR MOUNT TO AXLE			
25	99501064	1/2-13 X 2 3/4" Hex Bolt	2	28	99371005	3/8"-16 X 1 1/4" Hex Bolt	2
26	99502009	1/2"-13 Nylok Nut	2	29	99372001	3/8"-16 Nylok Nut	2
27	99503014	1/2" SAE Flat Washer	4	30	99373002	3/8" SAE Flat Washer	4
SHOCK TO UPPER SHOCK MOUNT				31	99162000	M16-2.0 Nylok Nut	2
25	99501064	1/2"-13 X 2 3/4" Hex Bolt	2	32	99163003	M16 Flat Washer	4
26	99502009	1/2"-13 Nylok Nut	2	34	99161000	M16-2.0 x 170mm Hex Bolt	2
27	99503014	1/2" SAE Flat Washer	2	35	99111002	M10-1.5 x 30mm Hex Bolt	4
LOWER SHOCK MOUNT TO AXLE				36	99113002	M10 Flat Washer	4
28	99371005	3/8"-16 X 1 1/4" Hex Bolt	4		90002263	Red Loctite	1
29	99372001	3/8"-16 Nylok Nut	4	BUMPSTOP TO FRAME			
30	99373002	3/8" SAE Flat Washer	8		99371034	3/8"-16 x 1" SHCS	2
UPPER SHOCK MOUNT TO FRAME					99372002	3/8"-16 Nylok Nut	2
28	99371005	3/8"-16 X 1 1/4" Hex Bolt	6		99373002	3/8"-16 SAE Flat Washer	2
29	99372001	3/8"-16 Nylok Nut	6	SWAY BAR END LINK			
30	99373002	3/8" SAE Flat Washer	12		99113002	M10 Flat Washer	6
UPPER BAR MOUNT TO AXLE					99112002	M10-1.5 Nylok Nut	2
31	99162000	M16-2.0 Nylok Nut	4		90002263	Red Loctite	1
32	99163003	M16 Flat Washer	8				
33	99161001	M16-2.0 x 120mm Hex Bolt	4				

Getting Started.....

1. Raise the vehicle to a safe and comfortable working height and support it by the frame. You will need to be able to move the rear differential up and down. Use a jack under the rear axle to raise and lower it during the install.
2. Jack up the rear end slightly to remove the tension from the rear shocks. Remove the shock absorbers.
3. Lower the jack to relieve the tension on the rear springs, but keep the jack touching the rear axle. You will need to keep the rear end supported during the install.

DO NOT strain the brake lines.

If installing the Ridetech 4 link bars, install them in conjunction with this lowering kit.



CoilOver Assembled

4. The CoilOvers need to be assembled before putting the shocks in the mounts. Assemble the shocks and springs using the instructions below.

CoilOver Assembly...



First, using the supplied lower adjuster nut (803-00-199) thread the nut onto the shock from the bottom side as seen in figure A. Remove the plastic pellet that is in the split of the adjuster nut.



Next, install a delrin washer then coil spring over the top of the shock as seen in figure B.



Before the upper spring mount can be installed screw the adjuster knob on the upper eye mount to the firmest setting (clockwise) as seen in figure C. Then remove the Knob by holding it while removing the center screw.



Once the knob is removed slide a Delrin washer over the eyelet. Next, slide the upper spring mount (803-00-199) over eyelet as seen in figure D.



Install upper spring mount retainer clip (803-00-199) into the groove on the upper eyelet as seen in figure E. Then, reinstall adjuster to complete assembly.

Install the locking screw in the adjuster nut before setting spring preload, but DO NOT tighten until the spring preload has been set. Set the spring preload after the CoilOver has been installed.

NOTE: Remember to adjust the shock valving before driving, the shock is currently set to full stiff.

Disassembly



5. Remove the rear wheel liners. Retain the liners and the hardware to reinstall them after the lowering kit has been installed.



Disassembly



6. Remove the sway bar linkage. It will be replaced with new linkage.



7. Remove the rear sway bar. It will be reinstalled after the lowering kit is installed.



8. Lower the axle as far as the OEM bar bushing will allow it to go, but make sure the axle is still supported by the jack. Remove the control arm control arm bolts at the axle.



Disassembly & Axle Modifications



9. Remove the rear coil springs. You may have to push down on the end of the axle to get the coil spring out of the mount.



10. The OEM bump stop mount will need to be removed. The bump stop snaps into the OEM mount. Push on the side of it to get it to pop out of the mount.



11. The rear surface of the control arm/sway bar mount needs to be flat. The lower edge is bent, but will need to be flattened. Use a straight edge to see how much it needs to be flattened.



Axle Modifications



12. Use a hammer to flatten the bottom of the control arm/sway bar mount.



13. You can check for flatness with a straight edge on the mount.



14. The front of the OEM upper bar mounts will need to be cutoff. Images 14 & 15 show the mount marked and after it has been cut. Mark a straight line from where the end radius stops to just where the weld on the axle tube stops



Axle Modifications & Bump Stop Installation



15. Image 15 illustrates the cut mount and the piece that was cut off.



16. The bump stop mounting ring will need to be cutoff the truck. Just the ring needs cutoff, leaving the mount the ring is welded to. It can be cut off with a die grinder and cutoff wheel by cutting the welds. Grind the surface smooth and paint it.



17. Bolt the supplied bump stops to the flat surface of the OEM mount. It is attached using (1) 3/8"-16 x 1" socket head cap screw, (1) 3/8" SAE flat washer, & (1) 3/8"-16 nylok nut. Torque to 35 in-lbs.



Upper Shock Mount Installation

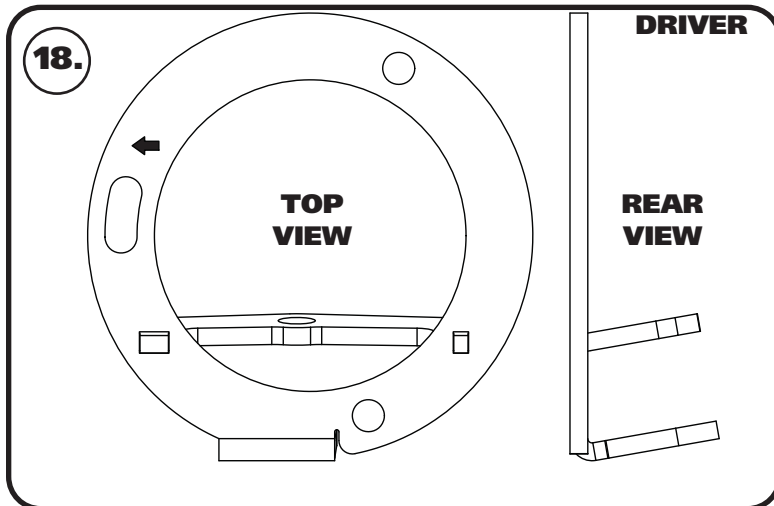

18. The upper shock mounts are side specific. **Image 18** shows the Driver side upper mount. The arrow that is cut in the bracket will point to the front of the truck with the coilover moved out away from the frame.



19. Align the upper shock mount with the holes in the OEM coil spring mount. Again, the Arrow will point to the front of the truck with the shock mount out away from the frame.



20. Install a 3/8" flat washer on each of (3) 3/8"-16 x 1 1/4" bolts. Hold the bracket in position and put the bolts/washer through the mounting holes. Install a 3/8" flat washer & 3/8"-16 nylok nut on each of the bolts. Torque hardware to 35 ft-lbs.



Lower Shock Mount Installation

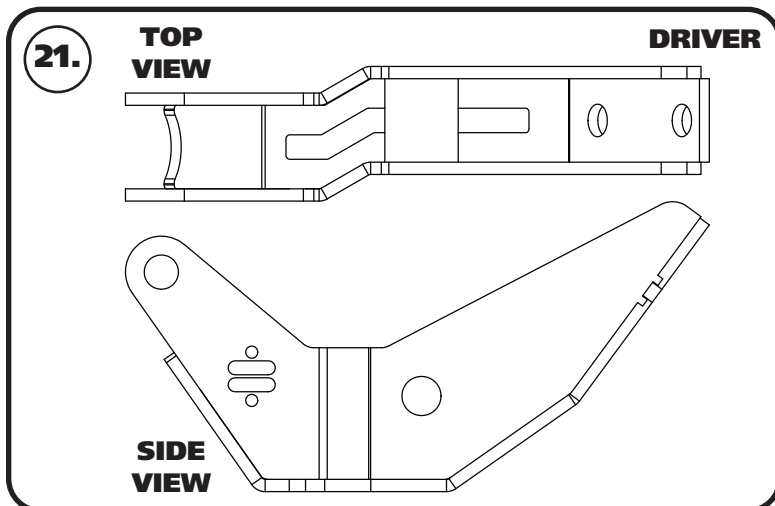

21. The lower shock mount offsets the bottom of the shock to the wheel for better spring clearance. The Driver lower shock mount is shown in **Image 21**.



22. The lower shock mount will be positioned in the OEM lower shock mount. The large mounting hole will align with OEM shock mounting hole. Align the holes and insert the OEM shock bolt in the aligned holes.

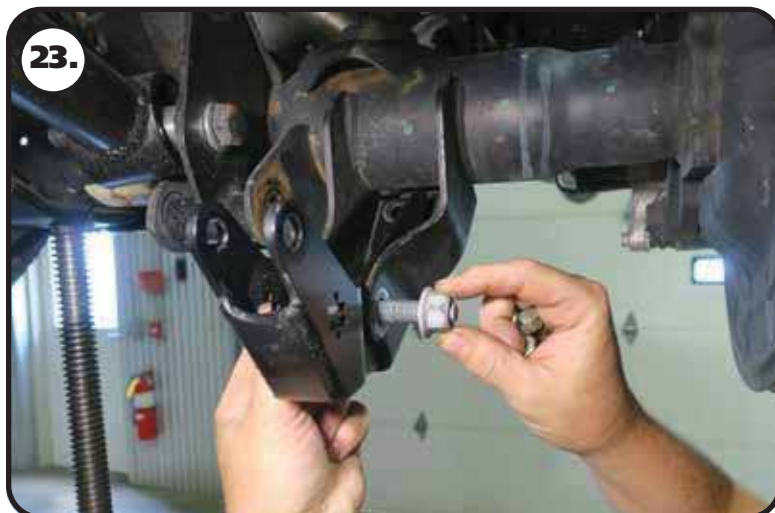

23. Install the OEM nut on the OEM bolt, but do not tighten until the (2) rear bolts are installed.



Lower Shock Mount Installation



24. Install a 3/8" flat washer on each of (2) 3/8"-16 x 1 1/4" hex bolt. Insert the bolts/washers in from the bottom. Install a 3/8" flat washer & 3/8"-16 nylok nut on each bolt. Torque the 3/8" hardware to 35 ft-lbs.



25. Torque the OEM shock bolt to 100 ft-lbs.



If you are installing the Ridetech 4-Link bars, install them in conjunction with the 4-link bar relocation brackets.



26. The lower bar bracket is the same for driver and passenger. The lower bar will need to be inserted into the bracket before putting it in place. The bolt must be installed from the outside with the threads pointing in. This reuses the OEM lower bolt. The bar mounting bolt needs to be left loose.



Control Arm Relocation Bracket Installation



27. The lower relocation bracket will slip over the OEM lower bar bracket.



28. Align the OEM lower bar mounting hole with the hole in the new mount. Insert a M16-2.0 x 170mm bolt through the hole to keep it aligned. Do not put a nut on the bolt as it will be removed later.



29. Install a M10 flat washer on a M10-1.5 x 30mm bolt. Install the bolt/washer in one of the rear holes. Snug the bolt down, but do not torque since it will be removed later.



Control Arm Relocation Bracket Installation



30. There is a hole on the inside of the bracket that will need to be used as a template to drill a 3/8" hole in the OEM mount. Drill the hole with a 3/8" drill bit. Install a 3/8" flat washer on a 3/8"-16 x 1 1/4" bolt. Insert the bolt/washer in the drilled hole. Install a 3/8" flat washer & 3/8"-16 nylok nut on the bolt. Torque the hardware to 35 ft-lbs.



31. Remove the M16-2.0 x 170mm bolt from the lower mount.

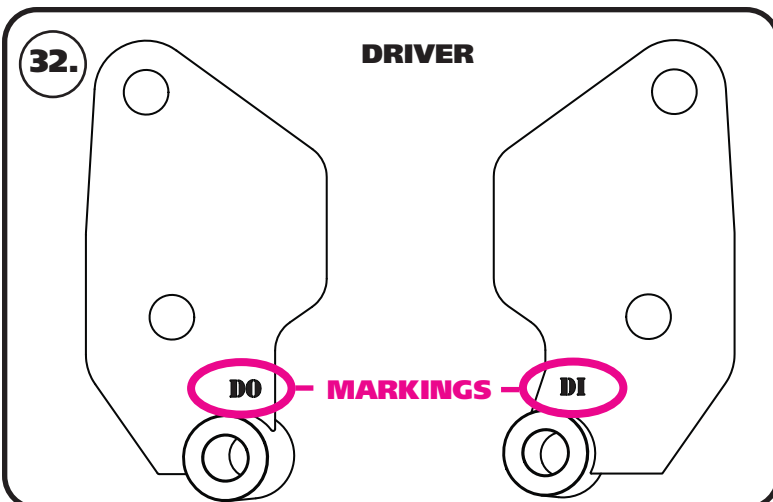

32. This kit requires the upper control arm to be relocated to correct the geometry for the new ride. The kit includes brackets for relocating the upper control arms. The control arm brackets are marked for vehicle side and location. **Image 32** illustrates the driver side relocation brackets. They are marked DO for Driver Outer and DI for Driver Inner. The flat side of the bracket is positioned to the front of the truck.



Control Arm Relocation Bracket Installation

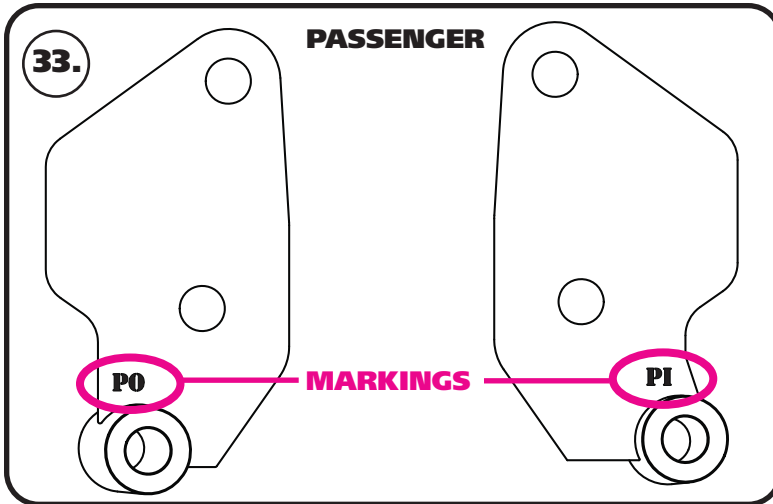

33. Image 33 illustrates the passenger side relocation brackets. They are marked PO for Passenger Outer and PI for Passenger Inner. The flat side of the bracket is positioned to the front of the truck.



34. The upper brackets need to be installed to relocate the upper bars. Each bracket will be positioned to the outside of the OEM upper bar mount. Start by aligning the sleeve on the Inner bracket with the OEM lower bar mounting hole. Install a M16 flat washer on a M16-2.0 x 170mm bolt. Insert the bolt through the sleeve and through the OEM lower bar mounting hole. Make sure the bolt is not sticking through the OEM mount. If it is sticking out, the outer bracket can not be inserted.



35. Align the sleeve of the Outer bracket with the bolt holes of the OEM lower bar mount. Push the M16-2.0 x 170mm bolt through the bracket.



Control Arm Relocation Bracket Installation



36. Install a M16 flat washer and M16-2.0 nylok nut on the threads of the bolt. Do not tighten this hardware at this time.



37. Install the 2 5/8" long spacers between the OEM upper bar mounts. Align the hole with the holes of the upper bar mounts. The top hole of the upper bar relocation brackets need to be aligned too.



38. Install a M16 flat washer on a M16-2.0 x 120mm bolt. Insert the bolt through the aligned holes. Install a M16 flat washer & M16-2.0 nylok nut on the threads of the bolt. Do not tighten hardware at this time.



Control Arm Relocation Bracket & Panhard Bar Installation



39.

39. Align the end of the upper bar with the center holes of the relocation brackets. Install a M16 flat washer on a M16-2.0 x 120mm bolt. Insert the bolt through the aligned holes.

If installing the Ridetech 4-Link bars, this bolt will be replaced with a 5/8"-18 x 5" bolt and 5/8" flat washer from the 4-link bar kit.



40.

40. Align the end of the upper bar with the center holes of the relocation brackets. Install a M16 flat washer on a M16-2.0 x 120mm bolt. Insert the bolt through the aligned holes.

If installing the Ridetech 4-Link bars, this hardware will be replaced by 5/8" hardware from the 4-link bar kit.



41.

41. Remove the OEM panhard bar. Retain the OEM hardware for installation of the new panhard bar.



Panhard Bar & CoilOver Installation



42. Both ends of the new panhard bar are the same. Insert one end of the panhard in the OEM frame mount. Insert the OEM panhard hardware and install the nut. Do not tighten the hardware at this time.



43. Insert the other end of the panhard in the mount on the axle. Insert the OEM panhard hardware and install the nut. Do not tighten the hardware at this time. The hardware will be torqued after the truck is on the ground.



44. Insert the shock bearing spacers into the bearings of the eyelet of the coilover. The small diameter of the spacers will get inserted into the bearing.



CoilOver Installation



45. Insert the eyelet of the coilover in the previously installed upper shock mount. Line up the through hole of the bearing/spacers with the mounting holes of the upper shock mount.



46. Install a 1/2" flat washer on a 1/2"-13 x 2 3/4" bolt. Insert the bolt/washer into the upper mount/shock. Install a 1/2" flat washer and 1/2"-13 nylok nut and Torque to 75 ftlbs.



47. Insert the shock bearing spacers into the bearings of the bearings of the coilover. The small diameter of the spacers will get inserted into the bearing.



CoilOver & Sway Bar Installation



48. Insert the body of the coilover in the previously installed lower shock mount. Line up the through hole of the bearing/spacers with the mounting holes of the lower shock mount.



49. Install a 1/2" flat washer on a 1/2"-13 x 2 3/4" bolt. Insert the bolt/washer into the lower mount/shock. Install a 1/2" flat washer and 1/2"-13 nylok nut and Torque to 75 ftlbs.



50. Install a M10 flat washer on each of (4) M10-1.5 x 30mm hex bolts. Hold the OEM sway bar in position and attach it using the (4) bolts/washer in the OEM mounting holes. Do not tighten the hardware until the sway bar linkage is installed.



Sway Bar Installation

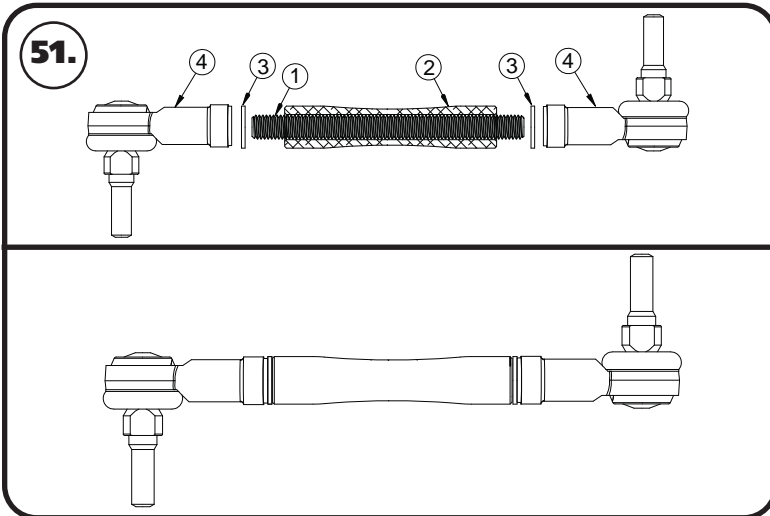

51. The sway bar linkage will need to be assembled. Insert the M10-1.5 x 130mm threaded stud in the 3.68" spacer. Put a copper crush washer on each end of the threaded stud. Put red loctite on the threads of each end of the stud. Thread a 90 degree end on each end and tighten the ends. The studs need to be pointing away from each other after the linkage is tight. See **Image 51**.



52. Install a M10 flat washer on the threaded stud of sway bar linkage. Apply red loctite to the threads of the end link and thread it into the OEM sway bar linkage mount.



53. Install a M10 flat washer on the threaded stud of the lower linkage. Insert the threaded stud in the OEM sway bar. Install a M10 flat washer & on the threaded stud sticking through the sway bar. Torque the sway bar mounting and end link hardware to 37 ft-lbs.



Coil Spring Preload and Final Tightening

54. Preload the springs of the CoilOver 3/4" to start. **Steps 54a - 54e** will assist you with preloading the coil spring. You may need to adjust the amount of preload in the spring, but this will be determined after the truck has been sat on the ground.

54a. Verify the adjuster nut locking screw is installed in the adjuster nut, but not tight.

54b. Screw the spring adjuster nut up the shock body until it is snug against the spring. You should NOT be able to move the spring up and down on the shock (0 preload). Verify the dropped upper coil spring cap is seated correctly on the upper shock eyelet.

54c. Measure from the bottom of the adjuster nut to the flat of the shock. You may want to write the measurement down.

54d. Using a spanner wrench, thread the adjuster up the shock an additional 3/4" (from the measurement you took in step 2) to preload the spring.

54e. Lock the adjusting nut in place by tightening the adjuster nut locking screw.

55. After entire weight of truck is on the wheels, jounce the suspension and roll the truck forward and backward to alleviate suspension bind. **THIS IS NECESSARY BEFORE TIGHTENING THE CONTROL ARM AND TRACK BAR HARDWARE.**

56. Torque front upper control arm hardware to 130 ft-lbs.

57. Torque the rear control arm hardware to 195 ft-lbs.

58. Torque the panhard/track bar hardware to 95 ft-lbs.

59. DOUBLE CHECK THE HARDWARE TO MAKE SURE IT IS TIGHT.

60. If you determine you need to adjust the ride height of the front suspension after getting the truck on the ground, **Steps 60a - 60e** will assist you in adjusting the ride height.

60a. Raise the vehicle and support it by the frame, allowing the suspension to hang freely. You do NOT need to remove the wheels

60b. Loosen the locking screw in the adjuster nut, but do not remove the locking screw.

60c. Measure from the bottom of the adjuster nut to the flat of the shock. You may want to write the measurement down.

60d. Using a spanner wrench, thread the adjuster up or down the shock to obtain the correct ride height. One complete revolution of the adjuster nut is approximately 1/16" at the wheel. Threading the adjuster nut up the shock will raise the ride height, threading it down will lower the ride height.

60e. Lock the adjusting nut in place by tightening the adjuster nut locking screw.

61. After entire weight of truck is on the wheels, jounce the suspension and roll the truck forward and backward to alleviate suspension bind. **THIS IS NECESSARY BEFORE MEASURING RIDE HEIGHT.**

62. Recheck your ride height. If you need to readjust, repeat **Steps 60-62.**

Any time you replace front suspension components, you should have the alignment checked.

Suggested Alignment Specs:

Camber: 0 to -.75 degrees

Caster: +5.5 to + 7.5 degrees

Toe: 1/16" to 1/8" toe in



Torque Specs & Shock Adjustment

COMPONENTS	TORQUE
UPPER SHOCK MOUNT TO FRAME	69 FT-LBS
UPPER SHOCK TO MOUNT	75 FT-LBS
LOWER SHOCK BOLT	125 FT-LBS
UPPER BALL JOINT	50 FT-LBS
UPPER CONTROL ARM TO FRAME	130 FT-LBS
REAR BUMPSTOP	35 IN-LBS
REAR UPPER SHOCK MOUNT TO FRAME	35 FT-LBS

COMPONENTS	TORQUE
LOWER SHOCK MOUNT TO AXLE - OEM HARDWARE	100 FT-LBS
LOWER SHOCK MOUNT TO AXLE - 3/8" HARDWARE	35 FT-LBS
M16 CONTROL ARM AND CONTROL ARM RELOCATION	195 FT-LBS
UPPER & LOWER SHOCK MOUNTING BOLTS	75 FT-LBS
REAR SWAY BAR AXLE MOUNTS	37 FT-LBS
REAR SWAY BAR END LINKS	37 FT-LBS
PANHARD/TRACK BAR	95 FT-LBS

Shock Adjustment:

We recommend starting with the shock adjustment at 12 clicks out from full stiff. Adjust the shock full stiff (clockwise) and count the clicks as you adjust the knob counter clockwise.

Shock Adjustment 101- Single Adjustable

Rebound Adjustment:

How to adjust your new shocks.

The rebound adjustment knob is located on the top of the shock absorber protruding from the eyelet.

You must first begin at the ZERO setting, then set the shock to a medium setting of 12.



-Begin with the shocks adjusted to the ZERO rebound position (full stiff). Do this by rotating the rebound adjuster knob clockwise until it stops.

-Now turn the rebound adjuster knob counter clock wise 12 clicks. This sets the shock at 12. (settings 21-24 are typically too soft for street use).

Take the vehicle for a test drive.



-if you are satisfied with the ride quality, do not do anything, you are set!

-if the ride quality is too soft increase the damping effect by rotating the rebound knob clock wise 3 clicks.

Take the vehicle for another test drive.



-if the vehicle is too soft increase the damping effect by rotating the rebound knob clock wise 3 additional clicks.

-If the vehicle is too stiff rotate the rebound adjustment knob counter clock wise 2 clicks and you are set!

Take the vehicle for another test drive and repeat the above steps until the ride quality is satisfactory.

Note:

One end of the vehicle will likely reach the desired setting before the other end. If this happens stop adjusting the satisfied end and keep adjusting the unsatisfied end until the overall ride quality is satisfactory.