

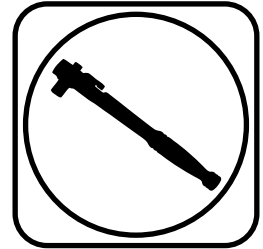

### Part # 18987999 - Universal Triangulated 4-Link

#### Recommended Tools

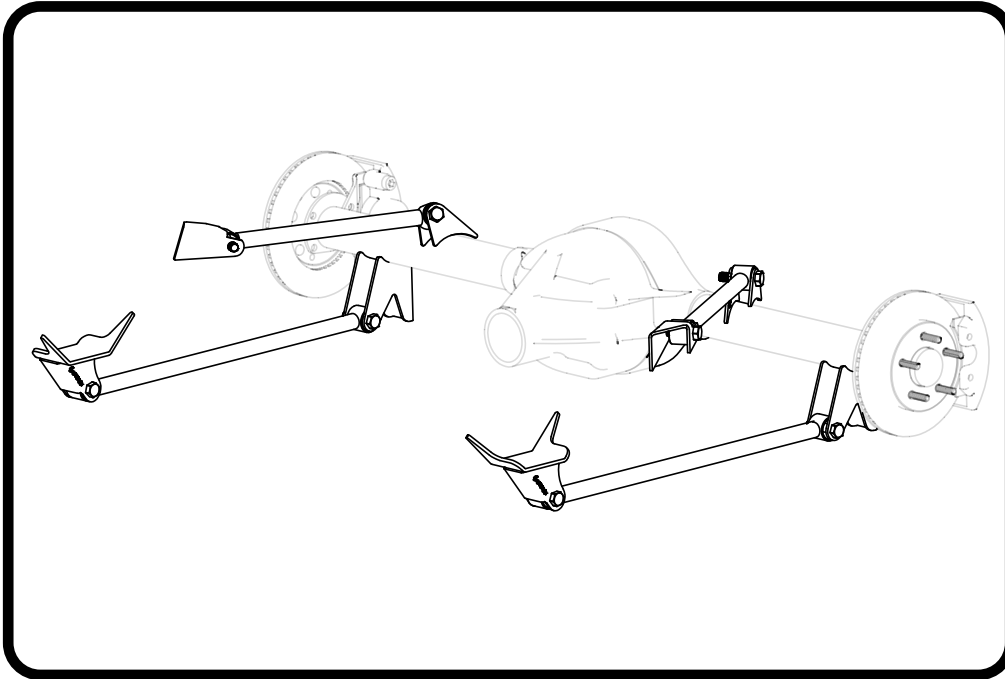

## Universal Triangulated 4-Link Installation Instructions

#### Table of contents

- Page 2..... Included Components
- Page 3..... Hardware List & Getting Started
- Page 4..... Tri-Link Installation
- Page 5..... Setting Pinion Angle

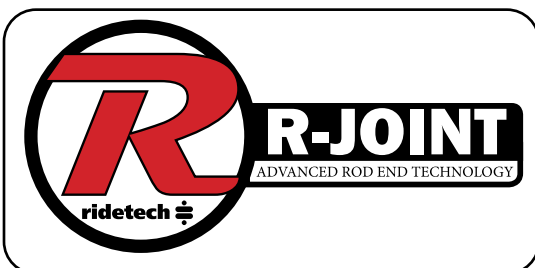



### Major Components .....In the box

Item #	Part #	Description	QTY
1	90000163	Lower bar frame bracket – Driver side	1
2	90000164	Lower bar frame bracket – Passenger side	1
3	90000159	4 link bar axle bracket	2
4	90001436	Lower 4 link bar – TW 26.50" - Set length 28 1/8" to 28 3/8"	2
5	70013364	Threaded R-Joint End (w/ R-Joints installed)	4
6	90000142	Upper bar frame bracket – Driver side	1
7	90000143	Upper bar frame bracket – Passenger side	1
8	90000144	Large Axle Tabs for upper bars	2
9	90000155	Small Axle Tab for upper bars	2
10	90001435	Upper 4 link bar – TW 15.00" - Set length 16 5/8" - 16 7/8"	2
	70013334	R-Joint Spacers	16
<b>R-Joint Components - assembled in bars and rod ends</b>			
	70013279	Retaining Ring	8
	70013280	Wavo Wave Spring	8
	70013275	Center Pivot Ball	8
	70013276	Composite Cage	8

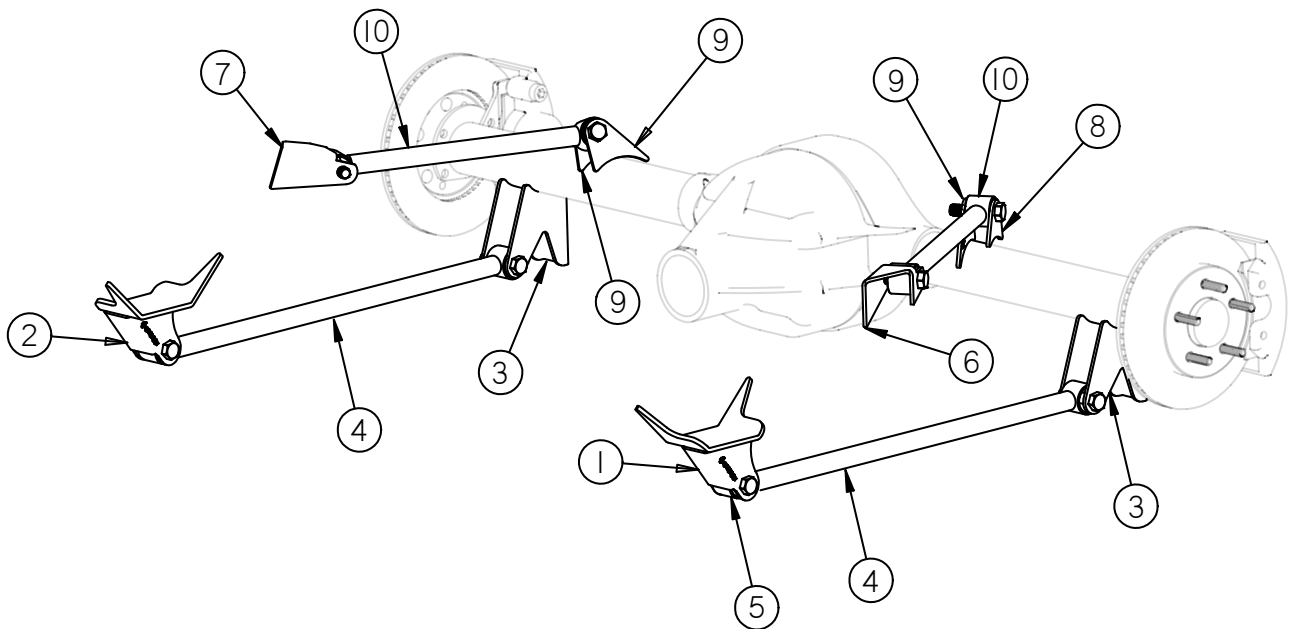



### Hardware List .....In the box (Kit# 99010025)

The Hardware Kit contains bags to help aid in selecting the correct hardware for the component being installed. The hardware list shows how the hardware is bagged.

QTY	Part Number	Description	
<b>R-JOINT ROD ENDS</b>			
4	99752004	3/4" -16 Jam Nut	R-Joint Rod Ends
<b>4 LINK BARS</b>			
8	99621003	5/8" -18 x 2 3/4" Gr. 8 Bolt	4-Link Bars to Mounts
8	99622006	5/8" -18 Nylok Jam Nut	4-Link Bars to Mounts

### R-Joint Spacer & Bar Assembly

#### R-JOINT SPACER INSTALLATION

Install the Spacers by inserting the SMALL side of the SPACER into the Center Pivot Ball. Push them in until they bottom out and stop.

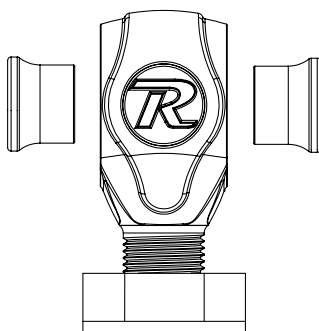

#### R-Joint Thread Engagement:

Minimum thread showing - 0  
 Nominal thread showing - 1/4"  
 Maximum thread showing - 5/8"

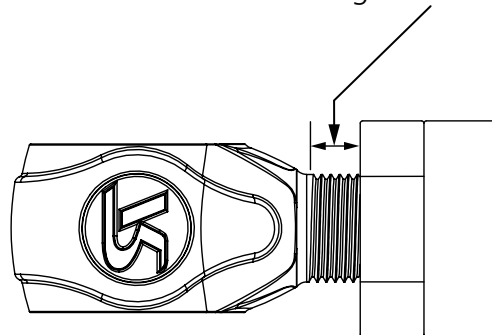

### Getting Started.....

1. If you are working on a finished vehicle with a leafspring suspension, consider leaving the leaves in until the four link is installed. This will avoid chasing the rearend around the shop during installation and will preset the location of the rearend. Be sure to double check that the rearend is centered in the car both side to side and front to back.
2. If you are starting from scratch, set the vehicle up at a comfortable working height and place the rearend under the car at ride height. Keep in mind that with an air ride system, you will be able to drop the car approx. 4" from this height by deflating the system.
3. Center the rearend side to side in relation to the frame. This is usually done by measuring from the frame to the wheel mounting or bearing flange of the rearend and making these measurements equal.



### Triangulated 4 Link Installation

4. Center the rearend in the wheel openings. The rough position should be centered in the wheel openings, but the final adjustment should make sure that the rearend is square to the frame and that the distance between the axle centerlines [front to rear] are equal on each side of the car.
5. The pinion angle should be roughly set parallel with the transmission. This will allow you enough adjustment to fine tune the pinion angle when the installation is complete. **Page 5** has some information on setting pinion angle.
6. Steps 3,4, and 5 may have to be double checked and repeated to ensure the rearend is correctly placed under the car. When you are satisfied with the placement, make sure the rearend won't move during installation. [We tack ours to the jackstands.]
7. When the rearend is correctly placed, the lower bracket /bar assembly can be placed. The 4 link kit can be installed with the lower bars under the frame or outside the frame. To determine the proper location, assemble the lower axle bracket, lower bar and the lower frame bracket together and place the lower axle bracket against the axle tube. Apply anti-sieze to the threads of the R-joint ends. Assemble the bars with 1/4" of thread showing on the shaft. This will allow for final adjustment. With the lower bar level with the car, determine the best location for the lower frame bracket. Make that decision now because that will determine the side to side location of the lower axle brackets. To place the lower bars under the frame, the lower frame bracket must be trimmed. The "wings" of these brackets will be cut off and the bracket can be placed under the frame. [Be sure to check ground clearance.]
8. When the lower frame bracket location has been determined, tack them into place. [Don't weld fully yet]
9. Place the lower axle brackets onto the axle tube at the same distance apart as the lower frame brackets. The back of these brackets should be plumb, [Perpendicular to the ground] and must be level with each other! One way to accomplish this is to tack one bracket and then use a piece of angle that is clamped across the back of the bracket to check the angle of the other. This will ensure that the lower 4 link mounting points are even from front to back.
10. Assemble the upper 4 link bar into its brackets and tabs. Assemble the bars with 1/4" of thread showing. This will allow for final adjustment. Notice that on the tabs that weld to the rearend, two of the tabs are larger. This is to compensate for the angle of the rearend housing where the tabs will be welded. The larger tabs will go to the outside of the bars. They may have to be trimmed to fit.
11. Place the upper bar assembly onto the rearend and against the frame. The rearend tabs will go in the area of the center section and the frame brackets will go against the frame at an angle. The upper bars should be as close to level as possible. [Level with the car] The frame may have to be boxed in the area where the upper frame brackets will go.

#### There are 3 main goals here:

1. Upper bars level with each other.
2. Upper bars at the same side to side distance on the axle housing. [Note that on most 9" Ford rearends, the center section is offset, so the axle tabs will appear to be located in different locations on the rearend.]
3. Upper bars at the same front to back distance on the frame.

It may take several adjustments to satisfy all of these measurements, but they must be satisfied!  
When you are satisfied that the bars are located properly, tack them in place.

12. With a floorjack, raise and lower the rearend through its travel to check for interference or binding of the rod ends. If the rearend moves freely, final welding may now be done.



### Setting Pinion Angle

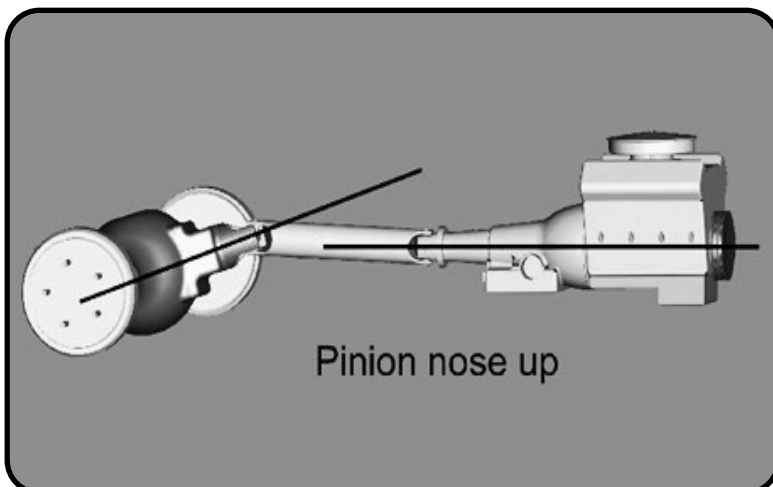
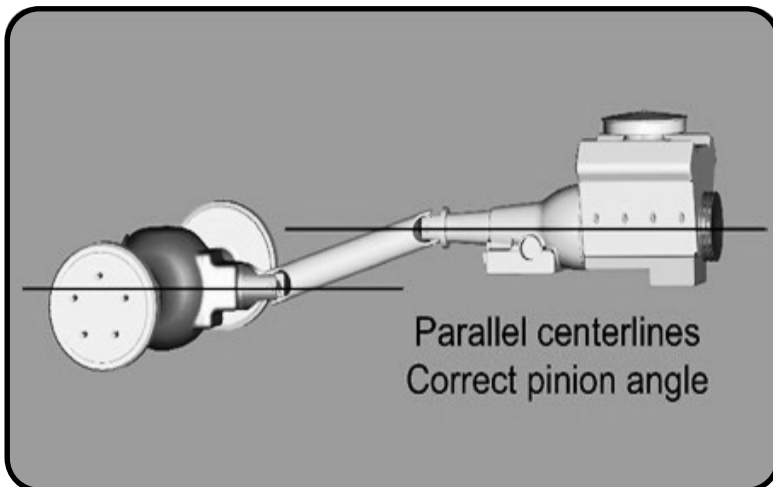
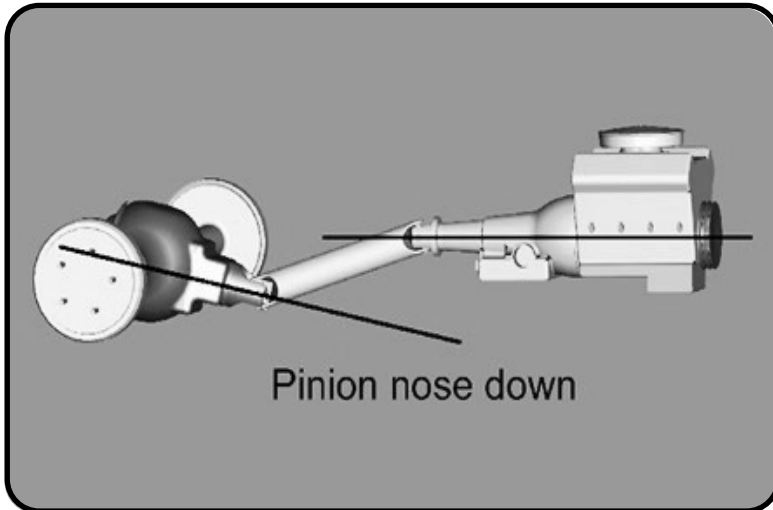

How do you set the pinion angle? On a single-piece shaft you want to set it up where a line drawn through the center of the engine crankshaft or output shaft of the transmission and a line drawn through the center of the pinion are parallel to each other but not the same line.

Your transmission angle should be around 3 degrees down in the rear. If it is more or less than 3 degrees, you might want to consider changing it. Too little angle on the transmission reduces the amount of oil getting to the rear bushing. Too much transmission angle will increase the working angles of the u-joints which will increase the wear. With the transmission at 3 degrees down in the rear, you will want to set the pinion 3 degrees up in the front.

A simple way to do this is to place a digital angle finder or dial level on the front face of the lower engine pulley or harmonic balancer. This will give you a reading that is 90 degrees to the crank or output shaft unless you have real problems with your balancer. At the other end, you can place the same level or angle finder against the front face of the pinion yoke that is also at 90 degrees to the centerline. If you rotate the yoke up or down so both angles match, you have perfect alignment.

Road testing will tell you if you have it right. If you accelerate and you get or increase a vibration, then the pinion yoke is too HIGH. Rotate it downward in small increments of a degree or two until the problem goes away. If you get or increase a vibration when decelerating, then the pinion yoke is too LOW. Rotate it upward to correct it.