



81213010 2019-2022 Chevrolet/GMC 1500

Congratulations - your new TowPro Helper Springs are quality products capable of improving the handling and comfort of your vehicle. As with all products, proper installation is the key to obtaining all of the benefits your kit is capable of delivering. Please take a few minutes to read through the instructions to identify the components and learn where and how they are used. It is a good idea to start by comparing the parts in your kit with the parts list below.

INSTALLATION INSTRUCTIONS



REQUIRES RIDE-RITE 2366 LIFT SPACER KIT (SOLD SEPARATELY) FOR INSTALL ON Z-71, HIGH COUNTRY, TRAIL BOSS, & AT4 MODELS.



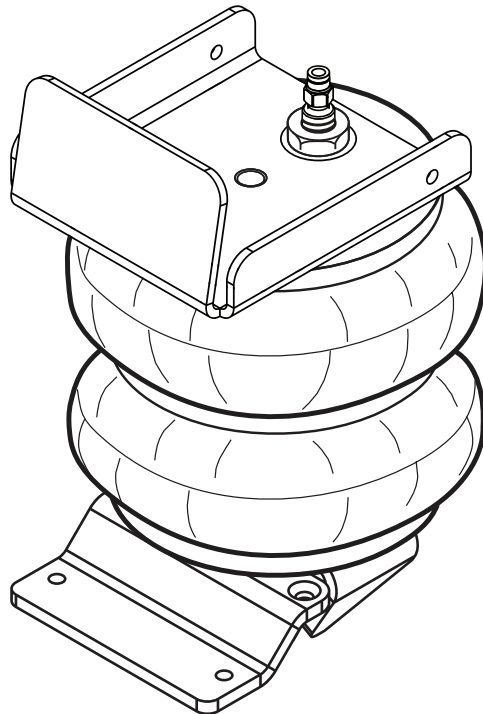

THIS KIT IS NOT FOR SILVERADO LD OR SIERRA LIMITED MODELS.
USE 81213005 KIT.



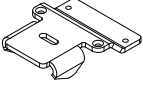

PARTS

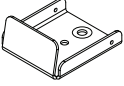
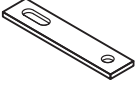
Compare the parts below to your kit. Ensure you have all pieces, and organize them for an easier installation.











MAIN KIT CONTENTS

PT # 6397	 x 2 AIR SPRING	PT # 5889	 x 2 LOWER BRACKET	PT # 1004	 x 1 HEAT SHIELD
PT # 5890	 x 2 UPPER BRACKET	PT # 5041	 x 2 BRACKET STRAP	PT # 9414	 x 1 AIR LINE TUBE (18 FEET)

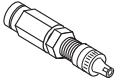
A24-760-7560 INFLATION VALVE BRACKET KIT

PT # 9483	 x 1 NO-DRILL INFLATION VALVE BRACKET	PT # 9488	 x 2 LARGE NYLON TIE
-----------	--	-----------	--

A21-760-2609 HARDWARE PACK

PT # 3033	 x 4 5/16" FLAT WASHER	PT # 3358	 x 2 M10 x 1.5 x 50mm FLAT HEAD SCREW	PT # 3510	 x 12 1/4" - 20 FLANGE NUT
PT # 3069	 x 2 3/8" - 16 x .75" FLANGE BOLT	PT # 3508	 x 4 1/4" - 20 x 1 1/2" FLAT HEAD SCREW	PT # 3032	 x 2 INFLATION VALVE AND VALVE CAP ASSEMBLY
PT # 3332	 x 2 5/8" - 18 NYLON JAM NUT	PT # 3509	 x 4 1/4" - 20 x 3/4" HEX HEAD SCREW	PT # 3055	 x 2 1/8" NPT MALE CONNECTOR
PT # 0664	 x 4 1/4" FLAT WASHER	PT # 3442	 x 4 1/4" - 20 x 1 1/2" HEX HEAD SCREW	PT # 9036	 x 6 RED NYLON TIE

CONTENTS AND OVERVIEW

PAGE 4 REMOVE JOUNCE BUMPER & INSTALL UPPER BRACKET

PAGE 5 PREP LOWER BRACKET ASSEMBLY & AIR SPRING

PAGE 6 INSTALL AIR SPRING TO LOWER BRACKET ASSEMBLY

PAGE 7 SEAT TOP OF AIR SPRING INTO UPPER BRACKET

PAGE 8 SECURE AIR SPRING TO UPPER BRACKET

PAGE 9 FINISH FASTENING THE AIR SPRING ASSEMBLY

PAGE 10 AIR LINE TUBE & INFLATION VALVE INSTALLATION

PAGE 11 INSTALL & ROUTE AIR LINE TUBE

PAGE 12 CHECKING THE SYSTEM

PAGE 13 FIXING AN AIR LEAK

PAGE 14 FINISHING THE INSTALLATION

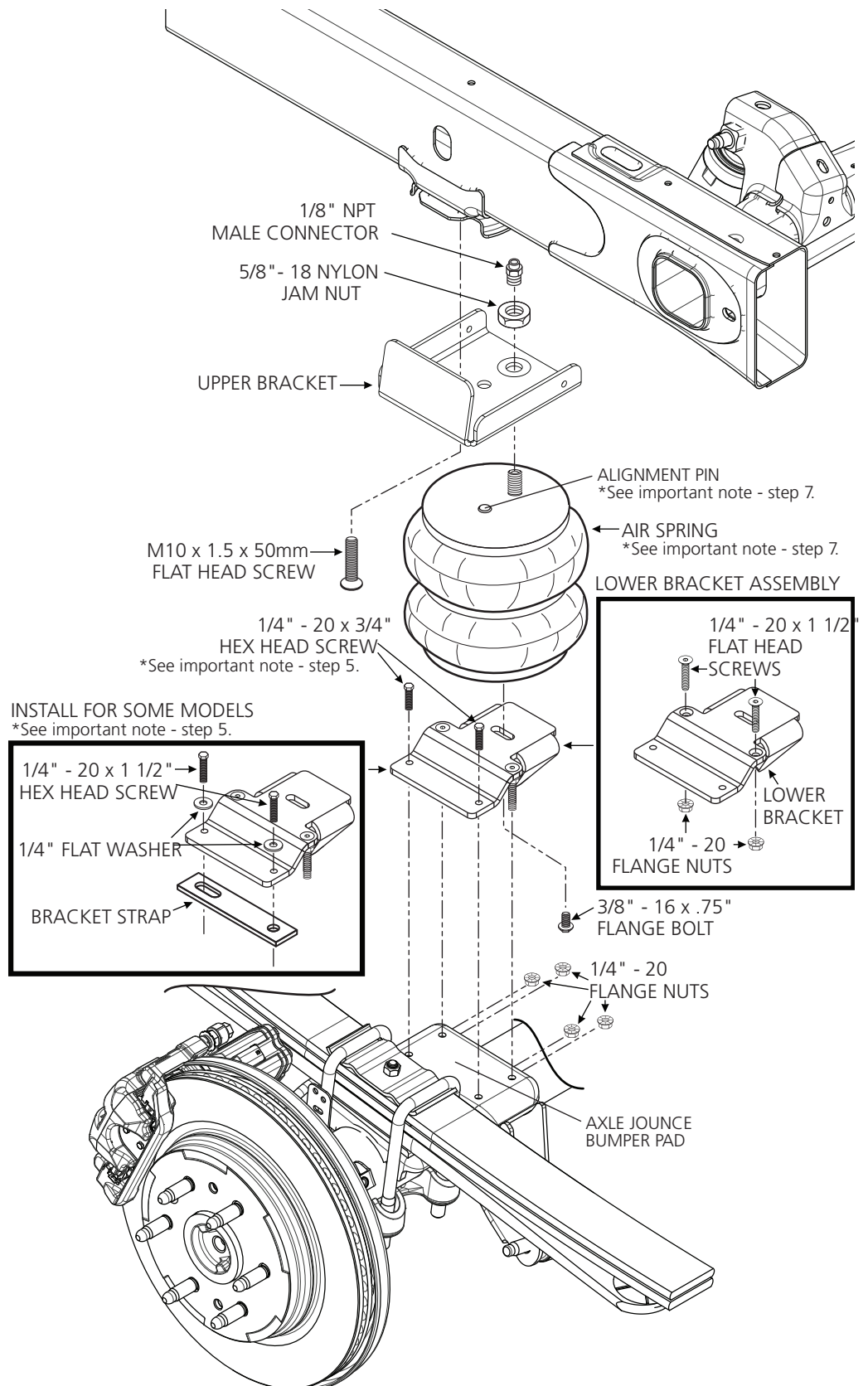

REMOVE EXISTING JOUNCE BUMPER

1

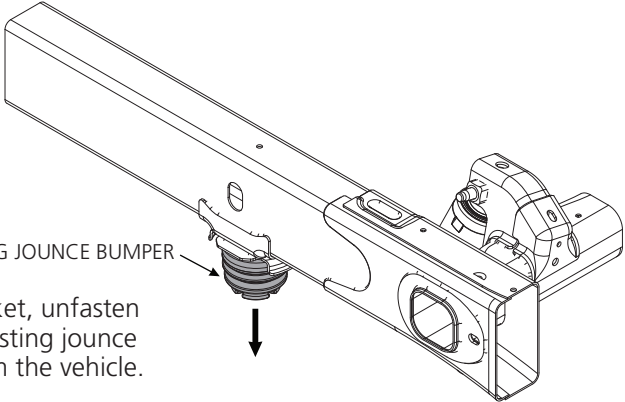

Using a 10mm socket, unfasten and remove existing jounce bumper from the vehicle.



START THE INSTALLATION ON THE RIGHT SIDE OF THE VEHICLE WHEN FACING FORWARD.

INSTALL UPPER BRACKET

2

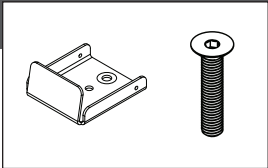

1 Place upper bracket against frame where jounce bumper was installed, assuring that the tab is on the outside of the frame.

2 Attach the upper bracket, as shown. Thread the flat head screw into the original jounce bumper bolt threaded hole and tighten to factory torque specifications.

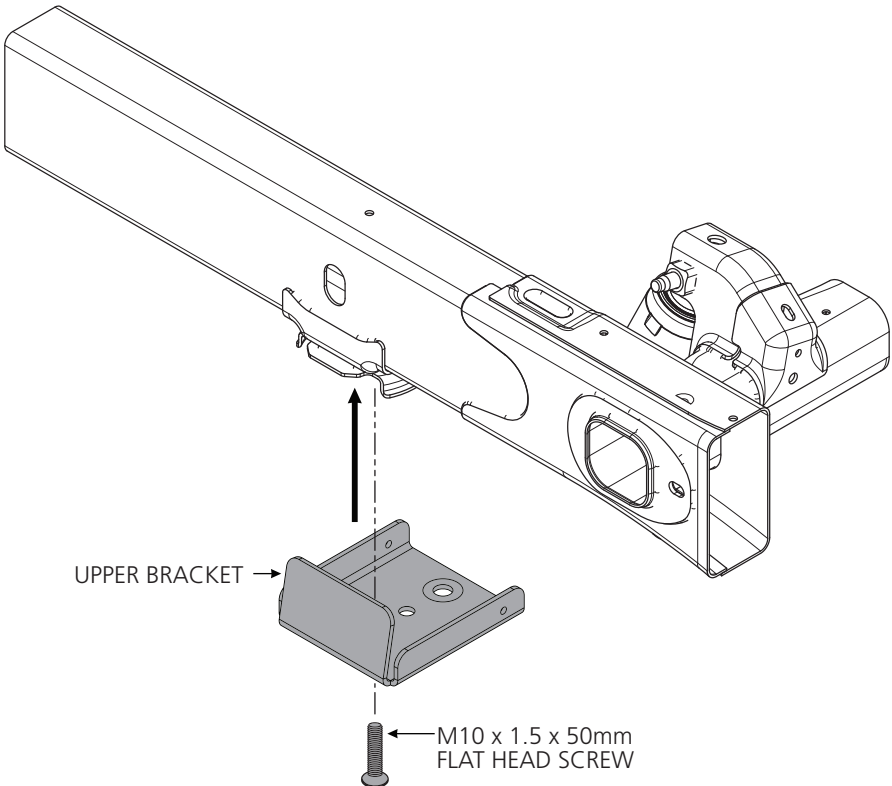

3

PREP LOWER BRACKET ASSEMBLY

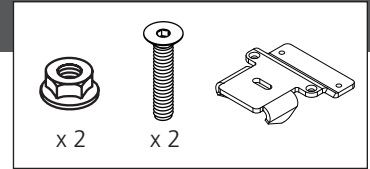
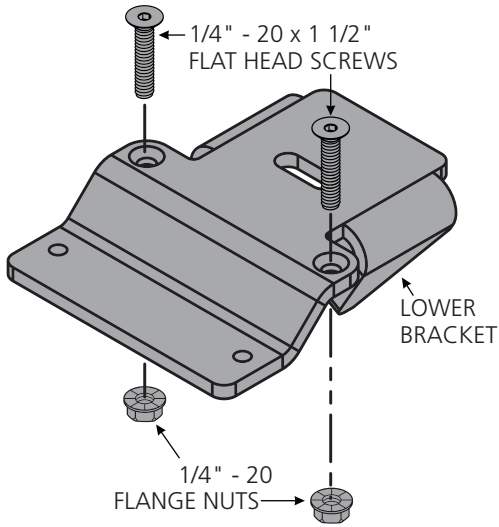

- 1 Prep the lower bracket by installing the flat head screws and flange nuts, as shown.

4

PREP AIR SPRING

- 1 Thread the 1/8" male connector into the combo stud on the air spring.

- 2 Cut a short piece of air line tube (approx. 3 inches). Insert one end of the tubing into the 1/8" NPT male connector and the other end into the inflation valve.

- 3 Using the inflation valve cap tool, depress the inflation valve pin and compress the air spring as much as possible. While holding the compressed air spring, release the inflation valve pin. The air spring will stay compressed and is ready for installation.

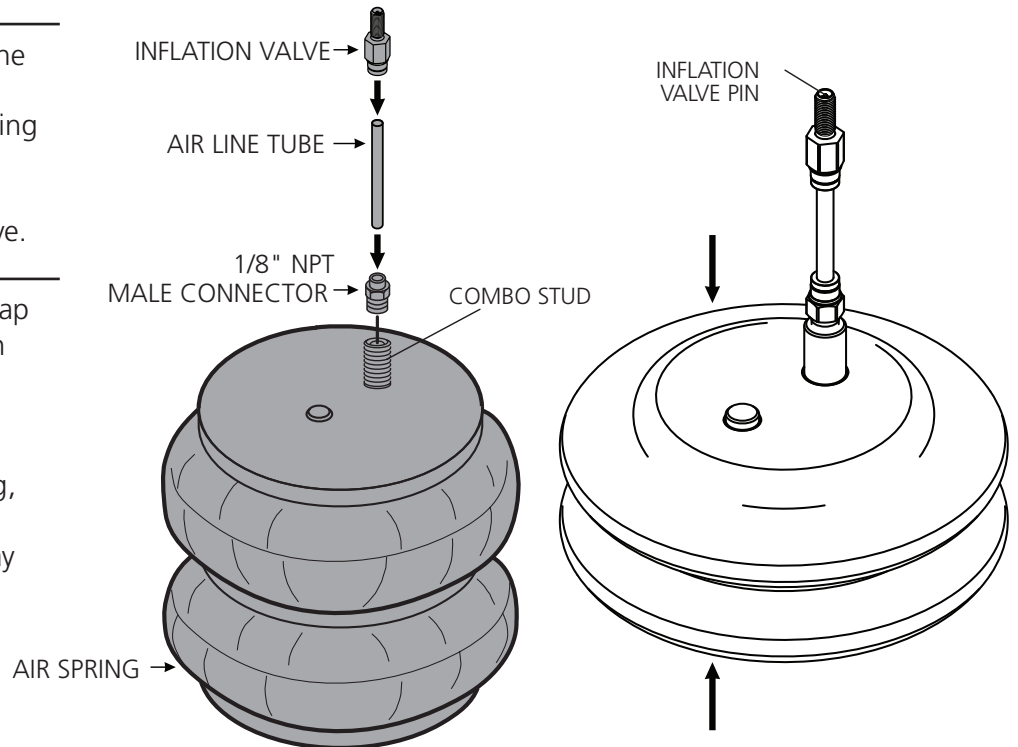
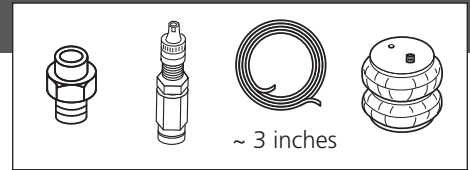

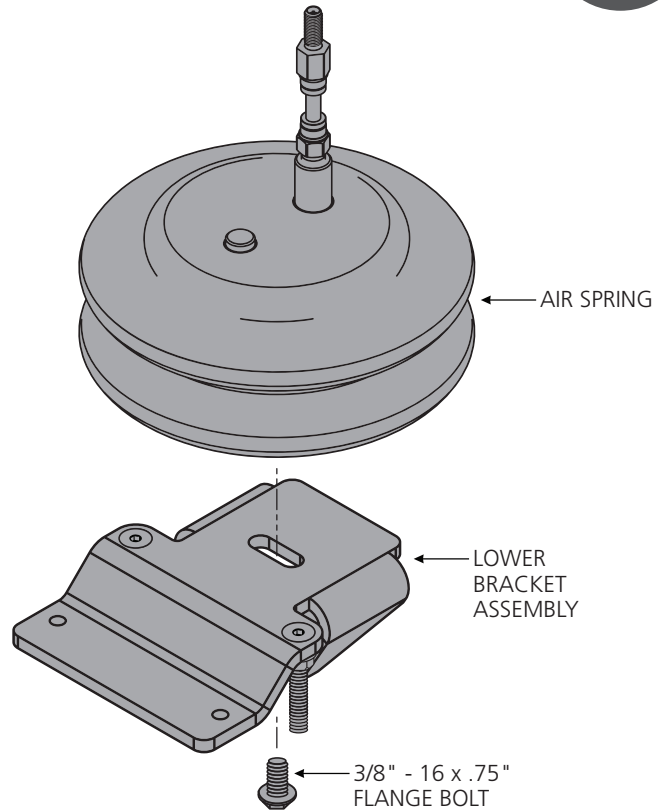
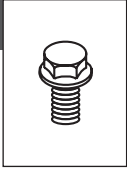

1 Attach the air spring to the lower bracket, as shown. DO NOT FULLY TIGHTEN THE BOLT.



DO NOT FULLY TIGHTEN THE BOLT AT THIS STAGE. TORQUE TO SPEC IN STEP 8.

2 Set the air spring assembly into place by inserting the two pre-installed screws into the inner two holes on the axle jounce bumper pad. See if the lower bracket rests evenly on the axle jounce bumper pad. If not, the bracket strap and associated hardware will be required in step 8.

RIGHT SIDE VIEW FROM FRONT

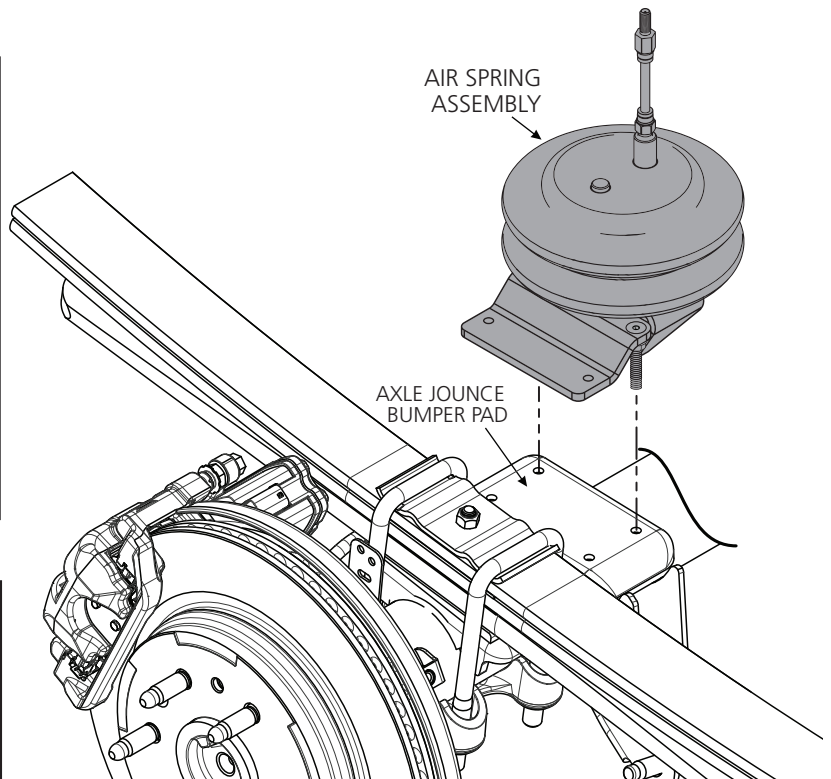
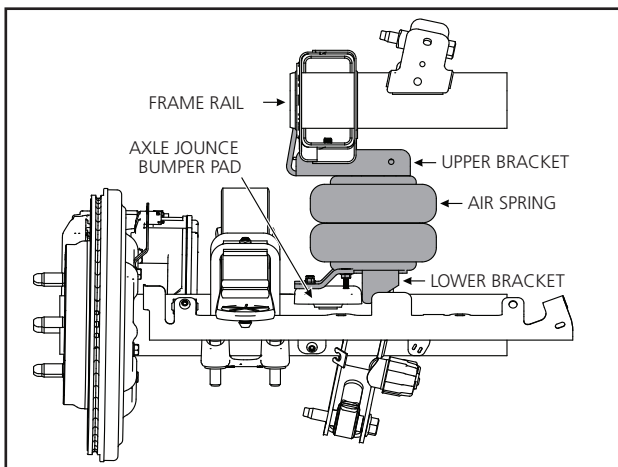

SEE STEP 8 FOR DETAILS ON BRACKET STRAP

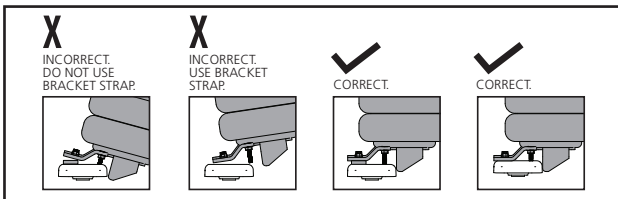

6

SEAT TOP OF AIR SPRING INTO UPPER BRACKET



Right side only

1 If installing the right side, install the heat shield, as shown. Position the heat shield so it is between the air spring and the nearest heat source.

2 Guide the inflation valve and air line tube through the large hole in the upper bracket.

3 While depressing the inflation valve pin to allow air into the air spring, rotate the air spring, if necessary, until the combo stud is fitted through the large hole in the upper bracket.

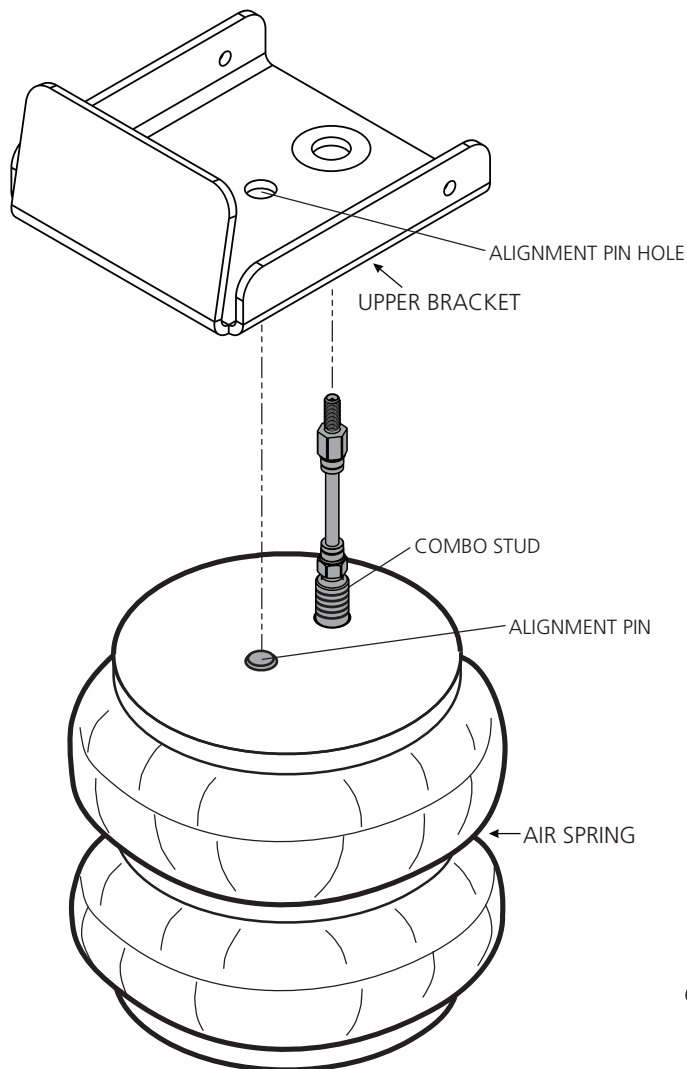

RIGHT SIDE ONLY -
INSTALL HEAD SHIELD

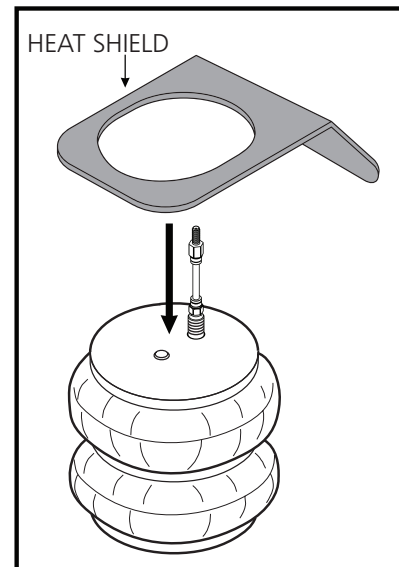

USE YOUR HAND TO CHECK FOR THE PROPER CLEARANCE AROUND THE AIR SPRING. IF YOUR HAND DOES NOT FIT BETWEEN THE AIR SPRING AND OTHER COMPONENTS, IT WILL RUB!



- 1** Remove the air line tube from the air fitting on top of the air spring (see step 10-4 for removal instructions).
- 2** Make sure that the alignment pin on top of the air spring has fully seated into the alignment pin hole in the upper bracket. It will "click" into place once seated correctly.
- 3** Fully tighten the nut to the combo stud.

VIEW ON VEHICLE

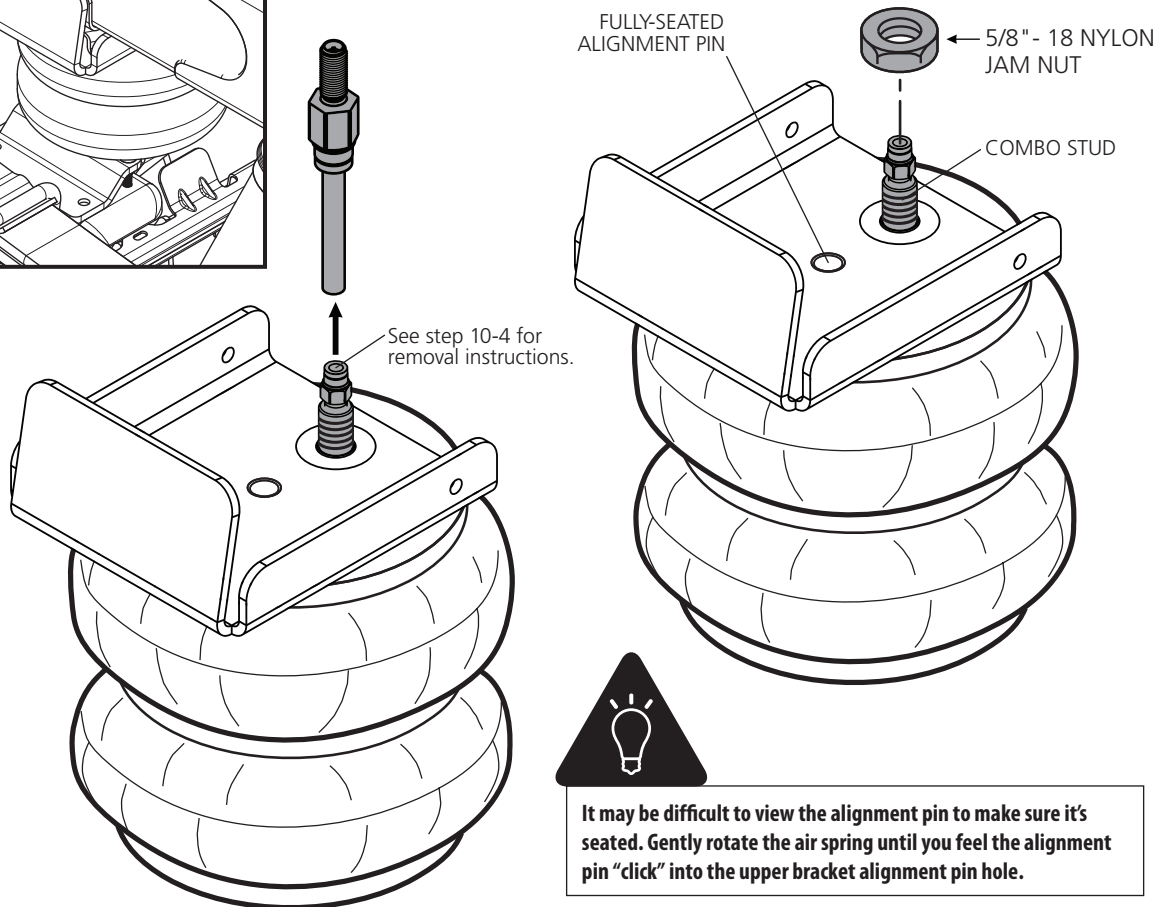
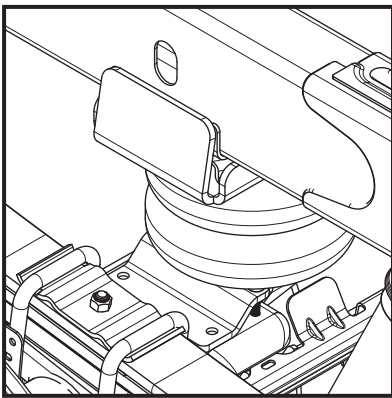

ALIGNMENT PIN ON AIR SPRINGS MUST BE INSTALLED TO FULLY SEAT INTO ONE OF THE ALIGNMENT HOLES IN THE UPPER BRACKET. FAILURE TO DO SO WILL CAUSE IT TO BE PUSHED INTO THE BEAD PLATE, CREATING AN AIR LEAK, AND RESULTING IN AN AIR SPRING FAILURE THAT IS NOT WARRANTABLE. THE ALIGNMENT PIN CANNOT HOLD 2,500 LBS! IT IS USED FOR ALIGNMENT ONLY!



It may be difficult to view the alignment pin to make sure it's seated. Gently rotate the air spring until you feel the alignment pin "click" into the upper bracket alignment pin hole.

8

FASTEN THE AIR SPRING ASSEMBLY TO THE AXLE JOUCE BUMPER PAD

Most applications do not require the bracket strap and associated hardware. Use only if it assists in aligning the lower bracket to the axle jounce bumper pad. Review step 5 for correct alignment.

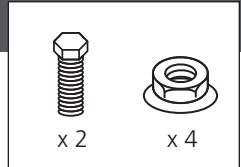

1 Install the hex head screws into the two remaining outside holes in the axle jounce bumper pad, as shown.

2 Attach the flange nuts to all four screws and tighten. Alternate tightening to draw lower bracket evenly to axle jounce bumper pad.

3 Using an open-end wrench, fully tighten 3/8" - 16 x .75" bolt on the bottom of the air spring.

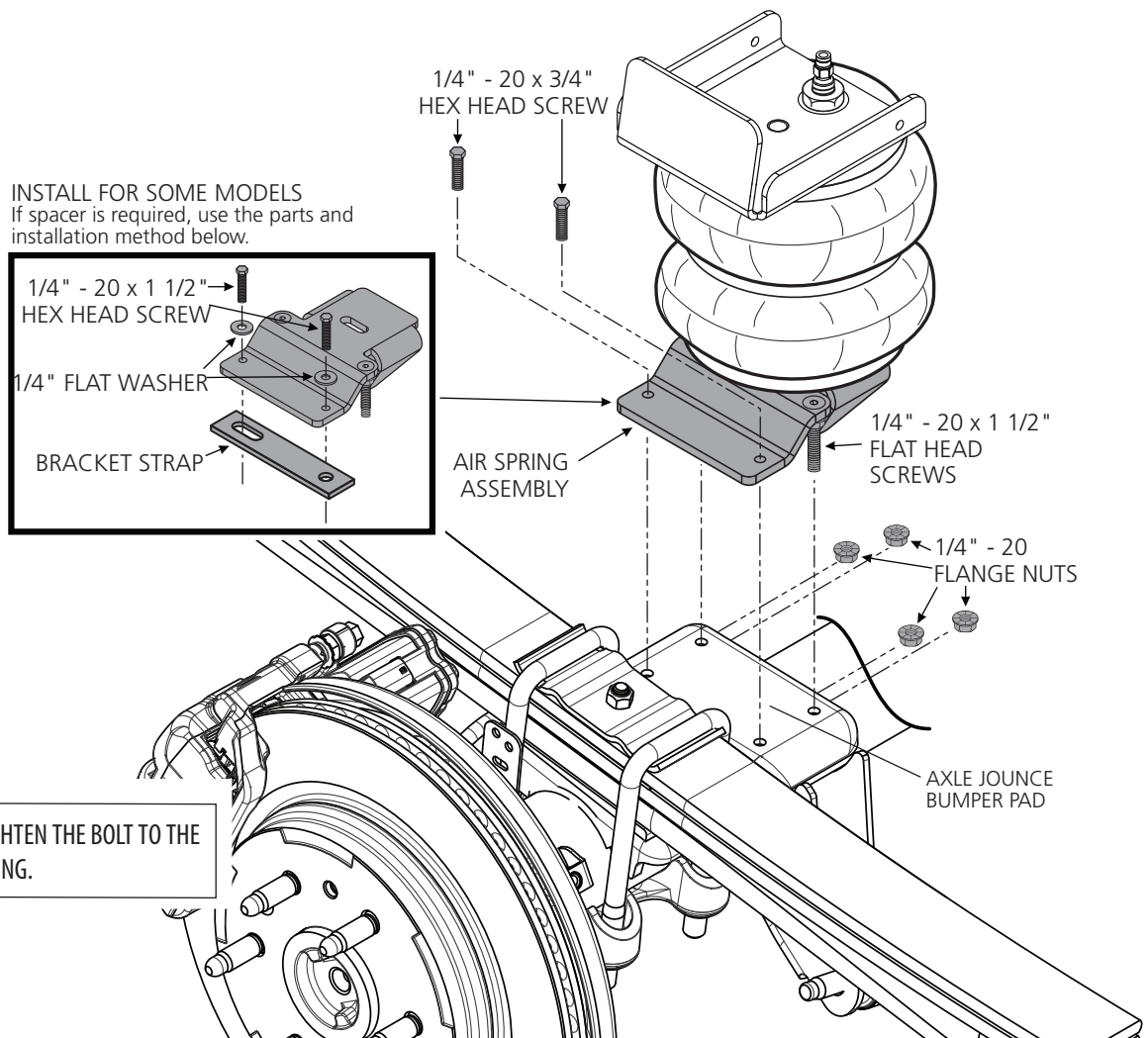

REMEMBER TO FULLY TIGHTEN THE BOLT TO THE BOTTOM OF THE AIR SPRING.



The factory rear brake line guard may be repositioned to gain better access to lower bracket fasteners. To perform this step, remove the three button-head fasteners using a T40 Torx bit. Gently release the plastic retainers on the guard from the brake line and carefully reposition it as needed for access to the bracket fasteners. Once the bracket fasteners are tightened (in this step), reposition the brake line guard, reinstall the Torx fasteners, and tighten them to the factory recommended torque specification.



AWESOME! You're done with the right side. Repeat steps 1-8 for the left side, then continue to step 9.

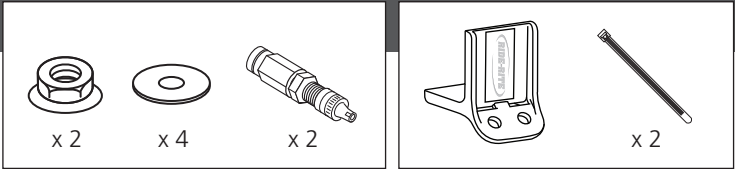

IF USING THE OPTIONAL NO-DRILL INFLATION VALVE BRACKET, CHOOSE OPTION 1. IF DRILLING, CHOOSE OPTION 2. INFLATION VALVES MUST BE ACCESSIBLE BY AN AIR CHUCK.

1 Secure the air Inflation valve bracket to a protected, secure location. PROCEED TO STEP 3.

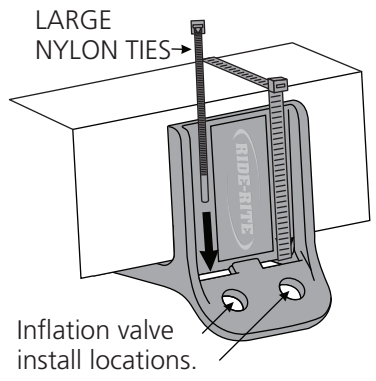

2 Select a protected location to install the inflation valves, such as the bumper or the body of the vehicle.

Drill two 5/16" holes for inflation valve install locations.

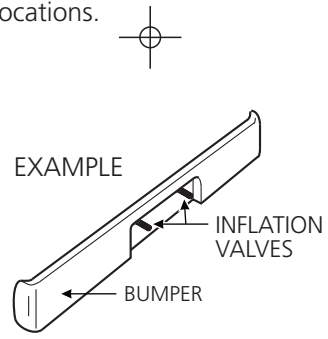

3 Install inflation valve assembly as shown.

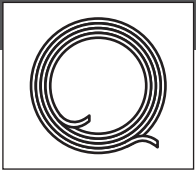
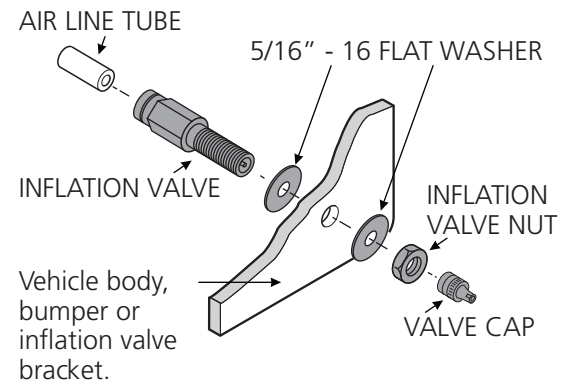

1 Match air line tube ends.



2 Find center of air line tube, make a square cut with tube cutter or sharp utility knife.

DO Make sure the cut is as square as possible. Use a tube cutter or sharp utility knife.

DON'T Fold or kink the air line tube. Cut the air line tube at an angle. Use pliers, scissors, snips, saws, or side cutters.

PROPER AND IMPROPER CUTS IN THE AIR LINE TUBE

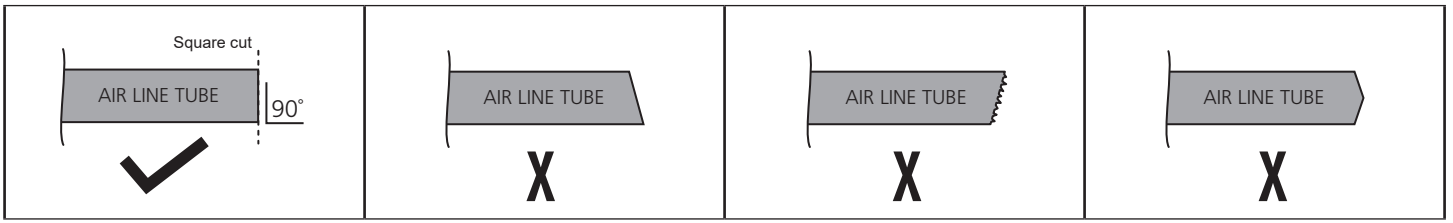

11

INSTALLING AIR LINE TUBE INTO AIR FITTINGS AND INFLATION VALVE

1 Insert end of air line tube into air fitting.

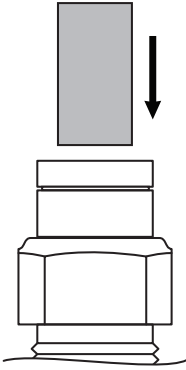

2 Push air line tube into air fitting as far as possible.

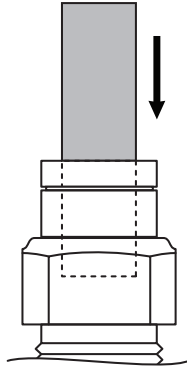

3 Gently pull on the air line tube to check for a secure fit.

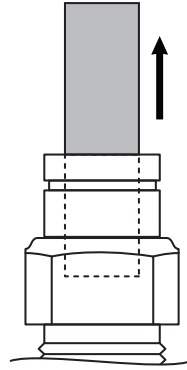

4 To remove, push down collar and gently pull air line tube away.

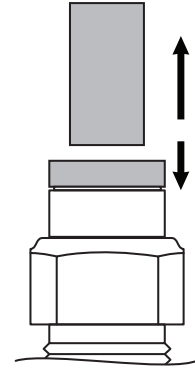

Removal Tip: Use a 1/4", 5/16", or 6mm open-ended wrench to push the collar down.

12

ROUTE AND SECURE AIR LINE TUBES

Air line tube routes will vary, depending on your truck, and requires you to choose the best path from the air springs to the inflation valves. Use the instructions below to help you choose.

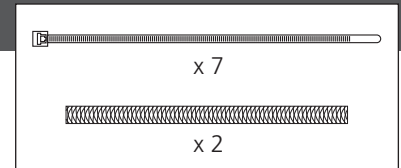

DO

Select routes protected from heat, debris, and sharp edges.
Use thermal shields near heat sources.
Use Nylon ties to secure the air line tube.

DON'T

Bend or sharply curve air line tubes.
Leave air line tube exposed to sharp edges.
Use unnecessary lengths of air line tube.
Route air line tube near moving parts.
Let air line tube hang unsecured from vehicle.
Scar air line tube while routing.

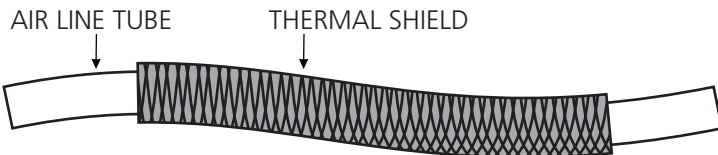

USE SUPPLIED THERMAL SHIELDS WHEN AIR LINE TUBE RUNS WITHIN 6 INCHES OF HEAT SOURCES.

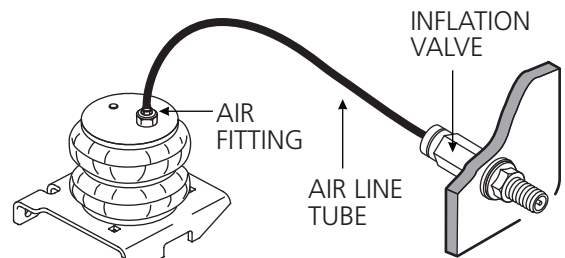

- 1** Place an air chuck onto the inflation valve and fill the system to 70 PSI .

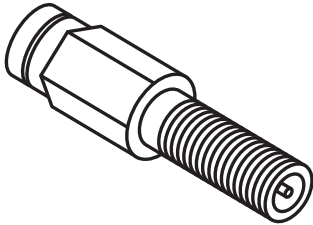

AIR SPRINGS INFLATE QUICKLY. CHECK AIR PRESSURE WHILE INFLATING.

- 2** Spray fittings with soap and water mixture.



- 3** Observe bubbles.

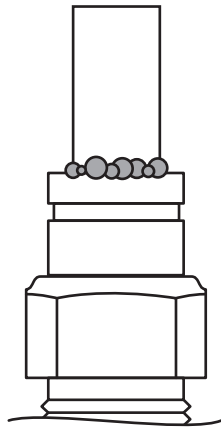

SMALL SOAP BUBBLES
THAT DO NOT EXPAND

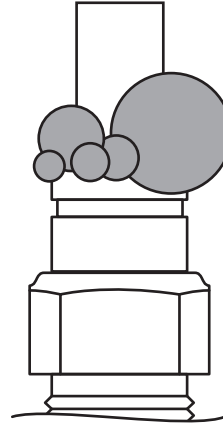

SOAP BUBBLES
THAT EXPAND



NO LEAKS?

Congratulations! Continue to step 15 to finish installation. Review the Operating Instructions.

LEAK?

Bummer. Continue to step 14 to fix the leak.

14

FIXING AN AIR LEAK

- 1 Press the air valve on end of inflation valve to release all air pressure.

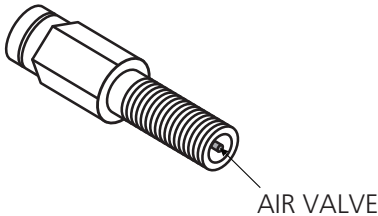

EXHAUST ALL AIR FROM THE SYSTEM PRIOR TO RELEASING AIR LINE TUBES FROM AIR FITTINGS.

LEAK AT AIR LINE TUBE AND AIR FITTING

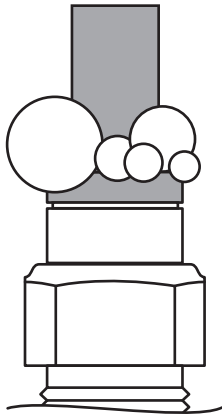

Release air line tube (see page 12). Review proper cuts and procedures in step 10. Repeat steps 11 and 13.

LEAK AT BASE OF AIR FITTING ON AIR SPRING

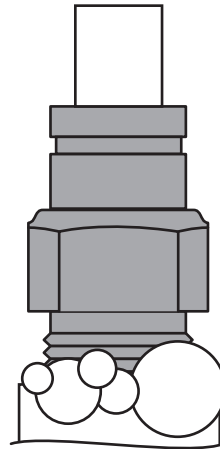

Tighten air fitting one turn or until leak stops.

LEAK OUT OF THE VALVE CORE ON INFLATION VALVE

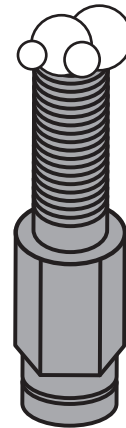

Tighten valve core with valve core wrench on inflation valve cap.

STILL HAVE A LEAK?

Refer to the Troubleshooting section of the Instruction Manual. If the leak persists, or if there is an issue with a leaking part, call 1-812-482-2932.

SAFELY RETURN VEHICLE TO OPERATIVE STATE

If you removed any wheels during installation, install the wheels and torque the lug nuts to the manufacturer's specifications.

Safely remove any jack stands and wheel chocks used during installation.

Re-attach the negative battery cable.

DOUBLE-CHECK AIR SPRING CLEARANCE

Check the air springs once again for the proper 1/2" minimum clearance. Perform clearance check again when vehicle is under load.

VEHICLE GVWR

NEVER exceed the maximum load recommended by the vehicle manufacturer (GVWR). The GVWR can be found in your vehicle's owner's manual or on the data plate on the driver's side door. Consult your local dealership for additional GVWR specifications.

READ AND UNDERSTAND THE OPERATING INSTRUCTIONS

The Ride-Rite system can improve handling and comfort. Take the time to learn how to properly use and maintain your investment by reading the Operating Instructions.



USE YOUR HAND TO CHECK FOR THE PROPER CLEARANCE AROUND THE AIR SPRING. IF YOUR HAND DOES NOT FIT BETWEEN THE AIR SPRING AND OTHER COMPONENTS, IT WILL RUB!

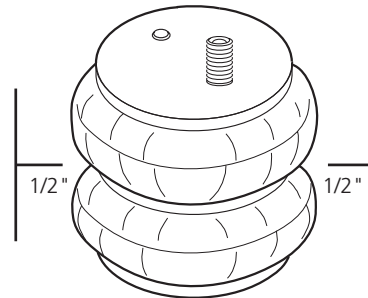

! IMPORTANT

A MINIMUM OF 5 PSI MUST BE MAINTAINED IN THE AIR SPRINGS AT ALL TIMES

Too much air pressure in the air springs will result in a firmer ride, while too little air pressure will allow the air springs to bottom out over rough conditions, and will not provide the improvement in handling that is possible.

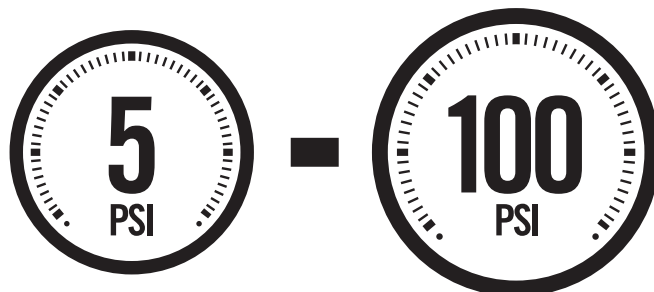

MINIMUM PRESSURE

MAXIMUM PRESSURE (LOADED)

BEFORE YOU DRIVE, CONFIRM THE FOLLOWING:

- Do you have a minimum of 5PSI in your air springs?
- Are your air springs standing 5 1/2" - 6 1/2" tall?
- Are your air springs properly aligned, left-to-right and front-to-back?
- Are your nuts and bolts tight?
- Put your paper work back into the sleeve and keep it in your glove compartment for future reference.
- You've been bagged...and now your suspension is Airide equipped! Show it off with the supplied decal!

5 1/2" - 6 1/2"

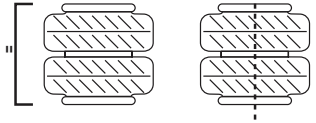

NEED INSTALLATION HELP? 1-812-482-2932

