



81223008 2005-2007 F250, F350 4WD

Congratulations - your new TowPro Helper Springs are quality products capable of improving the handling and comfort of your vehicle. As with all products, proper installation is the key to obtaining all of the benefits your kit is capable of delivering. Please take a few minutes to read through the instructions to identify the components and learn where and how they are used. It is a good idea to start by comparing the parts in your kit with the parts list below.

Components

224C AIR SPRING	6401	2
UPPER BRACKET	5462	2
LOWER BRACKET	5463	2
JOUNCE STOP BRACKET	5465	2
SPACER BRACKET	5473	2
1/2" SPACER	5477	2
FUEL LINE BRACKET	5428	1
BAIL CLAMP	3077	2
HEAT SHIELD	1004	1

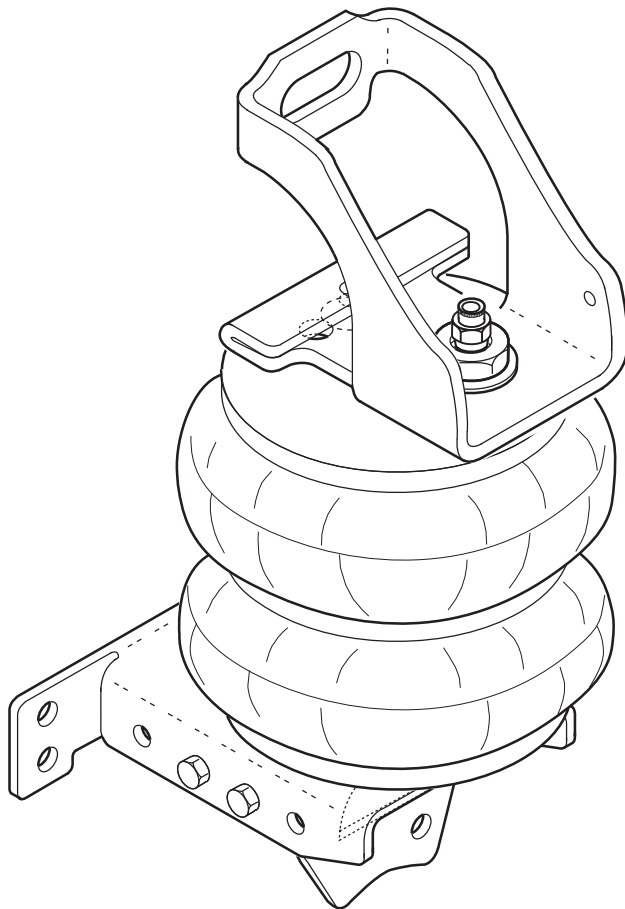

Hardware

5/16" - 24 X 3/4" HEX HEAD BOLT	1
5/16" - 24 FLANGE NUT	1
5/16" FLAT WASHER	4
3/8"-16 X 3/4" HEX HEAD BOLT	2
3/8"-16 X 1" HEX HEAD BOLT	12
3/8"-16 X 2 1/2" FLAT HEAD BOLT	2
3/8"-16 FLANGE LOCK NUT	18
3/8" LARGE FLAT WASHER	2
3/4"-16 X 3" HEX BOLT	2
3/4"-16 HEX HEAD NUT	2
3/4" INTERNAL TOOTH LOCK WASHER	2
3/4" LOCK WASHER	2
3/4" LARGE FLAT WASHER	8

WARNING!

Do not inflate this assembly when it is unrestricted. The assembly must be restricted by the suspension or other adequate structure. Do not inflate beyond 100 P.S.I. Improper use or over inflation may cause property damage or severe personal injury.

UPPER BRACKET ATTACHMENT

FIGURE "A"

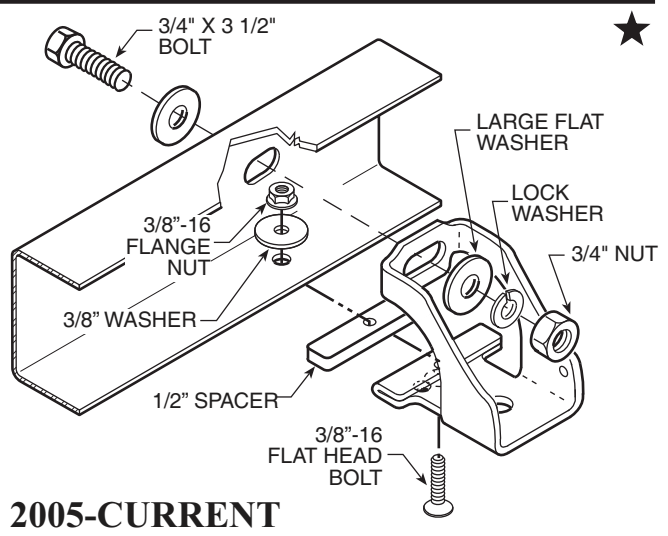
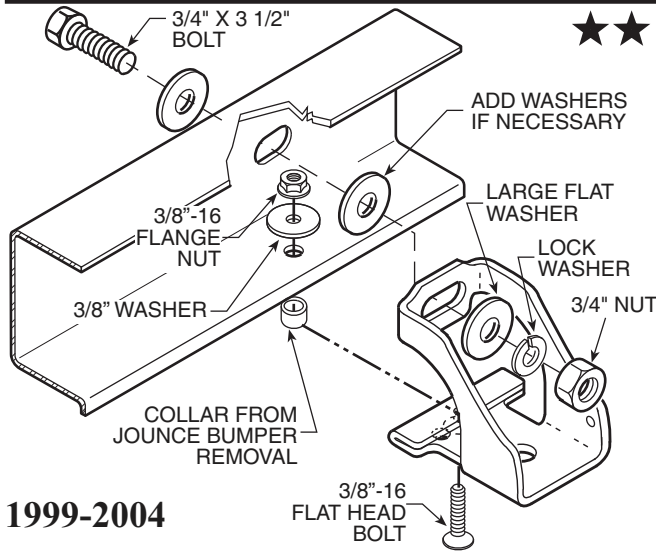

PREASSEMBLY

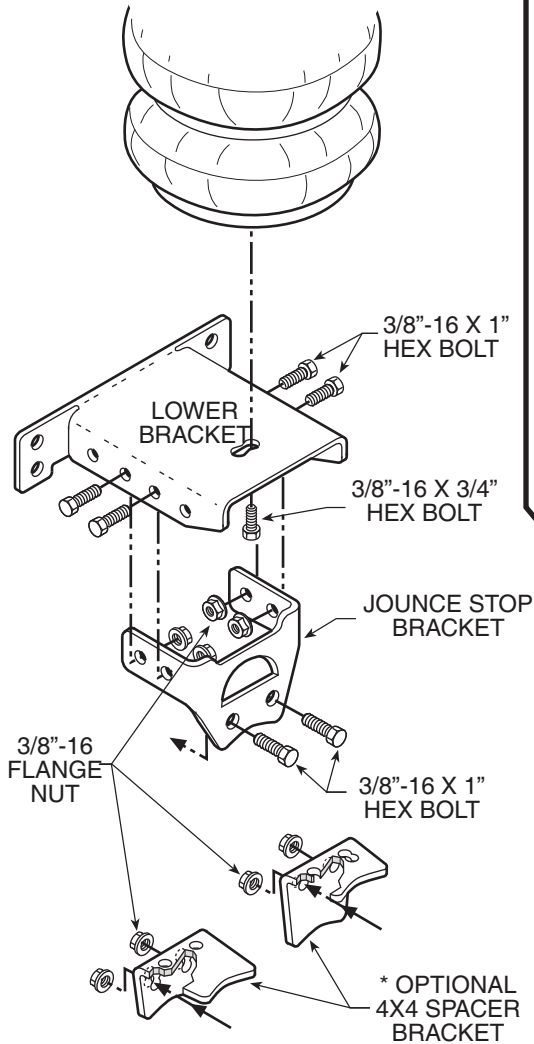

***NOTE:** AN ADDITIONAL SPACER MAY BE NECESSARY FOR SOME 4X4's. IF THE SPACER IS REQUIRED, USE THE SPACER THAT BEST FITS THE VEHICLE.

KIT TO VEHICLE INSTALLATION

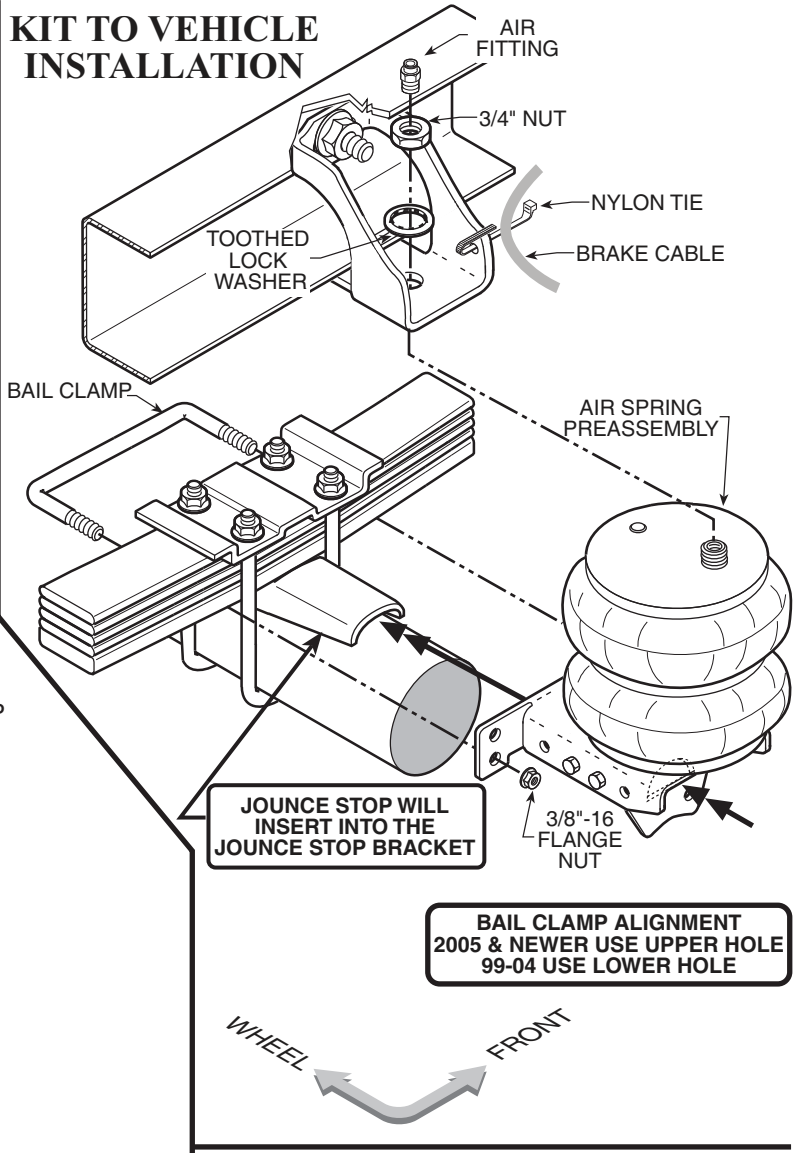

NOTE: KIT INSTALLATION WILL VARY BETWEEN YEARS AND MODELS. PLEASE READ INSTRUCTIONS CAREFULLY.

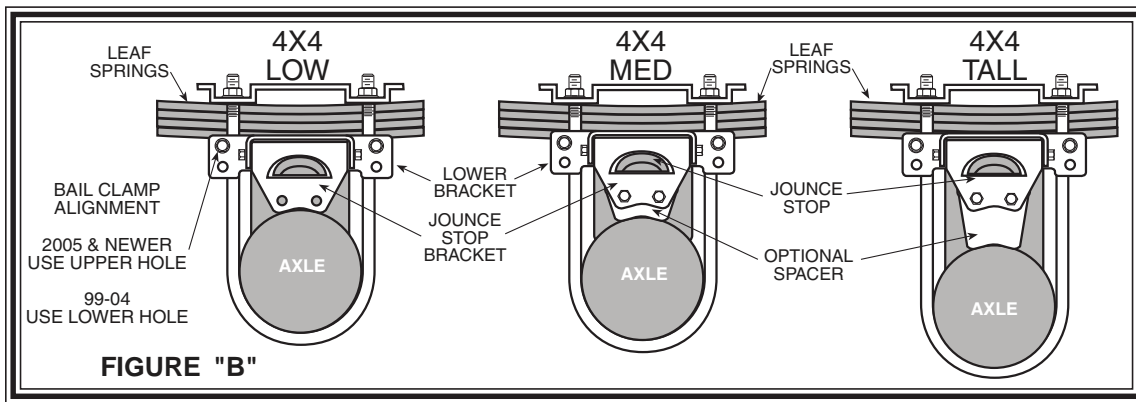
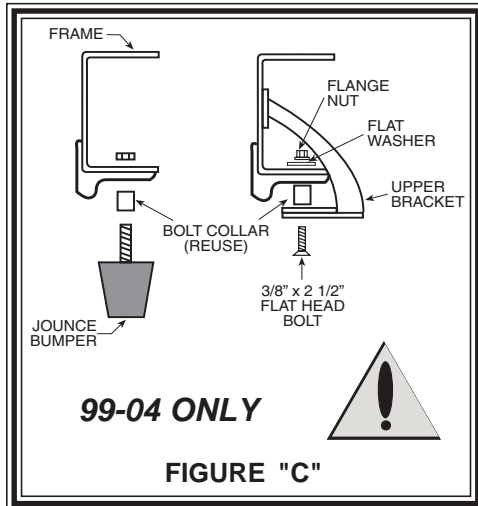

FIGURE "B"



99-04 ONLY

FIGURE "C"

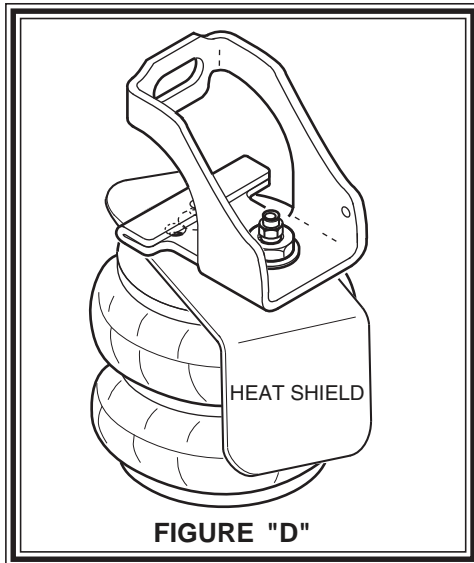

FIGURE "D"

STEP 1 - PREPARE THE VEHICLE

On 2005 and newer vehicles some lines must be repositioned on the left side of the vehicle. Remove the nut holding the fuel line retaining clip. Rotate the retaining clip 90 degrees with the stud facing down. Install the relocating bracket with the nut previously removed. Next, fasten the retaining clip to the relocation bracket using a 5/16"-24 x 3/4" bolt and 5/16"-24 flange nut.

Your vehicle is equipped with rubber jounce bumpers attached to the frame directly above the axle. Remove these bumpers by un-bolting from the inside of the frame flange. These bumpers will not be re-used with this kit. On vehicles from 1999 to 2004 you will have to remove the collar from the jounce bumper bolt which will be re-used in **Step 2B**.

STEP 2A - UPPER BRACKET INSTALLATION, 2005 & NEWER ★

Insert the 3/8"-16 x 2-1/2" flat head bolt into the upper bracket and then slide the spacer over the bolt. Install the upper bracket onto the frame. Make sure that no part of the vehicle's wiring will be pinched between the upper bracket and the frame. Tighten the 3/8"-16 flat head bolt with a 3/8"-16 flange nut and the large 3/8" washer. Install the 3/4"-16 x 3" hex bolt thru the existing hole in the frame rail and upper bracket. Secure the 3/4" bolt with a 3/4" flat washer, 3/4" lock washer and, 3/4" hex nut.

If you have existing hitch hardware, the 3/4" bolt should be long enough to extend thru the upper bracket, truck frame and the hitch brackets (if present). Be sure to use at least one of the large flat washers and lock washer before putting the 3/4" nut onto the bolt. Finally, the emergency brake cable will have to be tie-wrapped out of the way using the hole provided in the upper bracket. *See Figure "A"*.

STEP 2B - UPPER BRACKET INSTALLATION, 1999-2004 ★★

Insert the 3/8"-16 x 2-1/2" flat head bolt into the upper bracket. Place the collar that was on the jounce bumper back where it was. *See Figures "A" & "C"*. Install the upper bracket onto the frame. Make sure that no part of the vehicle's wiring will be pinched between the upper bracket and the frame. Tighten the 3/8"-16 flat head bolt with a

3/8"-16 flange nut and the large 3/8" washer. Install the 3/4"-16 x 3" hex bolt thru the existing hole in the frame rail and upper bracket. Secure the 3/4" bolt with a 3/4" flat washer, 3/4" lock washer, and 3/4" hex nut.

If you have existing hitch hardware, the 3/4" bolt should be long enough to extend thru the upper bracket, truck frame and the hitch brackets (if present). Be sure to use at least one of the large flat washers and lock washer before putting the 3/4" nut onto the bolt. Finally, the emergency brake cable will have to be tie-wrapped out of the way using the hole provided in the upper bracket. *See Figures "A" & "C"*.

STEP 3 - LOWER BRACKET INSTALLATION

Fasten the lower bracket to the bottom of the air spring finger tight. Next, install the jounce stop bracket onto the lower bracket using four 3/8"-16 x 1" bolts and 3/8"-16 flange nuts. Be sure to capture the jounce bumper tongue with this bracket. If the jounce stop bracket does not touch the axle a spacer bracket will have to be used. If there is a small gap, use the short side. If there is a large gap, use the tall side. *See Figures "A" & "B"*.

Important:

In order for the air spring to function properly, there must be a minimum of 1/2" of clearance around the air spring.

Install the spacer bracket using two 3/8"-16 x 1" bolts and 3/8"-16 flange nuts. Install the bail clamp around the axle perch and install the 3/8"-16 flange nuts onto the bail clamp and tighten. Finally tighten up the 3/8"-16 flange bolt into the air spring. *See Figures "A" & "B".*

STEP 4 - AIR SPRING INSTALLATION

The heat shield will be used on the right side of the truck where the exhaust pipe is closest to the air spring. It is placed between the upper bracket and the top of the air spring. The top of the air spring has a button which will be put into the hole in the upper bracket towards the front of the truck on both sides. When the air spring is in place and properly lined up, place the internal tooth lock washer and the 3/4" hex nut onto the top stud of the air spring. On the right side move the heat shield into alignment before tightening the top nut on the air spring. Make sure the heat shield will not interfere with the normal operation of the air spring or the vehicle's suspension. Do not position the face of the shield directly over the axle, as it may contact the axle on full suspension compression. *See Figure "D".*

Install the air fitting into the top stud of the air spring. Tighten the air fitting securely to engage the orange thread sealant.

Notice:

**4X4 FORD
SUPER DUTY**

On some models with the tall jounce bumper stop, the lower bracket will have to be modified to fit level with the axle.

The opening of the lower bracket will have to be made a 1/16" to an 1/8" wider, where the bracket contacts the jounce stop, to make the bracket level with the axle.

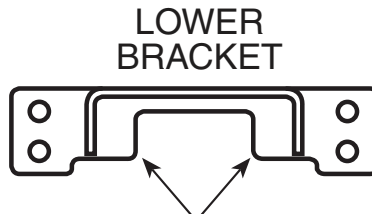

**IF NEEDED,
MAKE OPENING
1/16" - 1/8" WIDER.**

STILL HAVE QUESTIONS?

Tech line hours

Monday - Friday 8Am - 6PM (EST) 812-482-2932

